



Pressurization



Index

General Information	244
Dehydrator Selection Considerations	246
Dehydrator Selection Charts	247

Dehydrators	
Static Desiccator – System Volumes up to 1 ft ³ (28 l)	249
Hand Pump – System Volumes up to 10 ft ³ (283 l)	250
Basic Manual Regenerative Dehydrator – System Volumes up to 10 ft ³ (283 l)	250
Advanced Manual Regenerative Dehydrator – System Volumes up to 10 ft ³ (283 l)	251

MT-Series, DryLine® Automatic Membrane Dehydrators	
Small, MT050 – System Volumes up to 20 ft ³ (560 l)	252
Medium, MT300 – System Volumes 2 ft ³ (57 l) to 80 ft ³ (2264 l)	252
Large, MT600 – System Volumes 50 ft ³ (1415 l) to 150 ft ³ (4245 l)	253
Jumbo MT1700 – System Volumes 110 ft ³ (3113 l) to 410 ft ³ (11320 l)	253

XT-Series, DryLine Programmable Automatic Membrane Dehydrators	
Medium, XT300 – System Volumes 2 ft ³ (57 l) to 80 ft ³ (2264 l)	254
Large, XT600 – System Volumes 50 ft ³ (1415 l) to 150 ft ³ (4245 l)	255
Jumbo XT1700 – System Volumes 110 ft ³ (3113 l) to 410 ft ³ (11320 l)	255
Large Broadcast, XT4500 – System Volumes 100 ft ³ (2832 l) to 2500 ft ³ (70800 l)	256

Distribution Panels	257
--------------------------------------	-----

Gas Distribution Manifolds	257
---	-----

Line Monitors	258
--------------------------------	-----

DryLine MT/XT Series, State-of-the Art, Automatic Regeneration Dehydrators	260
---	-----

Typical Dehydrator System Diagrams	261
---	-----

Pressurization Work Sheet	264
--	-----

Pressurization Accessories	
Low Pressure Components	266
Alarm Monitors	266
Pressure Sensor Switches	267
Pressure Gauges	267
Installation Accessories	267
Fittings	268
Maintenance Components	269

More Information	
Literature	271
Computer Software	271
Dehydrator Repair and Free Loaner Program	271



General Information

Pressurize Your Antenna System for Better Performance and Greater Protection

Maintain System Performance, Save Money

Andrew pressurization equipment can maintain the performance of your premium antenna system components and save you money. A constant supply of dry air under pressure to your transmission lines assures you of high signal quality, low VSWR, and reduced risk of component damage from the effects of moisture.

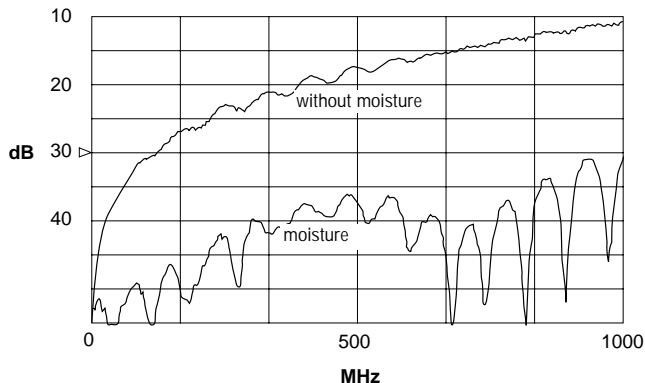

Transmission Line Return Loss with and without moisture.

Operating costs are less because of lower maintenance costs. As a result, lower total costs are realized over the life of your system. You supply a better product for your customers and achieve more market coverage per dollar.

Reduce Risk of Damage, Interruption of Service

Pressurization of your transmission line and antenna system reduces your risk of damage and costly interruption of service. Corrosion caused by accumulated moisture and voltage breakdown (arcing) can be eliminated through positive pressure on the transmission lines.

Over 60 years of Andrew experience and thousands of installations assures you of dependability. Andrew dehydrators are built under high quality standards and each unit is individually tested for eight hours to verify operation. The wide variety of Andrew pressurization equipment available assures you of a dehydrator compatible with your system and design flexibility to meet your future needs.

Minimize Down Time, Protect Revenue

Protection of your revenue stream is important to us because we know that in your business, every minute counts. That's why in the U.S.A. we provide emergency loaner equipment whenever you need it - 24 hours a day, 365 days a year. Our dehydrator alarm options provide sensing of pressure and high humidity and automatic switching of remote units. These alarms quickly alert you to the possible onset of electrical performance degradation so that you can take action.

Simplify Installation, Save Time

Choosing Andrew as a single source for both your pressurization system and antenna system saves you time. There's no need to manage several suppliers. Our wide selection of products, extensive documentation and quick response to your technical questions assure you of proper installation. You'll also save time with our rapid response to price and delivery inquiries and simplified order entry.

Tailored to Your Needs

The Andrew dedicated pressurization R&D department and environmental laboratory can provide you with custom design and manufacturing. When you inquire about special systems requirements, you will receive a quick response. We have a variety of monitoring and alarm feature sets. We'll design, build, and test to satisfy military or other unique requirements.



Moisture in a transmission line can cause corrosion that increases attenuation and reduces system performance.



Burned PTFE shows the conductive path formed by dust-laden moisture. As the path arcs over, the transmission line fails.

World Class Pressurization

Regulations

Andrew dehydrators described in this catalog, except 40525A Series, have been tested and qualified to meet the following worldwide regulatory electrical safety and interference requirements, where applicable, based upon voltage and power frequency.



Conforms to UL 508, Industrial Control Equipment and UL 1995, Refrigeration and AC Compressor Units as tested by ETL Testing Laboratories, Inc., Cortland, New York, a Nationally Recognized Testing Laboratory (NRTL).



Certified to CSA 22, Heating and Cooling Equipment as tested by ETL Testing Laboratories, Inc., Cortland, New York, a Nationally Recognized Testing Laboratory (NRTL).

FCC Class A, Part 15, Sub-part B and DOC Regulations CRC, C.1374



IEC 801-2 Electrostatic Discharge Susceptibility – Immune to ESA from Severity Level 1 (2 kV) through Severity Level 3 (8 kV).

IEC 801-3 Radiated Susceptibility – Electric Field Immune to RFI at 3 V/m from 27 to 500 MHz.

IEC 801-4 Conducted Transients Susceptibility – Immune to conducted line voltage bursts.

EN50082-1 European Community Generic Immunity

CISPR 11 Group 1, Class A EN55011

CISPR 14 (EN55014)

EN60204-1 European Safety

Types of Dry Gas Supply

Pressurization systems can be classified as static or dynamic.

Static Systems: In a non-pressurized system, a breathing static desiccator may be utilized. As the system pressure increases, air is forced out through the desiccator. As pressure decreases, make-up air passes through the desiccator which absorbs the moisture before allowing dry air to enter the system. A static desiccator will last many months on a very small, tight system of 1 ft³ (28 liters) or less.



In a pressurized static system, the transmission line is pressured by an external source such as a hand pump or other means and the source removed. Since the system is not hermetically sealed, it will require frequent inspection for recharging. The gas inlet valve must be readily accessible, and the system operation is very labor intensive.

Dynamic Systems: A dynamic system incorporates a pressurizing source that provides dry gas on demand. The pressurizing source may be nitrogen tanks with a regulator, or an automatic dehydrator. The source is permanently connected to the transmission line system and recharges it to a preset positive pressure as required to compensate for leakage losses. Nitrogen tanks are used for small tight systems where ac power is unavailable. There are no moving parts and they provide a low dewpoint, but the hidden costs of monitoring and tank replacement can be expensive. They are recommended only for systems having low internal and purge volumes. System leaks bleed down tanks rapidly and delivery of nitrogen tanks to site can be undependable.

Manual regenerative dehydrators, which use moisture adsorptive desiccant that can be regenerated by baking in an oven, are also ideal for small, tight systems and are economical. They require small amounts of electrical power and the desiccant must be inspected and regenerated periodically, but they are extremely reliable in operation in many locations and applications.

The newer, fully automatic membrane dehydrators are recommended for low to high system and purge volumes. They are designed to cycle on and off, or run continuously in an emergency, providing a maintenance-free dry air system. Older "pressure swing" automatic dehydrators perform a similar function, but they do not provide the same trouble-free performance, low noise and vibration, and continuous drying capability the membrane units do.

Replace your old or obsolete pressurization system with a state-of-the-art DryLine[®] dehydrator from Andrew.





Dehydrator Selection Considerations

Total System Volume

System Pressure Rating

Availability of Maintenance

Availability of Electric Power

Total System Volume. System volume is determined by adding up the volume of each air dielectric transmission line component for a given installation. For an earth station antenna, the system volume may consist of less than one cubic foot inside the feed and combiner. For a large microwave or broadcast system, it may consist of many cubic feet of air contained in several hundred feet of air dielectric cable or waveguide.

The selected dehydrator must be capable of supplying this volume plus an anticipated leak rate of 1%, and provide sufficient capacity to maintain pressure during a 19°C (35°F) temperature drop in 60 minutes.

These variables have been taken into account in the dehydrator sizing, which can be calculated using the worksheet on pages 264 and 265.

System Pressure Rating. The pressure inside a transmission line system must be maintained at a positive level and below the maximum pressure rating of the components in the system. See "Caution" at the top of calculation page 265.

Availability of Maintenance. Hand pumps, nitrogen, static desiccators and manual regenerative dehydrators are best suited to low volume tight systems at readily accessible sites. However, the monitoring and changing of the desiccator or nitrogen tanks are labor intensive. Remote and unattended sites are best suited for the fully automatic membrane dehydrator, which is virtually maintenance-free. All Andrew dehydrators can be changed out in less than 10 minutes without losing system pressure.

Availability of Electric Power. Dehydrators are available in multiple voltages. The selection must be compatible with the available Mains power, taking into account proper wire size to prevent voltage drop from the building Mains to the dehydrator, and proper Mains circuit breaker size. Dehydrators are available for 115 Vac/60 Hz and 220 Vac/50 Hz operation and for 21 to 68 Vdc operation. Some units operate over wider ac and dc ranges. Detailed descriptions, features and characteristics follow on pages 247 through 256.

Alarm Options and Benefits

Alarms are available to alert you to system status. These contacts are brought to a chassis-mounted terminal strip

(for dehydrators) or to a rear-mounted terminal strip (for XH line monitors). The low pressure alarm on MT-600/1700 is on a cable, instead of at the terminal strip.

Low Pressure Alarm. Standard on all dehydrators. When pressure drops below a set point, dry contacts will close or the switch will operate to signal an alarm to the customer provided system. For the XT series dehydrators, the alarm setting is user programmable; for all other units it is factory set. A low pressure alarm can alert you to a power failure, (the dehydrator is not being activated), waveguide damage by projectiles or a lightning strike (the dehydrator runs, but cannot provide the minimum pressure), or a dehydrator malfunction.

High Pressure Alarm. Option available on XH series line monitors, 40004 pressurization monitors and selected MT050 dehydrators. When pressure increases above a set point, dry contacts operate to signal an alarm. The XH setting is user programmable; the 40004 and MT050 are factory set. Dehydrators typically do not require a high pressure alarm. All except 40525A series include an over-pressure relief valve.

Excessive Run Alarm. Option for most dehydrators. Adjustable by the user to indicate continuous running of the dehydrator. When the unit reaches the preset excess run time, a contact will close or a switch will operate to signal the alarm. The excess run alarm will alert you to system degradation due to failure or vandalism, or a dehydrator that fails to shut off in the normal time. The unit should be preset for a few minutes above the normal dehydrator run time.

High Humidity Alarm. Option for most dehydrators. The alarm is factory set to operate at 7.5% relative humidity. When the dewpoint of the dehydrator reaches the set point, a dry contact switch will operate and signal the alarm.

Power Fail Alarm. A dry contact switch operates when power is removed from the unit or the circuit breaker opens.

Flow Meters

Flow meters, available with the multiple output line monitors, are useful in monitoring a system. Two scales are provided for observation depending on dehydrator output. A black ball measures flow from 0 to 7 ft³/hr (0 to 200 l/hr) and a silver ball from 8 to 28 ft³/hr (225 to 790 l/hr). They are used to check the integrity of the various lines. The red arrow indicator is placed at the location of the ball while the system is being pressurized to establish a base value. A positive deviation from this initial setting is an indication of degradation of that particular line.

Dehydrator Selection Chart – U.S. Customary Units



Pressurization

Model Number	Flow Rate SCFM*	Pressure PSIG*	Dew Point °F	Recom. Volume ft ³	Type**	Desiccant Capacity ft ³	Voltage	Freq. Hz	Power Watts	Alarms Provided*	Operating Temp. °F	Power Cord	Meets Regulatory Requirements of
40525A													
40525A	0.9	3-8	-33	0-10	D	200	115 Vac	60	230	none	32 to 90	US	None
40525A-3	0.9	3-8	-33	0-10	D	200	230 Vac	50	230	none	32 to 90		None
40525A-4	0.9	1-5	-33	0-10	D	200	115 Vac	60	230	none	32 to 90	US	None
40525A-5	0.9	1-5	-33	0-10	D	200	230 Vac	50	230	none	32 to 90		None
MR050													
MR050-31045	0.05	0.3-0.5	-40	0-10	D	200	85-264 Vac	47-400	11	LP	-16 to 104	US	ETL/CETL/CE
MR050-31046	0.05	0.3-0.5	-40	0-10	D	200	85-264 Vac	47-400	11	LP	-16 to 104	Export	ETL/CETL/CE
MR050-31037	0.05	0.3-0.5	-40	0-10	D	200	10-72 Vdc	dc	11	LP	-16 to 104	DC cable	ETL/CETL/CE
MR050-31345	0.05	0.3-0.5	-40	0-10	D	200	85-264 Vac	47-400	11	Full	-16 to 104	US	ETL/CETL/CE
MR050-31346	0.05	0.3-0.5	-40	0-10	D	200	85-264 Vac	47-400	11	Full	-16 to 104	Export	ETL/CETL/CE
MR050-31337	0.05	0.3-0.5	-40	0-10	D	200	10-72 Vdc	dc	11	Full	-16 to 104	DC cable	ETL/CETL/CE
MR050-81045	0.05	3-5	-40	0-10	D	200	85-264 Vac	47-400	11	LP	-16 to 104	US	ETL/CETL/CE
MR050-81046	0.05	3-5	-40	0-10	D	200	85-264 Vac	47-400	11	LP	-16 to 104	Export	ETL/CETL/CE
MR050-81037	0.05	3-5	-40	0-10	D	200	10-72 Vdc	dc	11	LP	-16 to 104	DC cable	ETL/CETL/CE
MR050-81345	0.05	3-5	-40	0-10	D	200	85-264 Vac	47-400	11	Full	-16 to 104	US	ETL/CETL/CE
MR050-81346	0.05	3-5	-40	0-10	D	200	85-264 Vac	47-400	11	Full	-16 to 104	Export	ETL/CETL/CE
MR050-81337	0.05	3-5	-40	0-10	D	200	10-72 Vdc	dc	11	Full	-16 to 104	DC cable	ETL/CETL/CE
MRS050													
MRS050-31045	0.05	0.3-0.5	-40	0-10	D	200	85-264 Vac	47-400	11	LP	-16 to 104	US	CE
MRS050-31046	0.05	0.3-0.5	-40	0-10	D	200	85-264 Vac	47-400	11	LP	-16 to 104	Export	CE
MRS050-31037	0.05	0.3-0.5	-40	0-10	D	200	10-72 Vdc	dc	11	LP	-16 to 104	DC cable	CE
MRS050-31345	0.05	0.3-0.5	-40	0-10	D	200	85-264 Vac	47-400	11	Full	-16 to 104	US	CE
MRS050-31346	0.05	0.3-0.5	-40	0-10	D	200	85-264 Vac	47-400	11	Full	-16 to 104	Export	CE
MRS050-31337	0.05	0.3-0.5	-40	0-10	D	200	10-72 Vdc	dc	11	Full	-16 to 104	DC cable	CE
MRS050-81045	0.05	3-5	-40	0-10	D	200	85-264 Vac	47-400	11	LP	-16 to 104	US	CE
MRS050-81046	0.05	3-5	-40	0-10	D	200	85-264 Vac	47-400	11	LP	-16 to 104	Export	CE
MRS050-81037	0.05	3-5	-40	0-10	D	200	10-72 Vdc	dc	11	LP	-16 to 104	DC cable	CE
MRS050-81345	0.05	3-5	-40	0-10	D	200	85-264 Vac	47-400	11	Full	-16 to 104	US	CE
MRS050-81346	0.05	3-5	-40	0-10	D	200	85-264 Vac	47-400	11	Full	-16 to 104	Export	CE
MRS050-81337	0.05	3-5	-40	0-10	D	200	10-72 Vdc	dc	11	Full	-16 to 104	DC cable	CE
MT050													
MT050-81015	0.05	5	-50	0-20	M	N/A	115 Vac	50/60	184	LP	34 to 104	US	ETL/CETL/CE
MT050-81026	0.05	5	-50	0-20	M	N/A	230 Vac	50/60	184	LP	34 to 104	Export	ETL/CETL/CE
MT050-81037	0.05	5	-50	0-20	M	N/A	21-28/42-68 Vdc	dc	230	LP	34 to 104	None	ETL/CETL/CE
MT050-81315	0.05	5	-50	0-20	M	N/A	115 Vac	50/60	184	Full	34 to 104	US	ETL/CETL/CE
MT050-81326	0.05	5	-50	0-20	M	N/A	230 Vac	50/60	184	Full	34 to 104	Export	ETL/CETL/CE
MT050-81337	0.05	5	-50	0-20	M	N/A	21-28/42-68 Vdc	dc	230	Full	34 to 104	None	ETL/CETL/CE
MT050-81526	0.05	5	-50	0-20	M	N/A	230 Vac	50/60	184	Full+ HP	34 to 104	Export	ETL/CETL/CE
MT300													
MT300-81015	0.3	3-8	-50	2-80	M	N/A	115 Vac	50/60	390	LP	34 to 120	US	ETL/CETL/CE
MT300-81026	0.3	3-8	-50	2-80	M	N/A	230 Vac	50/60	390	LP	34 to 120	Export	ETL/CETL/CE
MT300-82015	0.3	3-8	-50	2-80	M	N/A	115 Vac	50/60	390	LP	34 to 120	US	ETL/CETL/CE
MT300-82026	0.3	3-8	-50	2-80	M	N/A	230 Vac	50/60	390	LP	34 to 120	Export	ETL/CETL/CE
MT300-81315	0.3	3-8	-50	2-80	M	N/A	115 Vac	50/60	390	Full	34 to 120	US	ETL/CETL/CE
MT300-81326	0.3	3-8	-50	2-80	M	N/A	230 Vac	50/60	390	Full	34 to 120	Export	ETL/CETL/CE
MT300-82315	0.3	3-8	-50	2-80	M	N/A	115 Vac	50/60	390	Full	34 to 120	US	ETL/CETL/CE
MT300-82326	0.3	3-8	-50	2-80	M	N/A	230 Vac	50/60	390	Full	34 to 120	Export	ETL/CETL/CE
XT300													
XT300-91015	0.3	P 0.3-15	-50	2-80	M	N/A	115 Vac	50/60	390	Note 1	34 to 120	US	ETL/CETL/CE
XT300-91026	0.3	P 0.3-15	-50	2-80	M	N/A	230 Vac	50/60	390	Note 1	34 to 120	Export	ETL/CETL/CE
XT300-92015	0.3	P 0.3-15	-50	2-80	M	N/A	115 Vac	50/60	390	Note 1	34 to 120	US	ETL/CETL/CE
XT300-92026	0.3	P 0.3-15	-50	2-80	M	N/A	230 Vac	50/60	390	Note 1	34 to 120	Export	ETL/CETL/CE
MT-600													
MT-600-201	0.6	3-8	-50	50-150	M	N/A	115 Vac	50/60	780	LP	34 to 120	US	ETL/CETL/CE
MT-600-202	0.6	3-8	-50	50-150	M	N/A	230 Vac	50/60	720	LP	34 to 120	Export	ETL/CETL/CE
XT-600													
XT-600-201	0.6	P 0.3-15	-50	50-150	M	N/A	115 Vac	50/60	780	Note 1	34 to 120	US	ETL/CETL/CE
XT-600-202	0.6	P 0.3-15	-50	50-150	M	N/A	230 Vac	50/60	720	Note 1	34 to 120	Export	ETL/CETL/CE
MT-1700													
MT-1700-201	1.7	3-8	-50	110-400	M	N/A	115 Vac	50/60	1580	LP	34 to 120	US	ETL/CETL/CE
MT-1700-202	1.7	3-8	-50	110-400	M	N/A	230 Vac	50/60	1430	LP	34 to 120	Export	ETL/CETL/CE
XT-1700													
XT-1700-201	1.7	P 0.3-15	-50	110-400	M	N/A	115 Vac	50/60	1580	Note 1	34 to 120	US	ETL/CETL/CE
XT-1700-202	1.7	P 0.3-15	-50	110-400	M	N/A	230 Vac	50/60	1430	Note 1	34 to 120	Export	ETL/CETL/CE
XT4500													
XT4500-91325	4.5	P 0.3-5	-50	100-2500	M	N/A	230 Vac	50/60	2645	Full	34 to 104	US	ETL/CETL/CE
XT4500-01325	4.5	P 0.3-5	-50	100-2500	M	N/A	230 Vac	50/60	2645	Full	34 to 104	US	ETL/CETL/CE

* SCFM = standard cubic feet per minute at standard altitude (sea level), temperature (70°F) and pressure (14.7 psig). PSIG = gauge pressure in lb/in². P = programmable. LP = low pressure. HP = high pressure.

** M = Membrane DryLine type dehydrator. D = Desiccant type dehydrator requires manual regeneration of desiccant after 200 cubic feet of air is used. LP = Low pressure alarm. Full = Full alarm option includes low pressure, high humidity, power fail and excess run provided on terminal strip.

Note 1: Alarms for XT dehydrators provided by XH monitor (required for all XT series dehydrators, except XT4500).



Dehydrator Selection Chart – International Standard (SI) Units

Model Number	Flow Rate SLPM*	Pressure kPa*	Dew Point °C	Recom. Vol. Liters	Type**	Desiccant Capacity Liters	Voltage	Freq. Hz	Power Watts	Alarms Provided*	Operating Temp. °C	Power Cord	Meets Regulatory Requirements of
40525A													
40525A	25	21-55	-36	0-283	D	5660	115 Vac	60	230	none	0 to 32	US	None
40525A-3	25	21-55	-36	0-283	D	5660	230 Vac	50	230	none	0 to 32		None
40525A-4	25	7-34	-36	0-283	D	5660	115 Vac	60	230	none	0 to 32	US	None
40525A-5	25	7-34	-36	0-283	D	5660	230 Vac	50	230	none	0 to 32		None
MR050													
MR050-31045	1.4	2.1-3.5	-40	0-283	D	5660	85-264 Vac	47-400	11	LP	-10 to 40	US	ETL/CETL/CE
MR050-31046	1.4	2.1-3.5	-40	0-283	D	5660	85-264 Vac	47-400	11	LP	-10 to 40	Export	ETL/CETL/CE
MR050-31037	1.4	2.1-3.5	-40	0-283	D	5660	10-72 Vdc	dc	11	LP	-10 to 40	DC cable	ETL/CETL/CE
MR050-31345	1.4	2.1-3.5	-40	0-283	D	5660	85-264 Vac	47-400	11	Full	-10 to 40	US	ETL/CETL/CE
MR050-31346	1.4	2.1-3.5	-40	0-283	D	5660	85-264 Vac	47-400	11	Full	-10 to 40	Export	ETL/CETL/CE
MR050-31337	1.4	2.1-3.5	-40	0-283	D	5660	10-72 Vdc	dc	11	Full	-10 to 40	DC cable	ETL/CETL/CE
MR050-81045	1.4	21-35	-40	0-283	D	5660	85-264 Vac	47-400	11	LP	-10 to 40	US	ETL/CETL/CE
MR050-81046	1.4	21-35	-40	0-283	D	5660	85-264 Vac	47-400	11	LP	-10 to 40	Export	ETL/CETL/CE
MR050-81037	1.4	21-35	-40	0-283	D	5660	10-72 Vdc	dc	11	LP	-10 to 40	DC cable	ETL/CETL/CE
MR050-81345	1.4	21-35	-40	0-283	D	5660	85-264 Vac	47-400	11	Full	-10 to 40	US	ETL/CETL/CE
MR050-81346	1.4	21-35	-40	0-283	D	5660	85-264 Vac	47-400	11	Full	-10 to 40	Export	ETL/CETL/CE
MR050-81337	1.4	21-35	-40	0-283	D	5660	10-72 Vdc	dc	11	Full	-10 to 40	DC cable	ETL/CETL/CE
MRS050													
MRS050-31045	1.4	2.1-3.5	-40	0-283	D	5660	85-264 Vac	47-400	11	LP	-10 to 40	US	CE
MRS050-31046	1.4	2.1-3.5	-40	0-283	D	5660	85-264 Vac	47-400	11	LP	-10 to 40	Export	CE
MRS050-31037	1.4	2.1-3.5	-40	0-283	D	5660	10-72 Vdc	dc	11	LP	-10 to 40	DC cable	CE
MRS050-31345	1.4	2.1-3.5	-40	0-283	D	5660	85-264 Vac	47-400	11	Full	-10 to 40	US	CE
MRS050-31346	1.4	2.1-3.5	-40	0-283	D	5660	85-264 Vac	47-400	11	Full	-10 to 40	Export	CE
MRS050-31337	1.4	2.1-3.5	-40	0-283	D	5660	10-72 Vdc	dc	11	Full	-10 to 40	DC cable	CE
MRS050-81045	1.4	21-35	-40	0-283	D	5660	85-264 Vac	47-400	11	LP	-10 to 40	US	CE
MRS050-81046	1.4	21-35	-40	0-283	D	5660	85-264 Vac	47-400	11	LP	-10 to 40	Export	CE
MRS050-81037	1.4	21-35	-40	0-283	D	5660	10-72 Vdc	dc	11	LP	-10 to 40	DC cable	CE
MRS050-81345	1.4	21-35	-40	0-283	D	5660	85-264 Vac	47-400	11	Full	-10 to 40	US	CE
MRS050-81346	1.4	21-35	-40	0-283	D	5660	85-264 Vac	47-400	11	Full	-10 to 40	Export	CE
MRS050-81337	1.4	21-35	-40	0-283	D	5660	10-72 Vdc	dc	11	Full	-10 to 40	DC cable	CE
MT050													
MT050-81015	1.4	35	-45	0-566	M	N/A	115 Vac	50/60	184	LP	1 to 40	US	ETL/CETL/CE
MT050-81026	1.4	35	-45	0-566	M	N/A	230 Vac	50/60	184	LP	1 to 40	Export	ETL/CETL/CE
MT050-81037	1.4	35	-45	0-566	M	N/A	21-28/42-68 Vdc	dc	230	LP	1 to 40	None	ETL/CETL/CE
MT050-81315	1.4	35	-45	0-566	M	N/A	115 Vac	50/60	184	Full	1 to 40	US	ETL/CETL/CE
MT050-81326	1.4	35	-45	0-566	M	N/A	230 Vac	50/60	184	Full	1 to 40	Export	ETL/CETL/CE
MT050-81337	1.4	35	-45	0-566	M	N/A	21-28/42-68 Vdc	dc	230	Full	1 to 40	None	ETL/CETL/CE
MT050-81526	1.4	35	-45	0-566	M	N/A	230 Vac	50/60	184	Full+ HP	1 to 40	Export	ETL/CETL/CE
MT300													
MT300-81015	8.5	21-55	-45	56-2264	M	N/A	115 Vac	50/60	390	LP	1 to 49	US	ETL/CETL/CE
MT300-81026	8.5	21-55	-45	56-2264	M	N/A	230 Vac	50/60	390	LP	1 to 49	Export	ETL/CETL/CE
MT300-82015	8.5	21-55	-45	56-2264	M	N/A	115 Vac	50/60	390	LP	1 to 49	US	ETL/CETL/CE
MT300-82026	8.5	21-55	-45	56-2264	M	N/A	230 Vac	50/60	390	LP	1 to 49	Export	ETL/CETL/CE
MT300-81315	8.5	21-55	-45	56-2264	M	N/A	115 Vac	50/60	390	Full	1 to 49	US	ETL/CETL/CE
MT300-81326	8.5	21-55	-45	56-2264	M	N/A	230 Vac	50/60	390	Full	1 to 49	Export	ETL/CETL/CE
MT300-82315	8.5	21-55	-45	56-2264	M	N/A	115 Vac	50/60	390	Full	1 to 49	US	ETL/CETL/CE
MT300-82326	8.5	21-55	-45	56-2264	M	N/A	230 Vac	50/60	390	Full	1 to 49	Export	ETL/CETL/CE
XT300													
XT300-91015	8.5	P 2-105	-45	56-2264	M	N/A	115 Vac	50/60	390	Note 1	1 to 49	US	ETL/CETL/CE
XT300-91026	8.5	P 2-105	-45	56-2264	M	N/A	230 Vac	50/60	390	Note 1	1 to 49	Export	ETL/CETL/CE
XT300-92015	8.5	P 2-105	-45	56-2264	M	N/A	115 Vac	50/60	390	Note 1	1 to 49	US	ETL/CETL/CE
XT300-92026	8.5	P 2-105	-45	56-2264	M	N/A	230 Vac	50/60	390	Note 1	1 to 49	Export	ETL/CETL/CE
MT-600													
MT-600-201	17	21-55	-45	1415-4245	M	N/A	115 Vac	50/60	780	LP	1 to 49	US	ETL/CETL/CE
MT-600-202	17	21-55	-45	1415-4245	M	N/A	230 Vac	50/60	72	LP	1 to 49	Export	ETL/CETL/CE
XT-600													
XT-600-201	17	P 2-105	-45	1415-4245	M	N/A	115 Vac	50/60	780	Note 1	1 to 49	US	ETL/CETL/CE
XT-600-202	17	P 2-105	-45	1415-4245	M	N/A	230 Vac	50/60	72	Note 1	1 to 49	Export	ETL/CETL/CE
MT-1700													
MT-1700-201	48	21-55	-45	3113-11320	M	N/A	115 Vac	50/60	1580	LP	1 to 49	US	ETL/CETL/CE
MT-1700-202	48	21-55	-45	3113-11320	M	N/A	230 Vac	50/60	1430	LP	1 to 49	Export	ETL/CETL/CE
XT-1700													
XT-1700-201	48	P 2-105	-45	3113-11320	M	N/A	115 Vac	50/60	1580	Note 1	1 to 49	US	ETL/CETL/CE
XT-1700-202	48	P 2-105	-45	3113-11320	M	N/A	230 Vac	50/60	1430	Note 1	1 to 49	Export	ETL/CETL/CE
XT4500													
XT4500-91325	127	P 2-105	-45	2830-70750	M	N/A	230 Vac	50/60	2645	Full	1 to 40	US	ETL/CETL/CE
XT4500-01325	127	P 2-105	-45	2830-70750	M	N/A	230 Vac	50/60	2645	Full	1 to 40	US	ETL/CETL/CE

* SLPM = standard liters per minute at standard altitude (sea level), temperature (21°C) and pressure (101 kPa). kPa = gauge pressure in kilopascals.

P = programmable. LP = low pressure. HP = high pressure.

** M = Membrane DryLine type dehydrator. D = Desiccant type dehydrator requires manual regeneration of desiccant after 5660 cubic liters of air is used. LP = Low pressure alarm. Full = Full alarm option includes low pressure, high humidity, power fail and excess run provided on terminal strip.

Note 1: Alarms for XT dehydrators provided by XH monitor (required for all XT series dehydrators, except XT4500).

SD-001/SD-002A Static Desiccators



Static desiccators are compact and economical, disposable devices which eliminate moisture in very small transmission lines and antenna feeds. The units have no moving parts and no electrical connections, yet they are capable of providing many months of protection.

Typical service life, of an SD-001, in a very small system of 0.1-ft³ (2.8 liters) volume, experiencing a temperature change of 22° C (40° F) per day, at 40% RH, is one year.

Similarly, the service life of an SD-002A in a larger system having 1-ft³ volume and experiencing a temperature change of 10°C (30°F) per day, at 40% RH, is also one year.

System volumes up to 0.1 ft³ (2.8 liters)



SD-001 Static Desiccator for Small Systems

Applications – A single unit is recommended for small feeds and very small and short waveguide runs having internal volumes of less than 0.1 ft³. This unit is ideal for antenna feeds that are fed by foam-dielectric cable where conventional pressurization is not possible. The SD-001 mounts directly to the feed's 1/8" NPT female pressure fitting.

SD-001 Static Desiccator Characteristics

Dimensions	4.75 in (121 mm) long by 1.0 in (25 mm) diameter
Net Weight	0.2 lb (0.09 kg)
Temperature Range	-50°C (-58°F) to +50°C (122°F)
Interface	1/8" NPT male threads

Static desiccators mount directly to any convenient pressure inlet having a 1/8" NPT female fitting. Mount them in a location that is easily accessible for viewing and replacement.

The clear plastic body of the SD-001 and the translucent polyethylene container of the SD-002A allow visual inspection of the indicating desiccant as the color turns from blue to pink/white and the material becomes exhausted.

When the desiccant has changed to the pink/white color in 80% of the viewing area, the unit should be replaced.

System volumes up to 1 ft³ (28 liters)



SD-002A Static Desiccator

Applications – In general, one unit is recommended for feed and combiners having less than 1 ft³ (28 l) volume. If a 1/8" NPT fitting is not available, use a pressure inlet (Pressure inlets are not included with the static desiccator.)

Microwave Applications – Ideal for rooftop applications at any frequency with waveguide up to 10 ft (3 m) in length.

ESA Applications – Typical applications are shown on page 263. The recommendations are for antennas without air dielectric feeder systems (for example, connected using foam dielectric cable or having radio equipment mounted inside the antenna hub). Actual requirements should be based on total system volume, but most ESA antennas can be covered with one SD-002A.

Note: If the volume consists of a long run of waveguide (in excess of 10 ft), a dehydrator is recommended.

SD-002A Static Desiccator Characteristics

Dimensions	4 in (102 mm) long, excluding the 1/8" NPT fitting by 2 in (51 mm) diameter
Net Weight	0.4 lb (0.18 kg)
Temperature Range	-50°C (-58°F) to +50°C (122°F)
Interface	1/8" NPT male threads

Note: the SD-002A is not recommended for applications where there is direct exposure to sunlight. Use an SD-001 or a dehydrator instead.

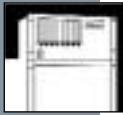

860G Hand Pump

System Volumes up to 10 ft³ (283 liters)



Hand pumps are lightweight portable air drying systems capable of pressurizing up to 30 lb/in² (210 kPa). Removal of moisture is accomplished by passing ambient air through a cylinder of color indicating silica gel desiccant. The pump contains a sight glass to view the moisture condition of the desiccant. When the dark blue color changes to amber, it is time to replace or regenerate the desiccant. Do not use the pump after the desiccant turns amber.

The desiccant may be regenerated by baking in an oven at 177°C (350°F) for approximately four hours until it returns to a dark blue color. Allow to cool in a sealed container before returning it to the pump.

Initial system purging is recommended. It takes 80 strokes to purge a 1 ft³ volume with one air change. To pressurize the same volume, it requires 5.5 strokes per 1.0 lb/in².

Applications – Hand pumps are suitable for use in pressurizing any small, tight, electromechanical apparatus requiring dry air to protect against the ingress of moisture, and can supply approximately 135 ft³ (3857 liters) of dry air under ambient conditions of 40% relative humidity and 21°C (70°F) before regeneration is required.

Each pump comes with a 7 ft (2 m) hose to easily reach a gas inlet valve. If the system does not contain a pressure gauge, the Model 860G hand pump contains a 0-30 lb/in² (207 kPa) gauge and fittings.

860G Hand Pump Characteristics

Dimensions	8 in (203 mm) base, 2.5 in (64 mm) diameter housing, 26 in (660 mm) total height
Net Weight	9.0 lb (4.1 kg)
Temperature range	-15°C to +50°C (5°F to 122°F)
Hose Length	7 feet (2.1 m)
Interface	gas inlet valve

40525A Basic Manual Regenerative Dehydrator

System Volumes up to 10 ft³ (283 liters)



Manual regenerative dehydrators provide an economical automatic drying system. “Automatic” for the 40525A is defined as automatically responding to the pressure requirements of the system, not automatic regeneration of the desiccant. The color indicating desiccant is easily viewed through the canister attached to the unit, providing for programmed replacement. You can replace the desiccant with new desiccant or you can regenerate it.

To regenerate the desiccant, remove it from the canister and bake it in an oven at 177°C (350°F) for approximately four hours, until it returns to a dark blue color. Allow it to cool in a sealed container. Then return the desiccant to the canister. These dehydrators can supply 200 ft³ (5665 liters) of -40°C (-40°F) dewpoint air under the ambient conditions of 40% RH and 21°C (70°F) before regeneration is needed. They are quiet, vibration-free and come in low and high pressure versions, as well as various voltages.

Applications – The 40525 series dehydrators are ideal where economy is the greatest consideration. These units contain a compressor, pressure switch and a desiccant container. The output is provided with a shut off valve to allow a desiccant change without a system pressure loss.

They are available in ac versions only and are equipped with a 10 ft (3 m) long power cable with a U.S.A. plug which can be replaced with a proper in-country plug.

Each dehydrator comes supplied with a single line installation kit consisting of 25 ft (7 m) of 3/8" poly tubing and a 1/8" NPT to 3/8" poly tube connector and a 1/8" NPT street elbow.

40525A Dehydrator Characteristics

Dimensions	12 x 15.75 x 5 in (305 x 401 x 127 mm)
Net Weight	21 lb (9.5 kg)



MR050/MRS050 Series

Advanced Manual Regenerative Dehydrators

Manual regenerative dehydrators provide an economical automatic drying system. "Automatic" for the MR050 and MRS050 series is defined as automatically responding to the pressure requirements of the system, not automatic regeneration of the desiccant.

The color indicating desiccant is easily viewed through the canister attached to the unit, providing for programmed replacement. You can replace the desiccant with new desiccant or you can regenerate it.

To regenerate the desiccant, remove it from the canister and bake it in an oven at 177°C (350°F) for approximately four hours, until it returns to a dark blue color.

Allow it to cool in a sealed container. Then return the desiccant to the canister.

These dehydrators can supply 200 ft³ (2800 liters) of -40°C (-40°F) dewpoint air under ambient conditions of 40% RH and 21°C (70°F) before regeneration is required. Capacity can be doubled by adding a second desiccant canister in the airpath. They are quiet, vibration-free and come in low and high pressure versions, as well as various voltages.

Each dehydrator comes supplied with a single line installation kit consisting of 25 ft (7 m) of 3/8" poly tubing and a 1/8" NPT to 3/8" poly tube connector and a 1/8" NPT street elbow.

System volumes up to 10 ft³ (283 liters)



The MR050 series dehydrators are designed to meet the North American and new European N-3 Standards for complete front access for installation and maintenance. The desiccant container and associated connections are readily accessible from the front of the unit. Front mounted controls and status indicators provide system pressure, visual (desiccant color) indication, illuminated on/off switch, circuit breaker and the system shut off valve. Each dehydrator contains a low pressure alarm with Form C dry contacts on a terminal strip for connection to an alarm system. High humidity, excess run, and power fail alarms are provided in a single, add-in alarm option. The MR050 may be rack mounted, wall mounted or self supported and is available in ac and dc versions.

The 220 Vac unit includes IEC power connectors and an International harmonized, 10 ft (3 m) long power cable with stripped leads for installation of a proper in-country plug. The 115 Vac version is equipped with a standard UL/CSA cord and plug. DC units include a dc power connector and a 10 ft (3 m) wired power cable with stripped leads.

MR050 Dehydrator Characteristics

Dimensions	7 x 19 x 8.6 in (178 x 483 x 218 mm)
Net Weight	26 lb (11.8 kg)

For more information

F A X
Bulletin
1 8 4 6
See page 1

System volumes up to 10 ft³ (283 liters)



The MRS050 series dehydrators are especially designed to meet the European 7R Standards for mounting in slimline racks, providing complete front access for installation and maintenance. The desiccant container and connections are readily accessible from the front of the unit. Front mounted controls and status indicators provide system pressure, visual humidity indication, illuminated on/off switch, circuit breaker and the system shut off valve. Each dehydrator contains a low pressure alarm with Form C dry contacts on a terminal strip for connection to an alarm system. High humidity, excess run, and power fail alarms are provided in a single, add-in alarm option. The MRS050 may be rack mounted or wall mounted and is available in ac and dc versions.

The ac unit includes IEC power connectors and an International harmonized, 10 ft (3 m) long power cable with stripped leads for installation of a proper in-country plug for 220 Vac units and a UL/CSA cord and plug for 115 Vac units. DC units include a dc power connector and a 10 ft (3 m) wired power cable with stripped leads.

MRS050 Dehydrator Characteristics

Dimensions	17.6 x 4.5 x 8.5 in (447 x 115 x 216 mm)
Net Weight	17 lb (7.7 kg)

For more information

F A X
Bulletin
3 5 5 1
See page 1

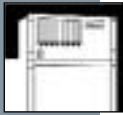

MT050 DryLine® Small Automatic Membrane Dehydrator

System Volumes up to 20 ft³ (560 liters)



This small compact fully automatic membrane dehydrator is ideal for earth station, small microwave and cellular systems from 0.1 to 20 ft³ (560 liters) in volume. It requires only 4 RUs, 7 in (178 mm) of space in a 19-inch rack and meets the new European N-3 standards for complete front access for installation and routine maintenance.

The **MT050 series** are fixed pressure units, factory set at 5 lb/in² (35 kPa). They also include as standard a built in pressure storage tank, low pressure alarm, pressure gauge, lighted On/Off switch and resettable circuit breaker. High humidity, excess run, and power fail alarms are provided in a single, add-in alarm option.

North American domestic 115 V, 60 Hz units are shipped with a UL/CSA approved power cable and plug. International 230 V, 50 Hz units are shipped with an international harmonized power cable with stripped leads for application of in-country Mains plug. DC units require direct wiring from a terminal strip to the user's dc source. All ac cables connect to the dehydrator with a captivated IEC plug.

All MT050s contain a single line installation kit consisting of 25 ft (7 m) of 3/8" poly tubing, a shut-off valve and 1/8" NPT to 3/8" polyethylene tubing connector and a 1/8" NPT street elbow.

Low pressure operation is possible through the addition of a wall-mount regulator. Pressure of 0.4 lb/in² (fixed) or 1 to 5 lb/in² (user adjustable) are available. See page 266.

The MT050 is designed for rack mount or free standing operation. A wall mount shelf is available separately, see page 266.

MT050 Dehydrator Characteristics

Dimensions (ac units)	7.25 x 19 x 14 in (182 x 475 x 356 mm)
Dimensions (dc unit)	7.25 x 19 x 18.25 in (182 x 475 x 464 mm)
Net Weight (ac units)	42 lb (19 kg)
Net Weight (dc units)	47 lb (21 kg)

MT300 DryLine® Medium Automatic Membrane Dehydrator

*System Volumes from 2 ft³ (57 liters)
to 80 ft³ (2264 liters)*



The **MT300 series** automatic membrane dehydrators are equipped with the unique Andrew uni-mount system allowing for rack, wall or free-standing mounting without additional parts. They are designed to supply dry air at a dewpoint of -45°C (-50°F), or better, under the ambient conditions of 95% RH at 49°C (120°F).

Each MT300 dehydrator contains a low pressure alarm with Form C dry contacts (see page 246) for connection to an alarm system. The MT300 is also available in a sound deadened version. MT300 series are factory set to come on at 3 lb/in² (21 kPa) and to turn off at 8 lb/in² (55 kPa).

An alarm option adds excess run, high humidity, and power fail alarms to the MT300. Units at 115 Vac are shipped with a UL/CSA power cord and plug. 230 Vac units have a harmonized power cable with stripped leads.

All MT300 dehydrators are supplied with a single line installation kit consisting of 25 ft (7 m) of 3/8" poly tube, a shut-off valve and a 1/8" NPT to 3/8" polyethylene connector and a 1/8" NPT street elbow.

Front covers are supplied only on sound deadened units.

Applications – The MT300 series dehydrators are for medium volume microwave, cellular and broadcast systems.

MT300 Dehydrator Characteristics

Dimensions	12.2 x 16.8 x 10.25 in (310 x 428 x 260 mm)
Net Weight	46 lb (21 kg)

For more information

F A X
Bulletin
3 5 5 0
See page 1

For more information

F A X
Bulletin
1 6 6 0
See page 1

MT-600 DryLine®
Large Automatic Membrane Dehydrator

*System Volumes from 50 ft³ (1415 liters)
to 150 ft³ (4245 liters)*



The MT-600 series automatic membrane dehydrators are designed to provide the same features and benefits to large microwave and broadcast applications as the smaller MT300. They are equipped with the unique Andrew uni-mount system allowing for rack, wall or free-standing mounting without additional parts and are designed to supply dry air at a dewpoint of -45°C (-50°F), or better, under the ambient conditions of 95% RH at 49°C (120°F).

Each MT-600 dehydrator contains a low pressure alarm with Form C dry contacts (see page 246) for connection to an alarm system. The MT-600 is also available in a sound deadened version. MT-600 series are factory set to come on at 3 lb/in² (21 kPa) and to turn off at 8 lb/in² (55 kPa).

Units at 115 Vac are shipped with a UL/CSA power cord and plug. 230 Vac units have a harmonized power cable with stripped leads.

All dehydrators contain a single line installation kit consisting of 25 ft (7 m) of 3/8" poly tube, a shut-off valve and a 1/8" NPT to 3/8" polyethylene connector and a 1/8" NPT street elbow.

Front covers are supplied only on sound deadened units.

Applications – The MT600 series dehydrators are for large volume microwave, cellular and broadcast systems, where lengthy and large diameter transmission lines are used.

MT-600 Dehydrator Characteristics

Dimensions	15.7 x 16.8 x 13.5 in (399 x 428 x 343 mm)
Net Weight	68 lb (31 kg)

For more information

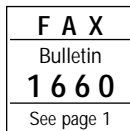

MT-1700 DryLine®
Jumbo Automatic Membrane Dehydrator

*System Volumes from 110 ft³ (3113 liters)
to 410 ft³ (11320 liters)*



The MT-1700 series automatic membrane dehydrators are the largest rack-mountable units offered by Andrew. They are equipped with the unique Andrew uni-mount system allowing for rack, or free-standing mounting without additional parts. They are designed to supply dry air at a dewpoint of -45°C (-50°F), or better, under the ambient conditions of 95% RH at 49°C (120°F).

Each MT-1700 dehydrator contains a low pressure alarm with Form C dry contacts (see page 246) for connection to an alarm system. The MT-1700 is only available in a sound deadened version. MT-1700 series are factory set to come on at 3 lb/in² (21 kPa) and to turn off at 8 lb/in² (55 kPa).

Units at 115 Vac are shipped with a UL/CSA power cord and plug. 230 Vac units have a harmonized power cable with stripped leads.

All dehydrators contain a single line installation kit consisting of 25 ft (7 m) of 3/8" poly tube, a shut-off valve and a 1/8" NPT to 3/8" polyethylene connector and a 1/8" NPT street elbow.

Front covers are supplied on all MT-1700 units.

Applications – The MT-1700 series dehydrators are intended for large volume microwave and broadcast systems.

MT-1700 Dehydrator Characteristics

Dimensions	15.7 x 16.8 x 22 in (399 x 428 x 559 mm)
Net Weight	116 lb (53 kg)

For more information

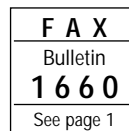

Pressurization

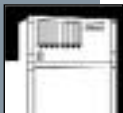

XT-Series DryLine[®] Programmable Automatic Membrane Dehydrators



The **XT-series** programmable automatic membrane dehydrators bring a new level of sophistication and convenience to the supply of pressurized dry air. The dehydrator units are designed for microprocessor control and all operations are fully programmable. With the exception of the XT-4500, the microprocessor is contained in a separate line monitor, which may be separated from the dehydrator unit by up to 100 ft, for convenience in station layout. Extension control cables are offered in 50-ft and 100-ft lengths and are offered separately, see page 267.

The photograph above shows an XT-Dehydrator with an XH-4 Line Monitor mounted above. Line monitors are covered on page 259, where the various options are described in greater detail. Basic features offered by programmability are:

- Compressor ON/OFF, 0.3 - 15 lb/in² (2.1 - 105 kPa)
- Remote sense line for compressor control (recommended be used on 2 separate gas inlet ports)
- Covers most requirements for a low pressure tank and regulator
- Programmable low pressure alarm, starting at 0.1 lb/in² (0.7 kPa)
- Programmable high pressure alarm
- Programmable excess run alarm (0-99 minutes)
- High humidity alarm fixed at 7.5% RH
- LCD display for all functions
- Four languages; French, German, Spanish and English
- Readout in imperial or metric units
- Lightning surge protection

The programmable function can also be used to control two dehydrators in a redundant configuration, where one unit serves as a master and the second operates as a slave. The units alternate in supplying air to the transmission line, but in an emergency, such as a breach in the line, both units will come on to maintain pressure by doubling output airflow.

XT300 DryLine[®] Medium Programmable Automatic Membrane Dehydrators

*System Volumes from 2 ft³ (57 liters) to
80 ft³ (2264 liters)*



The **XT300 series** programmable automatic membrane dehydrators are equipped with the unique Andrew uni-mount system allowing for rack, wall or free-standing mounting without additional parts. They are designed to supply dry air at a dewpoint in excess of -45°C (-50°F) under the ambient conditions of 95% RH at 49°C (120°F).

Each XT300 dehydrator operates under the control of a microprocessor contained in a companion XH-1, XH-4 or XH-8 line monitor (see page 259) and requires the line monitor to function. The XT300 series is designed to program between 0.3 lb/in² (2.1 kPa) and 15 lb/in² (55 kPa). The XT300 is also available in a sound deadened version.

Units at 115 Vac are shipped with a UL/CSA power cord and plug. 230 Vac units have a harmonized power cable with stripped leads.

All dehydrators contain a single line installation kit consisting of 25 ft (7 m) of 3/8" poly tube, a shut-off valve and a 1/8" NPT to 3/8" polyethylene connector and a 1/8" NPT street elbow.

Front covers are supplied only on sound deadened units.

Applications – The XT300 series dehydrators are for medium volume microwave, cellular and broadcast systems.

XT300 Dehydrator Characteristics

Dimensions	12.2 x 16.8 x 10.25 in (310 x 428 x 260 mm)
Net Weight	46 lb (21 kg)

For more
information

F A X
Bulletin
1 6 6 0
See page 1

XT-600 DryLine® Large Programmable Automatic Membrane Dehydrators

*System Volumes from 50 ft³ (1415 liters) to
150 ft³ (4245 liters)*



The XT-600 series programmable automatic membrane dehydrators are designed to provide the same features and benefits to large microwave and broadcast applications as the smaller XT300. They are equipped with the unique Andrew uni-mount system allowing for rack, wall or free-standing mounting without additional parts and are designed to supply dry air at a dewpoint better than -45°C (-50°F) under the ambient conditions of 95% RH at 49°C (120°F).

Each XT-600 dehydrator operates under the control of a microprocessor contained in a companion XH-1, XH-4 or XH-8 line monitor (see page 259) and requires the line monitor to function. The XT-600 series is designed to program between 0.3 lb/in² (21 kPa) and 15 lb/in² (55 kPa). The XT-600 is also available in a sound deadened version.

Units at 115 Vac are shipped with a UL/CSA power cord and plug. 230 Vac units have a harmonized power cable with stripped leads.

All dehydrators contain a single line installation kit consisting of 25 ft (7 m) of 3/8" poly tube, a shut-off valve and a 1/8" NPT to 3/8" polyethylene connector and a 1/8" NPT street elbow.

Front covers are supplied only on sound deadened units.

Applications – The XT-600 series dehydrators are for large volume microwave, cellular and broadcast systems, where lengthy and large diameter transmission lines are used.

XT600 Dehydrator Characteristics

Dimensions	15.7 x 16.8 x 13.5 in (399 x 428 x 343 mm)
Net Weight	68 lb (31 kg)

XT-1700 DryLine® Jumbo Programmable Automatic Membrane Dehydrators

*System Volumes from 110 ft³ (3113 liters)
to 410 ft³ (11320 liters)*



The XT-1700 series automatic membrane dehydrators are the largest rack-mountable units offered by Andrew. They are equipped with the unique Andrew uni-mount system allowing for rack, or free-standing mounting without additional parts. They are designed to supply dry air at a dewpoint better than -45°C (-50°F) under the ambient conditions of 95% RH at 49°C (120°F).

Each XT-1700 dehydrator operates under the control of a microprocessor contained in a companion XH-1, XH-4 or XH-8 line monitor (see page 259) and requires the Line Monitor to function. The XT-1700 series is designed to program between 0.3 lb/in² (2.1 kPa) and 15 lb/in² (55 kPa). The XT-1700 is only available in the sound deadened version.

Units at 115 Vac are shipped with a UL/CSA power cord and plug. 230 Vac units have a harmonized power cable with stripped leads.

All dehydrators contain a single line installation kit consisting of 25 ft (7 m) of 3/8" poly tube, a shut-off valve and a 1/8" NPT to 3/8" polyethylene connector and a 1/8" NPT street elbow.

Front covers are supplied on all XT-1700 units.

Applications – The XT-1700 series dehydrators are intended for large volume microwave and broadcast systems.

XT-1700 Dehydrator Characteristics

Dimensions	15.7 x 16.8 x 22 in (399 x 428 x 559 mm)
Net Weight	116 lb (53 kg)

For more
information

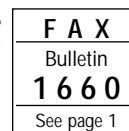

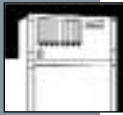

XT4500 DryLine® Large Broadcast Programmable Automatic Membrane Dehydrators

*System Volumes from 100 ft³ (2832 liters)
to 2500 ft³ (70800 liters)*



The XT4500 is our newest addition to the world-class line of DryLine pressurization equipment. This fully automatic membrane dehydrator is designed specifically for broadcast systems with large volumes. It is perfect for remote sites and minimizes the maintenance associated with nitrogen tanks.

XT4500 units have an adjustable output pressure from 0.3 to 5 lb/in² (2.1 to 34 kPa). Other basic features include full alarms, a pressure indicator, a lighted on/off switch, a resettable breaker, and a run-time meter. The unit includes alarms for low pressure, high pressure, high humidity, excess run, and power fail. An over pressure valve protects the system from high pressure.

The XT4500 unit operates at 230 Vac, 50/60 Hz.

A single line installation kit with all materials required for a typical installation comes with each XT4500 dehydrator, including a remote sense and air feed tubing

The XT4500 produces a dew point better than -45° C (-50° F). Pressurized air is forced through its patented membrane drying cartridge where moisture is separated from the system and vented to the outside, eliminating the 60-plus parts associated with pressure swing or heat regenerative dehydrators.

It's Automatic – The XT4500 dehydrator uses remote sensing of system pressure to activate and deactivate the compressor. The dehydrator operates only when needed, reducing wear and the need for maintenance. This feature allows precise control of system pressure.

For more
information

F A X
Bulletin
1 0 2 3 2
See page 1

Stand-Alone Unit – The DryLine XT4500 is designed as a stand-alone unit that can be placed directly against the wall or in a corner.

Easy Access – The power, air, and alarm connections of the XT4500 are readily accessible from the top of the unit.

Front-Mounted Controls and Status Indicators

- Keyboard for setting adjustable parameters
- Pressure indicator that registers both metric and imperial units
- Illuminated power on/off switch
- Compressor run-time meter

Standard Alarms the DryLine XT4500 includes:

- Low pressure alarm adjustable from 0.1 to 3 lb/in² (0.7 to 21 kPa)
- High pressure alarm adjustable from 3 to 6 lb/in² (21 to 42 kPa)
- High humidity alarm (>7.5% RH)
- Excess run alarm adjustable to 255 minutes
- Power fail alarm

Terminal blocks are provided for the alarm outputs.

Electrical Connections – Units designed for use in the U.S.A. operate at 230 Vac, 50/60 Hz and are shipped with UL/CSA approved power cable that uses a U.S.A. plug.

Redundant Dehydrator Options – Master and slave units are available to configure hot standby redundant systems. This option is used for extremely large volume systems, or systems where backup redundancy is required.

Multipressure Applications – With the XT4500, for multiple low pressure applications, a wall mounted low pressure regulator can be added to the system by using an external tank or a large waveguide run as a supply of dry air at a higher pressure.

Fixed regulator, 0.4 lb/in² (2.8 kPa)

.....Type No. **42996A**

Adjustable regulator, 1 to 5 lb/in² (7 to 34 kPa)

.....Type No. **AE01A-D1339-001**

Multiline Applications – When other waveguide or cables need to be pressurized, any of the standard distribution devices may be added to the system. By using the primary waveguide as an air source, any combination of distribution panels, manifolds, or MH type line monitors may be used to distribute the dry air to other equipment.

XT4500 Dehydrator Characteristics

Dimensions	45.25 x 16.5 x 17.5 in (1150 x 420 x 445 mm)
Net Weight	130 lb (59 kg)



DP-4A Distribution Panel

Multiport Manifold for MR- and MT- Series Dehydrators



DP-4A-001 Four-Port Rack-Mount Distribution Panel

Type **DP-4A-001** is a compact and economical distribution panel that provides four output ports. The unit is equipped with a shut-off valve per port. The unit is designed to mount in a standard 19" equipment rack or directly on top of an MR050 or MT-Series dehydrator.

It may be used with any dehydrator except the DryLine® XT-series and comes with a complete four-port installation kit consisting of 100 ft (30.5 m) of 3/8" polyethylene tubing, four tubing mounting racks, 24 nylon ties, four 1/8" NPT to 3/8" tubing male connectors, four 1/8" NPT street elbows, four 3/8" connector sleeves, one roll Teflon† tape, eight plastic inserts and one 3/8" tubing tee.

Panels can be connected together to provide additional outputs above four.

† Teflon® is a registered trademark of E.I. du Pont de Nemours & Co., Inc.

6600-Series Gas Distribution Manifolds

Multiport Manifolds with Gauges for MR and MT Series Dehydrators

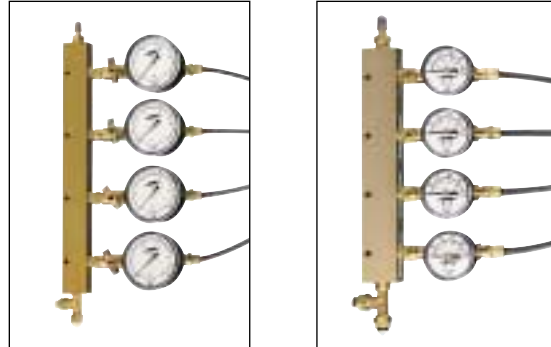

6600-Series Manifolds

The **6600-series** manifolds are compact economical manifolds that provide up to six outlet ports. The units are equipped with shut-off valves and pressure gauges. Two or more may be combined using the included hex nipple.

6600D-series can be used with any dehydrator.

L6600D-series are limited to use with low pressure dehydrators which do not exceed 5 lb/in² (35 kPa).

Includes installation accessories, 25 feet (7.6m) of 3/8" polyethylene tubing, 1/8" NPT to 3/8" tubing male connector, 1/8" NPT street elbow and compression sleeve per line. Also, 24 nylon ties, 4 tubing mounting racks and one roll of Teflon† tape are supplied.

6600D Manifold – Features a dual scale pressure gauge 0-15 lb/in² (0-100 kPa)

- Two portsType **6600D-2**
- Four portsType **6600D-4**
- Six portsType **6600D-6**

L6600D Manifold – Features a dual scale pressure gauge 0-5 lb/in² (0-35 kPa)

- Two portsType **L6600D-2**
- Four portsType **L6600D-4**

6600-Series Gas Distribution Manifolds

Model Number	6600D-2	6600D-4	6600D-6	L6600D-2	L6600D-4
Number of Ports	2	4	6	2	4
Dimensions, in (mm)	6.8 x 4.6 x 2.25 (173 x 117 x 57)	10.8 x 4.6 x 2.25 (274 x 117 x 57)	14.8 x 4.6 x 2.25 (376 x 117 x 57)	8.8 x 6.9 x 3 (224 x 175 x 76)	14.8 x 6.9 x 3 (376 x 175 x 76)
Net Weight, lb (kg)	2 (0.9)	4 (1.8)	6 (2.7)	5 (2.3)	7 (3.2)

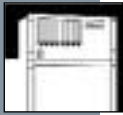

ML/MH Line Monitors

Multiport Gas Distribution Monitors for MT Series Dehydrators

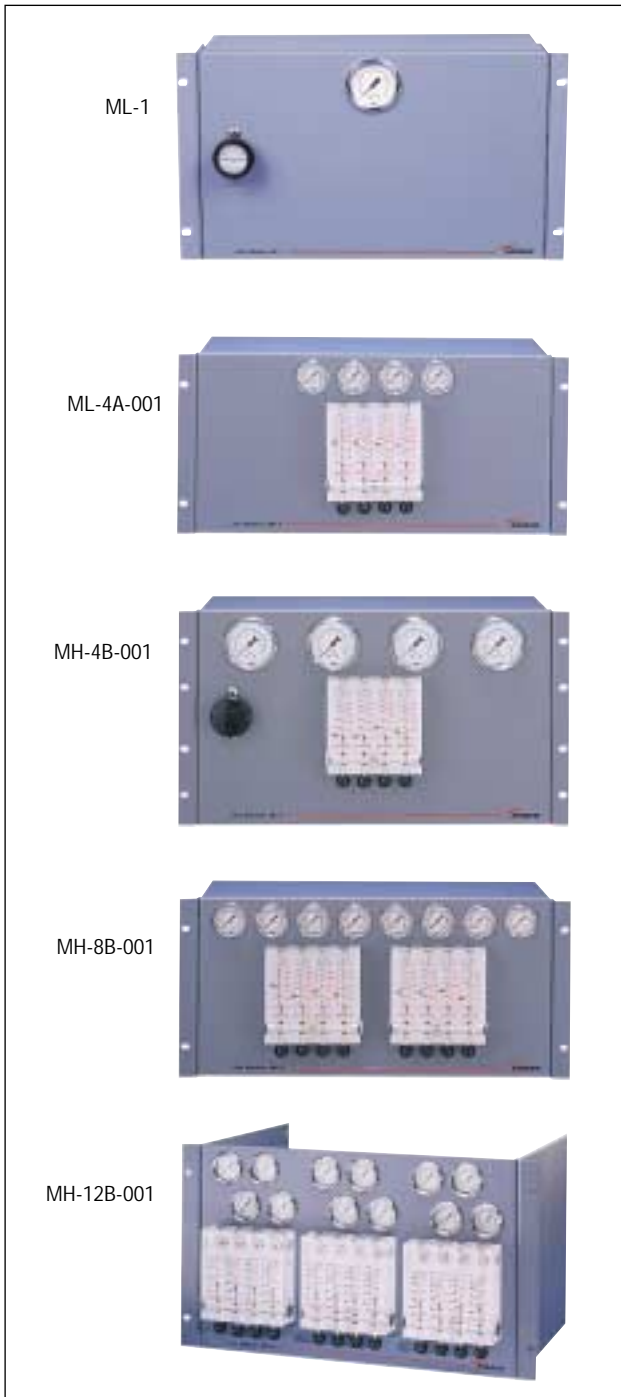

For multiple line MT dehydrator applications the ML- and MH-series of Line Monitors offer a convenient and complementary method of dry air distribution, control and monitoring. The monitors may be used in any combination, with the maximum number of lines to be pressurized limited only to the actual dehydrator capacity.

The monitoring function includes three items: a front panel gauge that displays the individual line pressure in lb/in² and kPa; an in-line flow meter; and a push-type shutoff valve. These functions are grouped in blocks of four interconnected at the rear of the unit to the main air inlet. The installation kit includes a tubing “tee” that allows monitors to be ganged together in various combinations.

The ML-1 Line Monitor (not shown) contains a low pressure tank and regulator which is adjustable from 0-2 lb/in² (0-14 kPa) and a 0-2 lb/in² (0-14 kPa) pressure gauge. The ML-4 Line Monitor contains the same, plus flow meters. ML- Line Monitors are intended primarily for use on low-pressure systems and require additional air volume between the MT DryLine[®] dehydrator (MT300 and larger) and the line monitor. For some applications, an additional external tank may be required to provide the additional volume. MT050 dehydrators have their own internal volume tank.

The MH series contains 0-15 lb/in² (0-105 kPa) pressure gauges and flow meters, but not regulators or tanks. Flow meters contain shut-off valves.

Installation Kits – Each four-port line monitor includes one four-line installation kit. Eight-port monitors include two four-line kits; twelve-port monitors include three four-line kits. The four-line kit contains 100 ft (30.5 m) of 3/8" polyethylene tubing, four tubing mounting racks, 24 nylon ties, four 1/8" NPT to 3/8" male tubing connectors, four 1/8" NPT street elbows, four 3/8" connector sleeves, one roll Teflon[†] tape, eight plastic inserts and one 3/8" tubing tee.

Mounting – Line monitors are equipped with uni-mounts for rack or wall mounting.

[†] Teflon[®] is a registered trademark of E.I. du Pont de Nemours & Co., Inc.

Series	ML-1-001	ML-4A-001	MH-4B-001	MH-8B-001	MH-12B-001
Number of Ports	1	4	4	8	12
Dimensions, in (mm)	10.5 x.16.7 x 7.6 (266 x 425 x 194)	10.5 x.16.7 x 7.6 (266 x 425 x 194)	8.72 x.16.7 x 7.6 (222 x 425 x 194)	8.72 x.16.7 x 7.6 (222 x 425 x 194)	10.5 x.16.7 x 7.6 (266 x 425 x 194)
Rack Units, RUs	6	6	5	5	6
Net Weight, lb (kg)	20 (9)	25 (11)	14 (6)	16 (7)	21 (10)

XH Line Monitors

Multiport Control/Gas Distribution Monitors for XT Series Dehydrators



Pressurization

Applications – Each XT300/-600/-1700 dehydrator must have an XH line monitor for microprocessor control. The XT4500 dehydrator includes a built-in microprocessor control.

Multiple Lines – The XH line monitors are available in one, four and eight port versions. Distribution panels (DP-4), manifolds (6600 series) and M series monitors (page 257) may be used in combination with the required XH line monitor to provide lines in addition to those provided by the XH line monitor.

Features – The XT series dehydrator/line monitor combination includes advanced features, in addition to the features listed for the MT series on pages 252-253.

All models feature LCD display for total run time and system pressure for each line. Four and eight line models include a built-in manifold and flow meters. External regulators and tanks can be used if multiple pressures are required. See page 266. They may also be programmed in English (factory set), Spanish, French, German and metric or imperial units.

Installation Kits – Each four-port line monitor includes one four-line installation kit. Eight-port monitors include two four-line kits. The four-line kit contains 100 ft (30.5 m) of 3/8" polyethylene tubing, four tubing mounting racks, 24 nylon ties, four 1/8" NPT to 3/8" male tubing connectors, four 1/8" NPT street elbows, four 3/8" connector sleeves, one roll Teflon[†] tape, eight plastic inserts and one 3/8" tubing tee. Note: When installing the air lines to the line monitor, they must be installed in order beginning with the number 1 port.

[†] Teflon[®] is a registered trademark of E.I. du Pont de Nemours & Co., Inc.

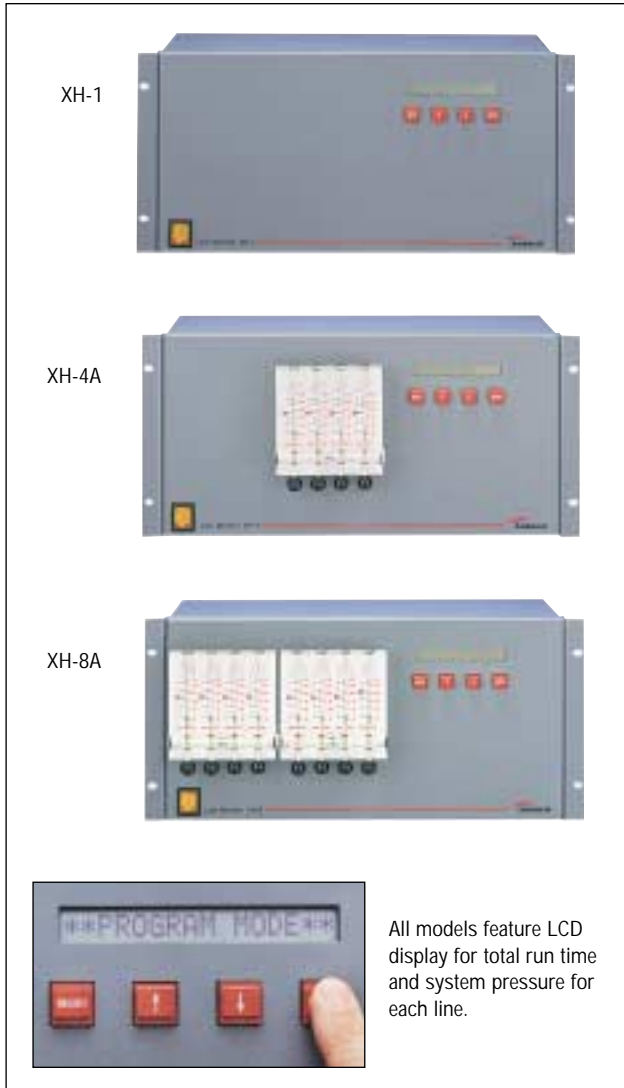

All models feature LCD display for total run time and system pressure for each line.

Standard Units		Redundant Hot Standby Units		Low Pressure Alarm	Excess Run Alarm	High Humidity Alarm	High Pressure Alarm
115 Vac 60 Hz	220 Vac 50 Hz	115 Vac 60 Hz	220 Vac 50 Hz				
XH-1-101	XH-1-102	XH-1-111	XH-1-112	•	•		
XH-1-701	XH-1-702	XH-1-711	XH-1-712	•	•	•	•
XH-4A-101	XH-4A-102	XH-4A-111	XH-4A-112	•	•		
XH-4A-701	XH-4A-702	XH-4A-711	XH-4A-712	•	•	•	•
XH-8A-101	XH-8A-102	XH-8A-111	XH-8A-112	•	•		
XH-8A-701	XH-8A-702	XH-18A-711	XH-8A-712	•	•	•	•

Series	XH-1	XH-4A	XH-8A
Number of Ports	1	4	8
Power Consumption, Watts	6	6	6
Dimensions, in (mm)	8.72 x 16.7 x 7.6 (222 x 425 x 194)	8.72 x 16.7 x 7.6 (222 x 425 x 194)	8.72 x 16.7 x 7.6 (222 x 425 x 194)
Rack Units, RUs	5	5	5
Net Weight, lb (kg)	15 (7)	17 (8)	20 (9)

For more information

F A X
Bulletin
1 6 6 0
See page 1

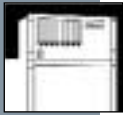

DryLine[®] MT/XT Series

Advanced, Automatic Regeneration, World Class Dehydrators

The DryLine dehydrator is the industry's most advanced system for pressurizing transmission lines. It sets new standards for drying performance. MTBF is as high as 55,000 hours (per MIL-HDBK-217F), double the industry standard. Units are warranted for three years or 3000 hours of compressor run time.

Great Convenience – A complete pressurization system is available in a convenient, two chassis DryLine package - the dehydrator and the line monitor. The package contains all of the components typically needed to pressurize an antenna/transmission line system. Depending on the options selected, these include the dehydrator compressor, output pressure regulator, pressure tank, manifold, alarm sensors and contacts, pressure gauges and flow meters. In other systems, these components typically have to be ordered separately and pieced together on site. A unique feature permits you to mount the line monitor panel in your equipment rack and locate the dehydrator/compressor in a remote area.

Low Noise and Vibration – All DryLine dehydrators are carefully balanced and custom isolated to minimize noise. In addition, a factory installed sound deadening option is offered which further reduces noise levels to as low as 82 dBA, on some models and 67 dBA on the MT050. That is less than the sound emitted by a computer dot matrix printer. The low noise and vibration now make it practical to mount DryLine dehydrators directly into radio equipment racks, even in attended systems.

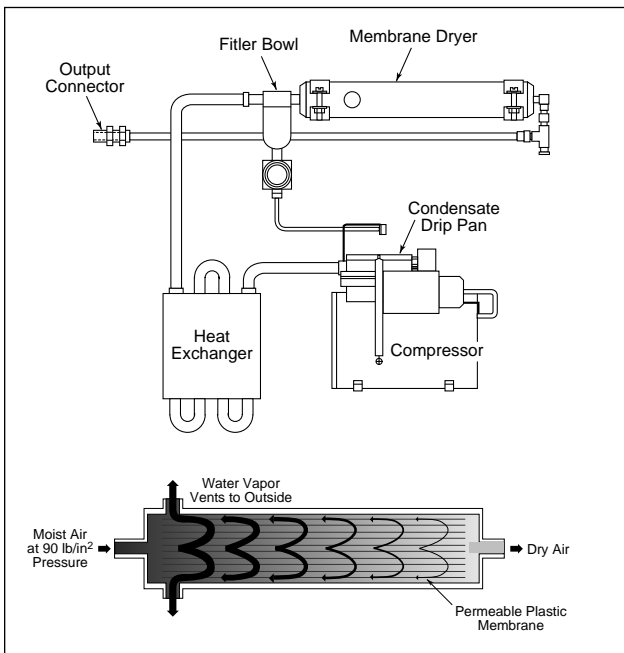

State-of-the-Art Monitoring and Control Features –

Even the basic DryLine dehydrators include a built-in low pressure alarm, a pressure gauge and a total run time meter. Optional features include adjustable output pressure, low pressure tank and regulator, a full range of programmable alarms, microprocessor control and LCD displays. Displays on programmable units are in four languages and in both imperial and metric units.

Easy Installation – The uni-mount chassis design permits rack, floor or wall mounting with included hardware for the larger units. No additional parts are required. MT-050 requires a shelf for wall mounting.

Membrane dryers offer exceptional reliability and a dewpoint better than -45°C (-50°F). They are fully "automatic" in that they automatically respond to the pressure requirements of the system and do not require regeneration due to use of a patented membrane and feedback system.

Importance of Open System Concept – The feedback system utilizes a small amount of the dry air to flow back through the dryer cartridge until the compressor again responds to the system. The advantages are (1) continual system drying; (2) elimination of moisture stratification in the system; and (3) elimination of the saturated towers found on small systems using pressure swing adsorption dehydrators. The low volume MT050 contains an internal feedback path that operates independently of the volume of the transmission line.

Applications – Membrane dryers are ideal for use on any system requiring fully automatic dehydration from 0.1 ft³ (3 liters) to 2,500 ft³ (70,800 liters) in volume. They will supply dry air at a dewpoint better than -45°C (-50°F) under the ambient conditions of 95% RH at 49°C (120°F).

Referring to the top diagram, the patented drying system begins when filtered ambient air is compressed. Afterwards, it flows through a heat exchanger which condenses some of the moisture, then it is separated out of the air stream by a filter. The separated water is evaporated in a pan on the head of the compressor.

The saturated air then passes into the membrane (bottom diagram) where moisture is separated by a permeation process through an inert, maintenance-free fiber material. The separated moisture is purged from the membrane into the atmosphere.

The specific patented membrane is constructed to allow the wet purge air to be somewhat enriched in oxygen and the dry output air to be somewhat depleted in oxygen. As the feed air contains only trace amounts of hydrogen, neither purge nor output air can contain a significant amount of hydrogen. The heat of compression and a 0.05 micron filter also prevent the growth or passage of bacteria.

Typical Systems Using Dehydrators (Except XT Series)

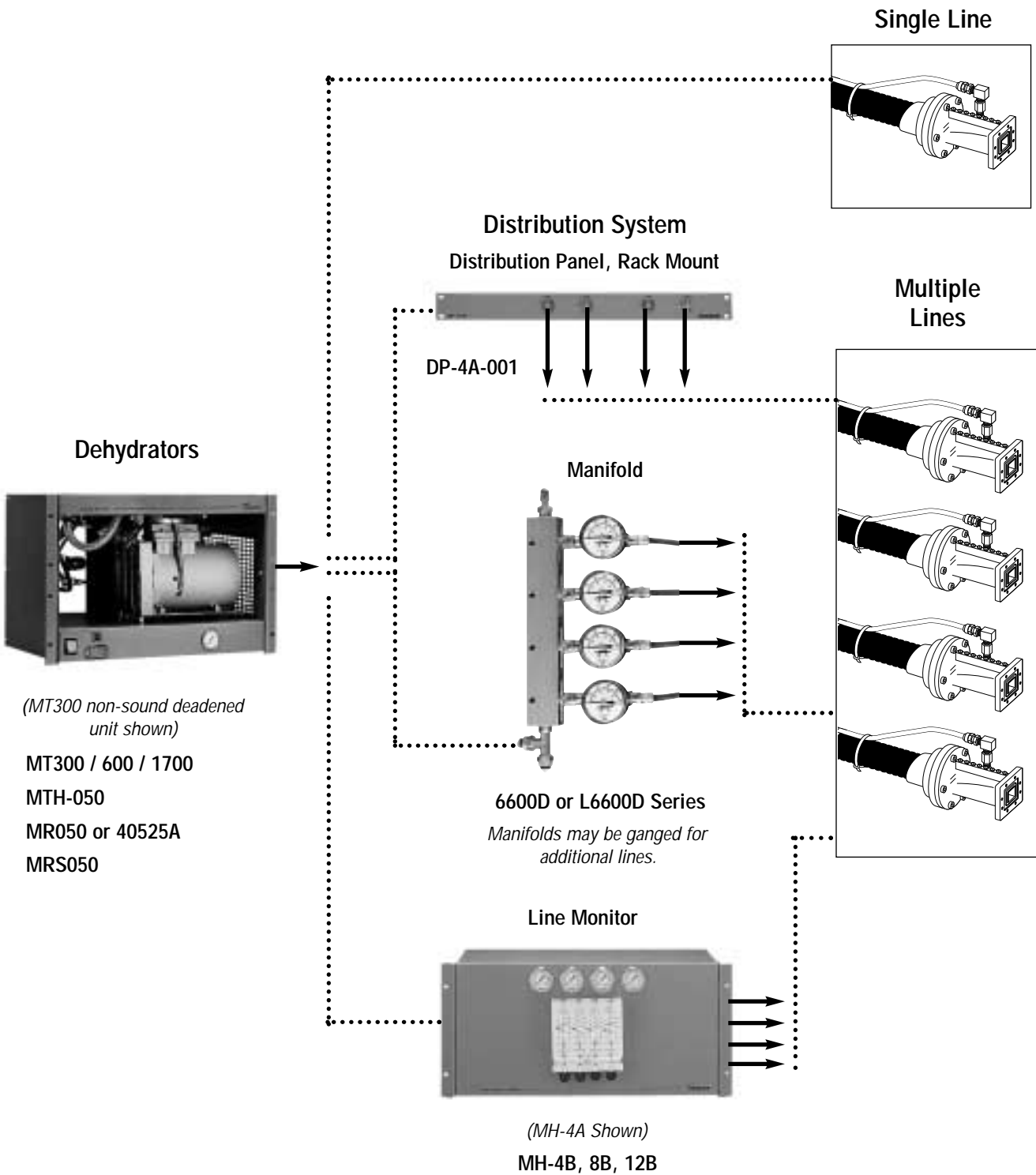



Dehydrator Systems Using Programmable XT-Series

Pressurization

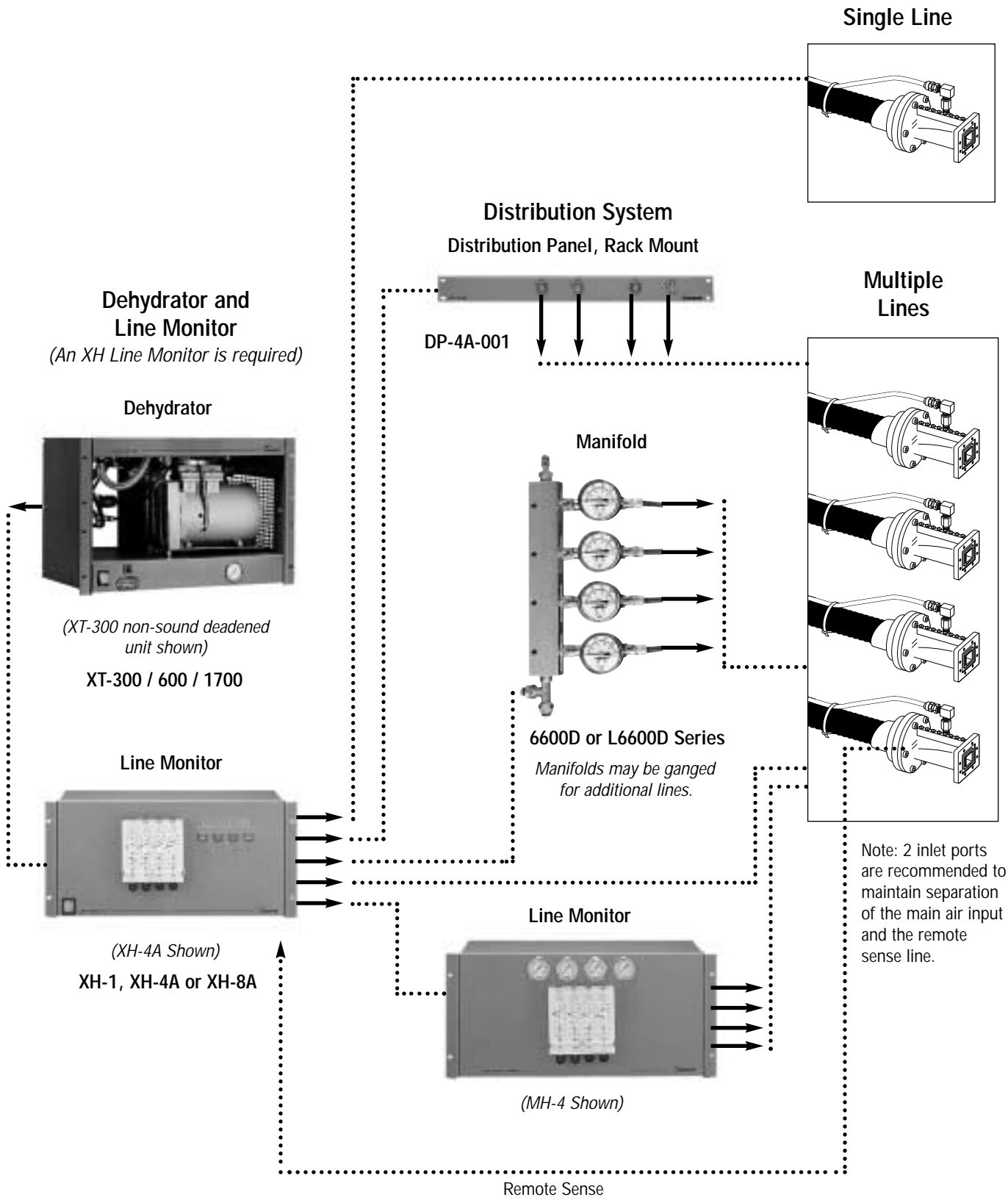

Typical Applications of a Static Desiccator

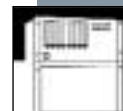

Static Desiccator SD-001 attached to Microwave Antenna Feed.



Static Desiccator SD-002A attached to 2 Port Combiner of 4.5 m ESA.



Static Desiccator SD-002A attached to HELIAX® Elliptical Waveguide Connector.



Dehydrator Selection Pressurization Worksheet

Protection of your transmission line system depends on the proper selection of your dehydrator. The following steps make it easy. *Visit the Andrew web site at www.andrew.com to download PSI Select software, which automates the calculations described below.*

1 Calculate Total Site Transmission Line Volume

Using the following equation and the table to the right, determine the volume of each transmission line. Add the volumes to obtain the total site volume.

Site # _____

Example: Data from column to the right

$$\frac{\text{Volume} \times \text{Length}}{1000} = \text{cubic feet (liters)}$$

$$\text{Line \# } \underline{1}, \text{ Size } \underline{7/8"}, \text{ Length } \underline{450 \text{ ft}}; \text{ Vol } \underline{3.5 \text{ ft}^3} \times \text{L } \underline{450 \text{ ft}} = \underline{1.57 \text{ cu ft (liters)}}$$

2 Select Optimum Dehydrator Based Upon Total Site Volume

3 Calculate Purge, Pressurizing and Cycle Times

Purging the System

Before putting your transmission line system into service, purge each line to remove the moist air that was trapped inside during installation. Leave a flange(s) open at the antenna end and operate the dehydrator until the volume has been changed at least three times. Secure the flange(s).

If the above method is not possible, create a leak in the tubing fitting prior to the manifold/line monitor so that the dehydrator pressurizes the system every 60 minutes. Allow the dehydrator to run overnight and then retighten the fitting.

Purge time (in minutes) can be estimated by dividing the total system volume by the dehydrator flow rate from page 247 and 248 and then multiplying the result by 3.

Pressurizing the System

Once the system has been purged, dehydrator run time becomes a function of the start and stop pressures used in the system and the flow rate of the dehydrator. PSI Select software automatically performs a cycle time calculation during the dehydrator selection process.

For a copy of the software, please visit our web site at www.andrew.com for a free download or contact Andrew.

Cycle Time

Cycle time will vary by the type of dehydrator and the quality (tightness) of the system. Continuous length flexible transmission lines, such as HELIAX® air-dielectric coaxial cable and elliptical waveguide form the tightest systems, since there is a flange only at each end of a line. Rigid line, rectangular waveguide and other multiple flanged systems have more opportunity for air to release to the outside and they will exhibit higher leak rates.

Performance of the transmission line can be verified after purging and initial pressurization, by shutting off the air supply for 24 hours with a main air valve and observing changes in pressure. A general rule is that pressure should not drop more than 1 psi (7 kPa) during the 24-hour period. [Most systems will exhibit much lower leak rates in the range of 2 to 8% of air volume, which would register as less than a 0.4 psi (2.8 kPa) drop on a 5 psi (35 kPa) system]. After a leak test, restore the system to normal operation by opening the system air valve. On membrane systems, disconnect the output line and run the dehydrator into the room for 60 minutes before reconnecting to the system.

Dehydrator duty cycle can be used to quantify leak performance of the transmission line. Time the compressor on time of a typical cycle and the total time between cycles. The ratio of run time to total time should be less than 4% for MR/MRS and 40525A dehydrators and 8% for MT and XT dehydrators. The longer duty cycles for the membrane units is due to a controlled bleedback from the system into the membrane tube, which is a characteristic of the unique design of these units.



Transmission Line Data

Line Type		Volumes	
		ft ³ 1000 ft	liters 1000 m
HELIAX® Pressurizable Coaxial Cable			
1/2"	HJ4-50	0.68	63
5/8"	HJ4.5-50	1.92	178
7/8"	HJ5-50	3.5	325
1-1/4"	LDF6-50	1.7	158
1-5/8"	HJ7-50A	14.0	1301
2-1/4"	HJ12-50	21.5	1997
3"	HJ8-50B	36.7	3410
4"	HJ11-50	69.9	6494
5"	HJ9-50	117.0	10870
SCL-950		512	47570
HELIAX Elliptical Waveguide			
EW220	21.2-23.6 GHz	0.8	74
EW180	17.7-19.7 GHz	1.2	111
EW132	14.0-15.35 GHz	1.8	167
EW127A	11.7-13.25 GHz	2.7	251
EW90	10.5-11.7 GHz	3.6	334
EW85	8.5-9.8 GHz	4.2	390
EW77	7.125-8.5 GHz	6.3	585
EW64	7.125-7.750 GHz	7.8	725
EW63	6.425-7.125 GHz	9.2	855
EW52	5.6-4.25 GHz	11.3	1045
EW43	4.4-5.0 GHz	18.2	1690
EW37	3.58-4.26 GHz	21.1	1960
EW34	3.58-4.26 GHz	25.0	2323
EW28	2.9-3.4 GHz	36.0	3345
EW20	2.5-2.7 GHz	60.5	5621
EW17	1.7-2.3 GHz	71.0	6596
Circular Waveguide			
WC109		6.5	604
WC166		15.0	1394
WC205		22.9	2127
WC269		39.5	3670
WC281		43.1	4002
Rigid Transmission Line			
7/8"		3.36	312
1-5/8"		12.6	1171
3-1/8"		48.7	4524
6-1/8"		194.0	18023
GUIDELINE® Waveguide			
GLW-1350		994	92343
GLW1500		1227	113988
GLW1700		1576	146410
GLW1750		1670	155143
Rectangular Waveguide			
WR42	17.7-26.5 GHz	0.5	46
WR62	12.4-18.0 GHz	1.3	124
WR75	10.0-15.0 GHz	2.0	181
WR90	8.2-12.4 GHz	2.5	232
WR112	7.05-10.0 GHz	3.9	362
WR137	5.85-8.2 GHz	6.0	551
WR159	4.9-7.05 GHz	8.8	817
WR187	3.95-5.85	11.3	1053
WR229	3.3-4.9	18.2	1691

Antenna Feed Pressure Ratings

Caution: UMX-459,-465,-611; UHX-34,-35,-36,-37; HPX12-6511C; FP/FPX-34,-36; and P-186 antennas have lower pressure ratings than standard antennas as indicated in the chart below.

Antenna	Max. Pressure Rating, lb/in ² (kPa)
UMX-459	0.5 (3.5)
UMX-465	5 (35)
UMX-611	5 (35)
UHX-34,-35,-36,-37	5 (35)
FP/FPX-34,-36	5 (35)
HPX12-6511C	5 (35)
P-186	2 (14)
2 GHz Dual Polarized UHX	3 (21)

Commonly Used Conversion Factors

U.S. Customary Units (Imperial)

- 1 lb/in² = 69 mbar = 6.9 kPa
- 1 in H₂O = 0.04 lb/in² = 25.4 mm H₂O = 0.25 kPa
- 1 SCFM = 60 SCFH = 1670 l/hr
- 1 gal = 0.134 ft³ = 3.78 liters
- 1 ft³ = 7.48 gal = 28.32 liters = 0.028 m³
- 1 in = 25.4 mm = 2.54 cm

SI Units (Metric)

- 10 kPa = 100 mbar = 1.45 lb/in²
- 100 mm H₂O = 1 kPa = 0.14 lb/in² = 4.01 in H₂O
- 100 l/hr = 3.53 SCFH = 0.059 SCFM
- 1 liter = 0.26 gal = 0.04 ft³
- 1 m³ = 1,000 liters = 35.3 ft³ = 259.7 gal
- 1 cm = 10 mm = 0.39 in

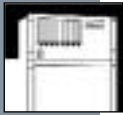

Pressurization Accessories

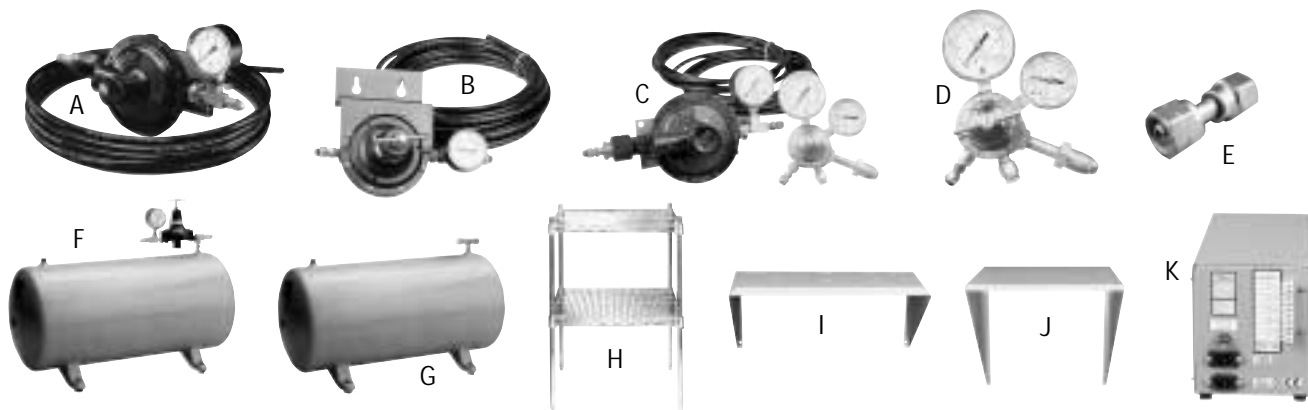

Low Pressure Components

- A Low-Pressure, Fixed, Wall-Mount Regulator**, is factory set to reduce the pressure of microwave pressurization systems (typically 3-8 lb/in²), to 0.4 lb/in² (3 kPa). The regulator is supplied with a wall mounting bracket, 20 feet (6 m) of 3/8" polyethylene tubing and a 1/8" NPT male connector for attachment to the HELIAX® coaxial cable or waveguide. Not to be used directly from any dehydrator except 40525A and MT050.Type **42996A**
- B Low-Pressure, Adjustable, Wall-Mount Regulator**, is user set to reduce the pressure of microwave pressurization systems (typically 3-8 lb/in²), to any value between 1 and 5 lb/in² (7 to 34 kPa). The regulator is supplied with a wall mounting bracket, 25 ft (7m) of 3/8" polyethylene tubing and a 1/8" NPT male connector for attachment to coaxial cable or waveguide. Not to be used directly on any dehydrator except 40525A and MT050.Type **AE01A-D1339-001**
- C Nitrogen Regulator with fixed Low-Pressure Assembly**. Includes a wall-mount regulator, Type 42996A (described above) factory set at 0.4 lb/in² and a Nitrogen regulator assembly, factory set to 10 lb/in² (70 kPa), with high and low-pressure gauges for direct attachment to a nitrogen tank with a CGA 580 (0.965" right hand internal) connection. It is supplied with 25 feet (7 m) of 3/8" tubing and 1/8" NPT male pipe connector for attachment to the HELIAX coaxial cable or waveguide connectors.Type **42969**
- D Nitrogen Regulator**. Adjustable 0-15 lb/in² (0-103 kPa) includes a pressure regulator, high- and low-pressure gauges, and 25 feet (7 m) of 3/8" polyethylene tubing and 1/8" NPT male connector. Fits CGA580 (0.965" right-hand internal) connection.Type **858C**
Fits British 5/8" BSPP connectionType **858C-3**
- E Adapter** to fit a CGA555 (0.903" left-hand external) nitrogen tank connection and mates to CGA 580 connectionType **35751**
- F Regulating Tank**, 1-5 lb/in² (7-34 kPa). Use with small dehydrators to increase system volume. Prevents excessive cycling in low volume systems. Also used in 2 or 4 GHz systems to reduce maximum pressure to 5 lb/in² (34 kPa). The tank has a 1.5 ft³ (42 liter) capacity and is supplied with a 0-5 lb/in² gauge. The regulator can be adjusted down to 1.0 lb/in² (7 kPa) output pressure. Includes 25 feet (7 m) of 3/8" polyethylene tubing and one 1/8" NPT male connector. 20 H x 12 W x 27 L inches (510 x 305 x 685 mm). Net weight 33 lb (15 kg).....Type **31614-3**
- G AirTank**. Use with any dehydrator to increase system volume by 1.5 ft³ (42 liters). Includes 3/8" tubing tee to prevent excessive cycling when pressurizing low volume systems, such as 1/2" and 7/8" cables. 17 H x 12 W x 27 L inches (432 x 305 x 685 mm). Net weight 30 lb (14kg).....Type **31614-4**
- H Floor Stand**. For 40525A, MT and XT series dehydrators and regulating tanks. Includes two shelves 17.75 in by 23.3 in (450 x 590 mm). Allows for convenient placement of dehydrator above regulating tanks.Type **30900**
- I Wall Shelf**. For 40525 series. Can also be mounted to a 19" equipment rack.Type **30895**
- J DryLine® Wall Shelf**.
For MT050 seriesType **AE01A-D1306-003**
For MT/XT300/600 series.....Type **AE01A-D1306-004**

Alarm Monitors

Low pressure, high pressure, high humidity, power failure, and excess run pressurization monitors activate remote warning light or alarm (not supplied) when system pressure, humidity or run time goes beyond specified limits.

- K 40004 Series Monitors** are for use with 40525A Dehydrators or where full alarms are needed if not included in dehydrator.

The **40004C-015** is for use on 115 Vac.
The **40004C-026** is for use on 230 Vac.



Pressurization Accessories

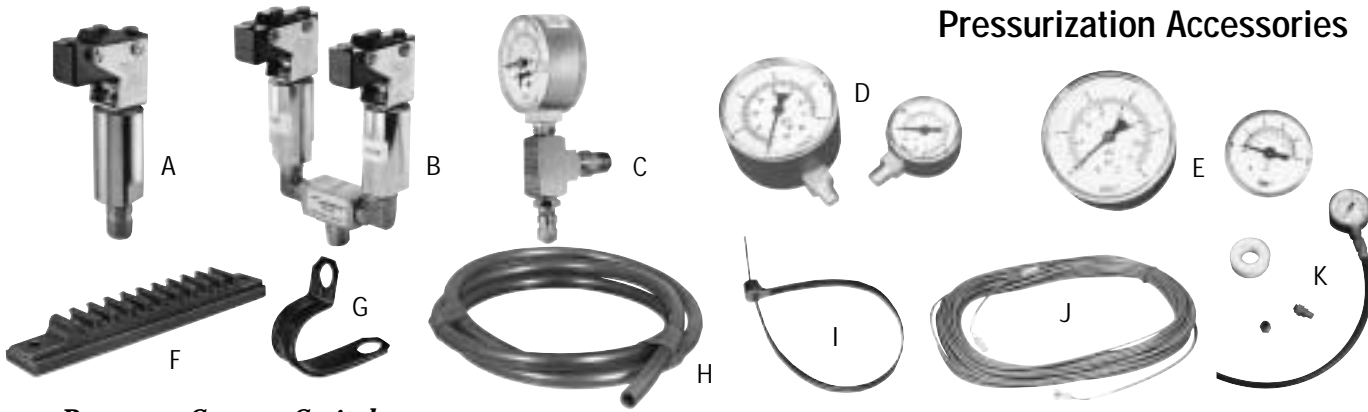

Pressure Sensor Switches

Can be used to activate remote warning lights or alarms when system pressure goes beyond specified low or high limits. Pressure activated, normally open, Form C, dry contacts, 3 amps resistive.

A Single Switch. Low or high-pressure limit, adjustable 0-20 lb/in² (0-140 kPa).

Low-Pressure Limit factory set at 1.25 lb/in² (8.6 kPa). Includes 3/8" poly tube tee fitting for line insertion.Type **31618-1**

High-Pressure Limit factory set at 10 lb/in² (70 kPa). Includes 3/8" poly tube tee fitting for line insertion.Type **31618-2**

Low-Pressure Limit factory set at 1.25 lb/in² (8.6 kPa). Includes 1/4" NPT fitting for mounting on top of manifold.Type **31618-4**

B Dual Switch. Low and high-pressure limits, adjustable 0-20 lb/in² (0-140 kPa). Pressure activated, normally open, Form C, dry contacts, 15 amps resistive.

High-Pressure Limit factory set at 3 lb/in² (21 kPa).
Low-Pressure Limit factory set at 1.25 lb/in² (8.6 kPa). Includes 1/4" NPT fitting for mounting on top of manifold.....Type **165046**

High-Pressure Limit factory set at 10 lb/in² (70 kPa).
Low-Pressure Limit factory set at 1.25 lb/in² (8.6 kPa). Includes 1/4" NPT fitting for mounting on top of manifold.Type **165046-2**

Pressure Gauges

C Gauge Assembly. Indoor use only. Includes pressure gauge with steel case, gas inlet valve and tee with 1/8" NPT male pipe thread. Dual scale graduated in lb/in² and kPa.

0-30 lb/in² and 0-200 kPa.Type **18991A-1**

0-15 lb/in² and 0-100 kPaType **18991A-2**

D Pressure Gauge. Indoor use only. Steel case. Bottom fitting. Male pipe thread. Dual scale graduated in lb/in² and kPa.

0-15 lb/in² and 0-100 kPa with 1/8" NPT thread.Type **3500A**

0-5 lb/in² and 0-35 kPa with 1/8" NPT thread.Type **33117-2**

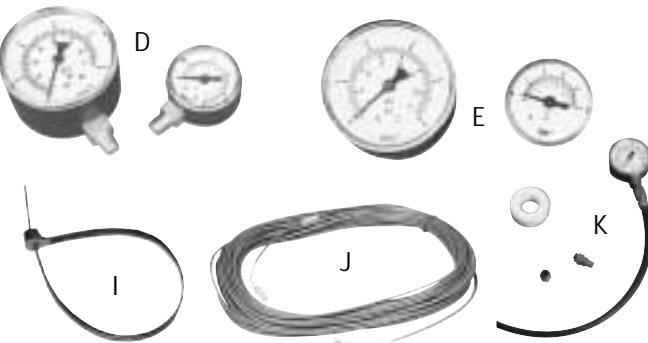

E Pressure Gauge. Indoor use only. Steel case. Back Fitting. Male pipe thread. Dual scale graduated in lb/in² and kPa.

0-15 lb/in² and 0-100 kPa with 1/8" NPT thread.Type **3500A-2**

0-5 lb/in² and 0-35 kPa with 1/4" NPT thread.Type **33117-5**

Installation Accessories

F Mounting Rack, UV resistant, for polyethylene tubing. Hardware for wall mounting not included.

For 1/4" tubes (package of 10)Type **AE01K-B0523-001**
For 3/8" tubes (package of 10)Type **AE01K-B0523-002**
For 1/2" tubes (package of 10)Type **AE01K-B0523-003**

G Mounting Strap, UV resistant, for polyethylene tubing.

For 1/4" tubes (package of 10)Type **164004-3**
For 3/8" tubes (package of 10)Type **164004-1**
For 1/2" tubes (package of 10)Type **164004-2**

H Polyethylene Tubing, UV resistant, for indoor/outdoor applications. Specify length in feet or meters.

1/4" tubing. Maximum length 1000 ft (305 m); minimum length 20 ft (6 m)Type **25435-4**

3/8" tubing. Maximum length 500 ft (150 m); minimum length 20 ft (6 m)Type **25435-5**

1/2" tubing. Maximum length 250 ft (75 m); minimum length 20 ft (6 m)Type **25435-8**

I Nylon Tie Kit, UV resistant, for securing polyethylene tubing directly to interior or exterior waveguide.

Package of tenType **164027**

J Signal Extension Cable for XT Pressurization System. Install XT Series dehydrator up to 100 ft from XH Series line monitors.

50 ft (15 m) lengthType **AE01C-D0534-050**
100 ft (30 m) lengthType **AE01C-D0534-100**

K Back Pressure Regulator Test Gauge. Testing/setting for MT/XT300/600/1700 units ...Type **AE01A-D1402-001**



Pressurization Accessories

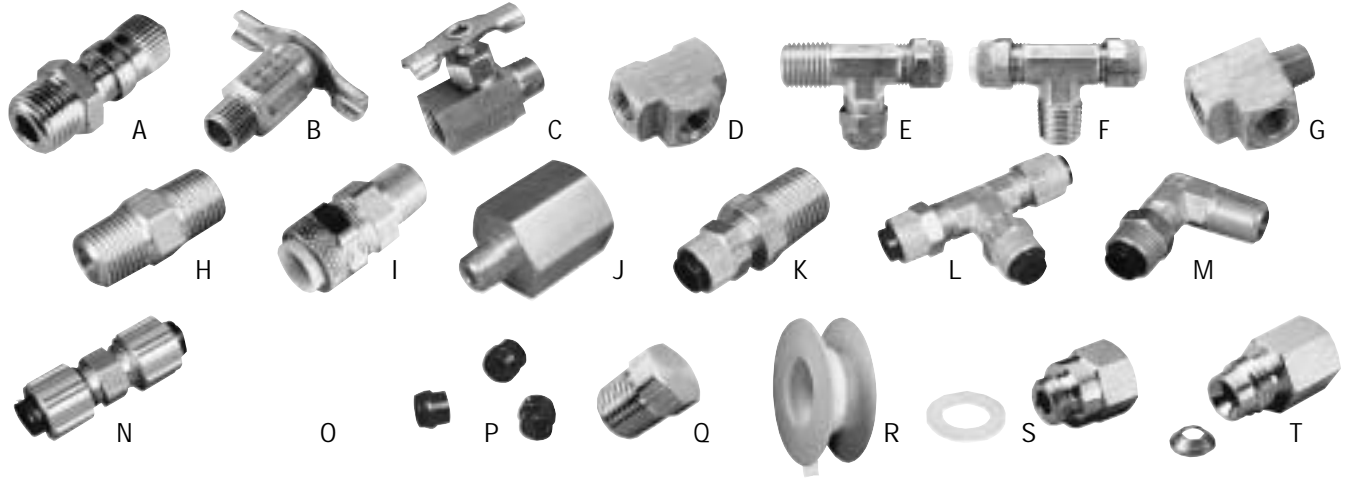

Fittings

- A Gas Inlet Valve.** Has male threads and cap.
1/8" NPT threadType **3017**
1/4" NPT threadsType **3017-2**
- B Gas Release Valve.** Has male threads.
1/8" NPT threadsType **3027**
- C Gas Shut-Off Valve.** Has male thread one end and female thread other end.
1/8" NPT threadsType **4949**
3/8" poly tube to 1/4" male NPT (40525A)Type **25436-73**
3/8" poly tube to 3/8" poly tube (install kits)Type **AE01J-A0133-040**
- D Pipe Tee.** Has female threads each outlet.
1/8" NPT threadsType **3028**
1/4" NPT threadsType **3028-2**
- E Male Run Pipe Tee** has 1/4" NPT pipe threads and two 3/8" poly tube outletsType **25436-69**
- F Male Branch Tee** has one 1/4" NPT male outlet and two 3/8" poly tube outletsType **25436-62**
- G Street Tee** has one 1/8" NPT male and two 1/8" NPT female outletsType **3022**
- H Hex Pipe Nipple** has male threads both ends.
1/8" NPT threadsType **25436-42**
1/4" NPT threadsType **25436-52**
- I Male Connector** for polyethylene tubing.
For 1/4" tubing 1/8" NPT male pipe thread.Type **25436-20**
For 3/8" tubing 1/8" NPT male pipe thread.Type **25436-68**
For 1/2" tubing 3/8" NPT male pipe thread.Type **25436-84***
- J Reducing bushing**
3/8" female NPT to 1/8" Male NPTType **25436-83**
- K Male Connector** for polyethylene tubing. 1/4" NPT male pipe thread.
For 1/4" tubingType **25436-61**
For 3/8" tubingType **25436-63**
- L Tee** for polyethylene tubing.
For 1/4" tubingType **25436-519**
For 3/8" tubingType **25436-81**
- M Elbow** for polyethylene tubing to NPT male pipe thread.
For 1/4" tubing 1/8" NPT male pipe threadType **25436-21**
For 3/8" tubing 1/8" NPT male pipe threadType **25436-4**
For 3/8" tubing 1/4" NPT male pipe threadType **25436-64**
For 1/2" tubing 3/8" NPT male pipe threadType **25436-85***
- N Splice Union** for polyethylene tubing.
For 1/4" tubingType **25436-522**
For 3/8" tubingType **25436-32**
For 1/2" tubingType **25436-526**
- O Bulkhead Union** for poly tubing
3/8" poly tube to 3/8" poly tubeType **25436-71**
- P Compression sleeve**
For 1/4" poly tube bag of 10Type **25436-75-10**
For 3/8" poly tube bag of 10Type **25436-50-10**
For 1/2" poly tube bag of 10Type **25436-33-10**
- Q Pipe Plug.** Has 1/8" NPT male threadsType **EFTGP-27720**
- R Teflon[†] Tape** for sealing threaded joints.
7.5 ft (2.2 m) of tape on spool.....Type **3012A**
- Metric Gas Inlet Adapters**
- S M10X .75-6G** metric adapter to 1/8" NPT for H4PDM, H5PDM-T and H4.5PDM connectorsType **AE01K-CO677-001**
- T M12X 1.5-6G** metric adapter to 1/8" NPT for H12PDM-T, H7PDM-T and L6PDM connectors.

*Use with 25436-83, 3/8" to 1/8" reducer. Order separately.

[†] Teflon[®] is a registered trademark of E.I. du Pont de Nemours & Co., Inc.

Pressurization Accessories



Pressurization



Maintenance Components

Replacement Air Filter Cartridge, includes filter

- A For 1920/1930 and XT4500 series dehydrators
.....Type **46173**
- B For MT/XT300 series.....Type **EFLTR-20201**
- C For MT/XT -600, -1700 series.....Type **EFLTR-20202**
- D For MR/MRS050 series dehydrators
.....Type **AE01J-A0196-001**
- E For MR-052 (AC only) early units
.....Type **AE01J-A0132-003**

Replacement Air Filters (Element Only)

- F For 1920/1930 and XT4500 series units.
Package of six.....Type **46173-1**
- G For MT/XT300 series units. Package of six.
.....Type **AE01K-B0518-001**
- H For MT/XT-600, -1700 series units.
Package of six.....Type **AE01K-B0518-002**
- I **Color Indicating Silica Gel Refill.** For all sight
glasses on 1920/1930, 65630B/163903.
1 ounce package per sight glass...Type **AE01K-B0214**
- J **Color Indicating Silica Gel Refill.** For Type 860A/878A
hand pump (requires one can) or Type 40525A
dehydrator (requires two cans)Type **210**

- K **Color Indicating Calcium Sulfate** for MR-50 series
dehydrators. Use one 1.25 lb (0.56 kg) package per
canister.....Type **AE01K-C0561-001**
- L **Color Indicating Calcium Sulfate** for MR/MRS050
series dehydrators, 2.5 lb (1.2 kg)
.....Type **AE01K-C0561-002**
- M **Color Indicating Calcium Sulfate** for MR/MRS050
series dehydrators. Six bags, 2.5 lb (1.2 kg) each.
.....Type **AE01A-D1266-004**
- N **Replacement Canister with Desiccant and Hose**
for MRS050 series dehydrators. Two complete
canisters per boxType **AE01A-D1266-003**
- Replacement Canister with Desiccant without Hose**
for MR050 series dehydrators
.....Type **AE01K-D0817-001**
- O **Second Canister with Desiccant includes Hose**
for MR050 series dehydrators to increase capacity
.....Type **AE01K-D0817-002**
- P **Non-Color Indicating Sorbead Refill** for Type
65630B/163903 dehydrators. Requires one package.
5 lb (2.27 kg)Type **52665-2**
- Q **Pressure Swing Tower Overhaul Kit** for one
1920/1930 series dehydrator. Includes molecular
sieve, O rings, perforated disk and filter pads.
Solenoid valve not included.....Type **AE01K-B0187**



Pressurization Accessories

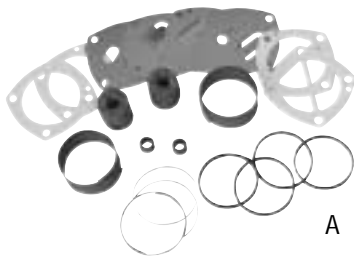

A

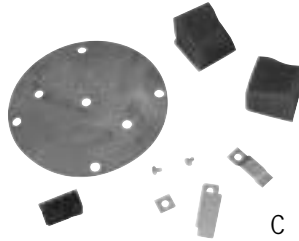

C



D

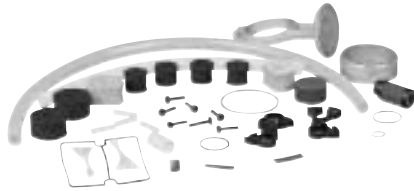

F

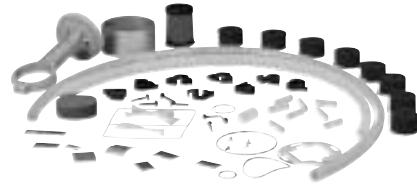

H



J

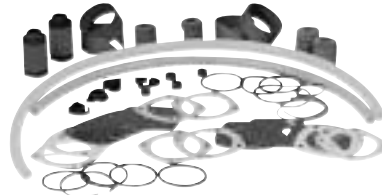

K



L

Pressure Swing Dehydrator Compressor Overhaul Kit. Includes gaskets, rings, seals and valves:

A For 1920/1921/1924 seriesType **39878**

B For 1930/1931/1934C seriesType **40486**
(Not illustrated)

Includes gasket, valves and muffler:

C For 40525A seriesType **39795-2**

Membrane Dehydrator Overhaul Kits.

Includes compressor overhaul kit, high temperature hose, clamps, isolators, water filter element and coalescent filter element.

D For MT050 series 115 Volt solenoid upgradeType **AE01K-D0820-001**

D For MT050 series 230 Volt solenoid upgradeType **AE01K-D0820-002**

E For MT050 seriesType **AE01K-C0398-007**
(Not Shown)

F For MT/XT300 series. For units equipped with green WILKERSON filtersType **AE01K-C0398-001**

F For MT/XT300 series. For units with compressor model No. 627CEGHType **AE01K-C0398-013**

G For MT/XT-600-()()1 series blue bowlType **AE01K-C0398-002**
(Not Shown)

G For MT/XT-600-()()2 series blue bowlType **AE01K-C0398-003**
(Not Shown)

H For MT/XT-1700-()()1 series blue bowlType **AE01K-C0398-004**

H For MT/XT-1700-()()2 series blue bowlType **AE01K-C0398-005**

I For MT/XT-1700-()()1 series black bowlType **AE01K-C0398-008**
(Not Shown)

I For MT/XT-1700-()()2 series black bowlType **AE01K-C0398-009**
(Not Shown)

J For MT/XT-600-()()1 series black bowlType **AE01K-C0398-011**

J For MT/XT-600-()()2 series black bowlType **AE01K-C0398-012**

K For XT4500Type **AE01K-C0398-010**

L **Spare Hose** for 860G and 878A series hand pump dehydrators. 7 feet (2.13 m) longType **10025**



Bulletin 1660



Bulletin 3550



Bulletin 10232



Bulletin 3551



Bulletin 1557



Bulletin 1845
Article reprint



Bulletin 10206
Article reprint



Bulletin 3579
Article reprint



Bulletin 3851
Article reprint

Literature

DryLine® Dehydrators

MT and XT series dehydrators. 8 pages. **Bulletin 1660**

MT050 data sheet. **Bulletin 3550**

XT4500 data sheet. **Bulletin 10232**

Dehydrators

MR050 data sheet. **Bulletin 1845**

MRS050 data sheet. **Bulletin 3551**

Use Pressurization to Protect RF Feedlines.

Magazine article reprint. 6 pages. **Bulletin 1845**

Nitrogen vs. Air Pressurization.

Magazine article reprint. **Bulletin 10206**

Pressurization Fundamentals.

Magazine article reprint. **Bulletin 3579**

Selecting dry air systems.

Magazine article reprint. **Bulletin 3851**

The Care and Feeding of your older Andrew Dehydrator.

Bulletin 1557

Computer Software



PSI Select

Pressurization planner performs air volume calculations, helps you to select the proper dehydrator, and provides all of the catalog information. A single source for Andrew pressurization information. Download PSI Select from www.andrew.com. It is also

available on the "Andrew Powertools" CD.

CD format. **Bulletin M400**

Dehydrator Repair and Free Loaner Program

Andrew maintains a repair center for pressurization equipment. Free loaner units are available for use while your equipment is being repaired by Andrew. Call Andrew Customer Service for details.

Repairable Dehydrators: Series, 40525A, 65630B, 163903, 78200-24/48, MT/XT300/600/1700/4500 Series, MT050 Series and MR/MRS-050 Series.