

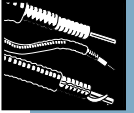

HELIAX[®]
Coaxial Cables



Index

General Information

HELIAX® Coaxial Cable	
Cable Selection Guide	442
Introduction.	450
HELIAX Coaxial Cable Types.	453
HELIAX Coaxial Cable...Today's Alternative to Braided Cable	459
Connectors	
HELIAX Connectors	462
New OnePiece™ Connectors	464
HELIAX Accessories	471
Factory Made Cable Assemblies	472
Ordering Information	473

Ordering Information and Specifications

HELIAX Coaxial Cables and Connectors	474
Factory Made Cable Assemblies	584
Phase Measured Cable Assemblies	588
GPS Antenna Kit	592
Accessories	593

Applications and Technical Information

Fire Retardant Cables and Waveguides	626
Intermodulation Generation	630
Technical Data	631

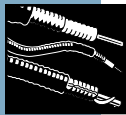

Coaxial Cable Selection Guide



HELIX[®] Coaxial Cable Selection Guide - 50-ohm, Foam Dielectric

Nominal Size Catalog Pages	Superflexible, FSJ Series			Extraflexible, EFX Series	Foam Dielectric, VXL Series
	1/4" 474	3/8" 480	1/2" 485	3/8" 489	7/8" 503
Standard Cables					
Standard Black Jacket	FSJ1-50A	FSJ2-50	FSJ4-50B	EFX2-50	VXL5-50
Fire Retardant Cables					
CATVX, VW-1, IEC 332-1	FSJ1RN-50B	FSJ2RN-50	FSJ4RN-50B	EFX2RN-50	VXL5RN-50
CATV, UL1581, IEC 332-3, IEEE 383	FSJ1RN-50B	FSJ2RN-50	FSJ4RN-50B	EFX2RN-50	VXL5RN-50
CATVR, UL1666 (Riser)	FSJ1RN-50B	FSJ2RN-50	FSJ4RN-50B	EFX2RN-50	VXL5RN-50
Low VSWR Cables, Specially Tested					
Standard Black Jacket	FSJ1P-50A-(**)	FSJ2P-50-(**)	FSJ4P-50B-(**)	EFX2P-50-(**)	VXL5P-50-(**)
Special Application Cables					
Phase Stabilized; Phase Measured	p. 590	p. 590	p. 590	-	-
Characteristics					
Maximum Operating Frequency, MHz	20400	13400	10200	13500	4900
Peak Power Rating, kW	6.4	13.2	15.6	15.6	90
Relative Propagation Velocity, %	84	83	81	85	88
Minimum Bend Radius, in (mm)	1 (25)	1 (25)	1.25 (32)	1.75 (45)	5 (125)
Attenuation, dB/100 ft (dB/100 m) Standard conditions: VSWR 1.0; ambient temperature 20° C (68° F).					
30 MHz	0.973 (3.19)	0.649 (2.13)	0.557 (1.83)	0.584 (1.92)	0.214 (0.702)
100 MHz	1.79 (5.89)	1.20 (3.94)	1.04 (3.41)	1.08 (3.56)	0.397 (1.3)
450 MHz	3.91 (12.8)	2.64 (8.66)	2.31 (7.59)	2.39 (7.83)	0.878 (2.88)
1000 MHz	5.96 (19.6)	4.06 (13.3)	3.60 (11.8)	3.68 (12.1)	1.36 (4.46)
2000 MHz	8.67 (28.5)	5.97 (19.6)	5.37 (17.6)	5.41 (17.8)	2.01 (6.59)
6000 MHz	16.1 (52.7)	11.3 (37.2)	10.5 (34.4)	10.3 (33.8)	-
10000 MHz	21.7 (71.2)	15.5 (50.8)	14.6 (47.9)	14.1 (46.3)	-
Average Power Rating, kW Standard conditions: VSWR 1.0; ambient temperature 40 °C (104° F); inner conductor temperature 100°C (212°F); no solar loading.					
30 MHz	2.28	3.97	5.76	3.99	12.3
100 MHz	1.23	2.14	3.09	2.15	6.62
450 MHz	0.567	0.975	1.38	0.978	2.99
1000 MHz	0.372	0.634	0.889	0.635	1.93
2000 MHz	0.256	0.431	0.598	0.431	1.31
6000 MHz	0.138	0.228	0.307	0.227	-
10000 MHz	0.102	0.166	0.220	0.165	-

** Insert suffix number from specific cable Catalog page. † See specific Catalog page.

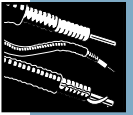

HELIX® Coaxial Cable Selection Guide - 50-ohm, Foam Dielectric

Foam Dielectric, LDF Series							
1/4"	3/8"	1/2"	5/8"	7/8"	1-1/4"	1-5/8"	2-1/4"
491	493	496	500	506	513	520	524
Standard Cables							
LDF1-50	LDF2-50	LDF4-50A	LDF4.5-50	LDF5-50A	LDF6-50	LDF7-50A	LDF12-50
Fire Retardant Cables							
LDF1RN-50	LDF2RN-50	LDF4RN-50A	LDF4.5RN-50	LDF5RN-50A	LDF6RN-50	LDF7RN-50A	LDF12RN-50
LDF1RN-50	LDF2RN-50	LDF4RN-50A	LDF4.5RN-50	LDF5RN-50A	LDF6RN-50	LDF7RN-50A	LDF12RN-50
LDF1RN-50	LDF2RN-50	LDF4RN-50A	LDF4.5RN-50	LDF5RN-50A	LDF6RN-50	LDF7RN-50A	LDF12RN-50
Low VSWR Cables, Specially Tested							
LDF1P-50-(**)	LDF2P-50-(**)	LDF4P-50A-(**)	LDF4.5P-50-(**)	LDF5P-50A-(**)	LDF6P-50-(**)	LDF7P-50A-(**)	LDF12P-50-(**)
Special Application Cables							
p. 590	p. 590	p. 590	-	p. 590	-	-	-
Characteristics							
15800	13500	8800	6100	5000	3300	2500	2200
12.1	15.6	40	62	91	205	315	425
86	88	88	89	89	89	88	88
3 (76)	3.75 (95)	5 (125)	8 (200)	10 (250)	15 (380)	20 (510)	24 (610)
Attenuation, dB/100 ft (dB/100 m) Standard conditions: VSWR 1.0; ambient temperature 20°C (68°F).							
0.667 (2.19)	0.563 (1.85)	0.357 (1.17)	0.254 (0.834)	0.195 (0.641)	0.135 (0.444)	0.109 (0.356)	0.091 (0.299)
1.23 (4.05)	1.04 (3.42)	0.661 (2.17)	0.473 (1.55)	0.364 (1.19)	0.254 (0.832)	0.205 (0.671)	0.173 (0.566)
2.71 (8.88)	2.29 (7.51)	1.45 (4.75)	1.05 (3.46)	0.808 (2.65)	0.571 (1.87)	0.467 (1.53)	0.400 (1.31)
4.16 (13.6)	3.52 (11.6)	2.22 (7.28)	1.64 (5.38)	1.25 (4.12)	0.897 (2.94)	0.742 (2.43)	0.644 (2.11)
6.10 (20)	5.17 (17)	3.25 (10.7)	2.44 (8.02)	1.86 (6.11)	1.35 (4.43)	1.13 (3.71)	0.994 (3.26)
11.5 (37.7)	9.79 (32.1)	6.11 (20.1)	4.76 (15.6)	-	-	-	-
15.7 (51.5)	13.4 (43.9)	-	-	-	-	-	-
Average Power Rating, kW Standard conditions: VSWR 1.0; ambient temperature 40°C (104°F); inner conductor temperature 100°C (212°F); no solar loading.							
3.32	4.14	6.46	9.57	14.1	22.0	30.9	39.8
1.79	2.24	3.49	5.14	7.56	11.7	16.4	21.0
0.818	1.02	1.59	2.31	3.41	5.22	7.18	9.06
0.533	0.663	1.04	1.48	2.19	3.32	4.52	5.64
0.363	0.451	0.710	0.996	1.48	2.21	2.96	3.65
0.193	0.239	0.378	0.511	-	-	-	-
0.141	0.175	-	-	-	-	-	-



Coaxial Cable Selection Guide



HELIAX® Coaxial Cable Selection Guide - 50-ohm, Foam and Air Dielectric

Nominal Size Catalog Pages	High Power, High Temp, Superflexible, ETS Series		High Power, High Temp, Superflexible, HST Series
	1/4"	3/8"	1/4"
	477	483	529
Standard Cables			
Fire Retardant Cables			
CATVP, UL910 PLENUM, jacketed	ETS1-50T	ETS2-50T	HST1-50
Special Application Cables			
Phase Stabilized; Phase Measured	p. 591	p. 591	-
Characteristics			
Maximum Operating Frequency, MHz	20000	13400	18000
Peak Power Rating, kW	6.4	13.2	6.4
Relative Propagation Velocity, %	82	83	82
Minimum Bend Radius, in (mm)	1 (25)	1 (25)	1 (25)
Attenuation, dB/100 ft (dB/100 m) Standard conditions: VSWR 1.0; ambient temperature 20° C (68° F).			
30 MHz	0.97 (3.19)	0.653 (2.14)	0.911 (2.99)
100 MHz	1.79 (5.86)	1.22 (3.99)	1.68 (5.51)
450 MHz	3.86 (12.7)	2.71 (8.89)	3.65 (12)
1000 MHz	5.86 (19.2)	4.22 (13.8)	5.57 (18.3)
2000 MHz	8.46 (27.7)	6.28 (20.6)	8.10 (26.6)
6000 MHz	15.4 (50.6)	12.2 (40.1)	15.0 (49.1)
10000 MHz	20.6 (67.5)	17 (55.8)	20.2 (66.2)
Average Power Rating, kW Standard conditions: VSWR 1.0; ambient temperature 40 °C (104° F); inner conductor temperature (as noted); no solar loading.			
Inner Conductor Temperature, C° (F°)	200 (392)	200 (392)	250 (482)
30 MHz	5.48	9.89	3.60
100 MHz	2.98	5.31	1.95
450 MHz	1.38	2.38	0.897
1000 MHz	0.909	1.53	0.588
2000 MHz	0.629	1.03	0.405
6000 MHz	0.345	0.529	0.219
10000 MHz	0.259	0.381	0.163

** Insert suffix number from specific cable Catalog page. † See specific Catalog page.

Coaxial Cable Selection Guide



HELIAX® Coaxial Cables

HELIAX® Coaxial Cable Selection Guide - 50-ohm, Foam and Air Dielectric

High Power, High Temp., Superflexible, HST Series		Plenum, Superflexible, HS-RP Series		
3/8"	1/2"	1/4"	3/8"	1/2"
533	549	527	531	546
Standard Cables				
Fire Retardant Cables				
HST2-50	HST4-50	HS1RP-50A	HS2RP-50	HS4RP-50
-	-	-	-	-
Special Application Cables				
-	-	-	-	-
Characteristics				
13400	10200	10000	13400	10200
13.2	15.6	6.4	13.2	15.6
83	81	84	83	81
1 (25)	1.25 (32)	1 (25)	1 (25)	1.25 (32)
Attenuation, dB/100 ft (dB/100 m) Standard conditions: VSWR 1.0; ambient temperature 20°C (68°F).				
0.667 (2.19)	0.586 (1.92)	0.941 (3.09)	0.650 (2.13)	0.512 (1.68)
1.23 (4.05)	1.09 (3.58)	1.73 (5.69)	1.20 (3.94)	0.947 (3.11)
2.70 (8.85)	2.42 (7.93)	3.75 (12.3)	2.61 (8.56)	2.07 (6.78)
4.13 (13.6)	3.74 (12.3)	5.70 (18.7)	3.98 (13.0)	3.16 (10.4)
6.04 (19.8)	5.55 (18.2)	8.24 (27.0)	5.78 (19.0)	4.62 (15.2)
11.3 (37.2)	10.7 (35.1)	15.1 (49.5)	10.7 (35.1)	8.63 (28.3)
15.4 (50.5)	14.8 (48.6)	20.2 (66.2)	14.4 (47.2)	11.7 (38.4)
Average Power Rating, kW Standard conditions: VSWR 1.0; ambient temperature 40°C (104°F); inner conductor temperature (as noted); no solar loading.				
200 (392)	200 (392)	100 (212)	100 (212)	100 (212)
9.98	15.6	1.56	2.69	3.31
5.40	9.29	0.850	1.46	1.79
2.47	4.19	0.393	0.670	0.821
1.61	2.71	0.259	0.439	0.537
1.10	1.83	0.179	0.302	0.368
0.588	0.947	0.098	0.164	0.197
0.433	0.685	0.073	0.121	0.145

** Insert suffix number from specific cable Catalog page. † See specific Catalog page.

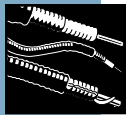

Coaxial Cable Selection Guide



HELIAX® Coaxial Cable Selection Guide - 50-ohm, Air Dielectric

Nominal Size Catalog Pages	Air Dielectric, HJ Series				
	1/2"	5/8"	7/8"	1-5/8"	2-1/4"
	535	552	555	560	563
Standard Cables					
Standard Black Jacket	HJ4-50	HJ4.5-50	HJ5-50	HJ7-50A	HJ12-50
Fire Retardant Cables					
CATVX, VW-1, IEC 332-1	HJ4RN-50	HJ4.5RN-50	HJ5RN-50	HJ7RN-50A	HJ12RN-50
CATV, UL1581, IEC 332-3, IEEE 383	HJ4RN-50	HJ4.5RN-50	HJ5RN-50	HJ7RN-50A	HJ12RN-50
CATVR, UL1666 (Riser)	HJ4RN-50	HJ4.5RN-50	HJ5RN-50	HJ7RN-50A	HJ12RN-50
CATVP, UL910 PLENUM, jacketed	41690-85	-	HJ5RP-50	HJ7RP-50A	-
Low VSWR Cables, Specially Tested					
Standard Black Jacket	HJ4P-50-(**)	HJ4.5P-50-(**)	HJ5P-50-(**)	HJ7P-50A-(**)	HJ12P-50-(**)
	-	-	-	HJ7SP-50A-(**)	-
Fire Retardant (CATVR), 824-894 MHz, 1.20 VSWR max.	-	-	41690-78	41690-79	-
Special Application Cables					
High Power/High Temperature Phase Stabilized; Phase Measured	p. 591	-	p. 591	27591-101 p. 591	-
Characteristics					
Maximum Operating Frequency, MHz	10900	6600	5200	2700	2300
Peak Power Rating, kW	21	40	90	305	425
Relative Propagation Velocity, %	91.4	92	91.6	92.1	93.1
Minimum Bend Radius, in (mm)	5 (125)	7 (180)	10 (250)	20 (510)	22 (560)
Attenuation, dB/100 ft (dB/100 m) Standard conditions: VSWR 1.0; ambient temperature 20° C (68° F).					
30 MHz	0.442 (1.45)	0.264 (0.867)	0.198 (0.651)	0.109 (0.358)	0.0906 (0.297)
100 MHz	0.821 (2.69)	0.488 (1.60)	0.369 (1.21)	0.203 (1.666)	0.169 (0.555)
450 MHz	1.82 (5.96)	1.07 (3.51)	0.823 (2.70)	0.451 (1.48)	0.378 (1.24)
1000 MHz	2.81 (9.23)	1.64 (5.37)	1.28 (4.20)	0.701 (2.30)	0.589 (1.93)
2000 MHz	4.17 (13.7)	2.40 (7.86)	1.91 (6.26)	1.04 (3.42)	0.880 (2.89)
6000 MHz	8.03 (26.3)	4.49 (14.8)	-	-	-
10000 MHz	11.1 (36.4)	-	-	-	-
Average Power Rating, kW Standard conditions: VSWR 1.0; ambient temperature 40° C (104° F); inner conductor temperature (as noted); no solar loading.					
Inner Conductor Temperature, C° (F°)	100 (212)	100 (212)	100 (212)	100 (212)	100 (212)
30 MHz	4.40	8.94	14.0	30.8	43.1
100 MHz	2.37	4.84	7.53	16.5	23.1
450 MHz	1.07	2.20	3.38	7.44	10.3
1000 MHz	0.690	1.43	2.17	4.79	6.63
2000 MHz	0.466	0.986	1.46	3.22	4.44
6000 MHz	0.242	0.525	-	-	-
10000 MHz	0.175	-	-	-	-

** Insert suffix number from specific cable Catalog page. † See specific Catalog page.

Coaxial Cable Selection Guide

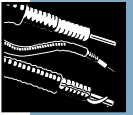

HELIX® Coaxial Cables

HELIX® Coaxial Cable Selection Guide - 50-ohm, Air Dielectric

	Air Dielectric, HJ Series			5" High Power
	3" 566	4" 568	5" 570	5" 572
Standard Cables				
	HJ8-50B	HJ11-50	HJ9-50	HJ9HP-50
Fire Retardant Cables				
	-	-	-	-
	-	-	-	-
	-	-	-	-
	-	-	-	-
Low VSWR Cables, Specially Tested				
	42141 [†]	42144 [†]	42142 [†]	-
	209227 [†]	-	-	-
	-	-	-	-
Special Application Cables				
	-	-	-	-
	-	-	-	-
Characteristics				
	1640	1220	960	960
	640	1100	1890	1690
	93.3	92	93.1	96.4
	30 (760)	40 (1015)	50 (1270)	50 (1270)
Attenuation, dB/100 ft (dB/100 m) Standard conditions: VSWR 1.0; ambient temperature 20°C (68°F).				
	0.0732 (0.240)	0.0601 (0.197)	0.0419 (0.138)	0.0381 (0.125)
	0.141 (0.464)	0.114 (0.376)	0.0789 (0.259)	0.0748 (0.245)
	0.340 (1.12)	0.268 (0.879)	0.180 (0.590)	0.186 (0.612)
	0.563 (1.85)	0.434 (1.42)	-	-
	-	-	-	-
	-	-	-	-
	-	-	-	-
Average Power Rating, kW Standard conditions: VSWR 1.0; ambient temperature 40° C (104° F); inner conductor temperature (as noted); no solar loading.				
	121 (250)	121 (250)	100 (212)	150 (302)
	81.9	123	159	335
	0.141	64.7	84.5	172
	0.340	27.6	37.1	70.8
	10.6	17.1	-	-
	-	-	-	-
	-	-	-	-
	-	-	-	-

** Insert suffix number from specific cable Catalog page. † See specific Catalog page.

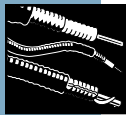

Coaxial Cable Selection Guide



HELIAX® Coaxial Cable Selection Guide - 50-ohm, Air Dielectric

Nominal Size	Air Dielectric, High Power HT Series		Air Dielectric, High Power High Temp., HLT Series	Air Dielectric, Plenum HL Series
	1/2"	7/8"	1/2"	1/2"
Catalog Pages	538	558	543	540
Standard Cables				
Standard Black Jacket	-	-	-	-
Fire Retardant Cables				
CATVX, VW-1, IEC 332-1	-	-	-	-
CATV, UL1581, IEC 332-3, IEEE 383	-	-	-	-
CATVR, UL1666 (Riser)	-	-	-	-
CATVP, UL910 PLENUM, jacketed	-	-	HLT4-50T	HL4RP-50
CATVP, UL910 PLENUM, unjacketed	HT4-50	HT5-50	-	-
Special Application Cables				
High Power/High Temperature	HT4-50	HT5-50	HLT4-50T	HL4RP-50
Characteristics				
Maximum Operating Frequency, MHz	10900	5200	4000	6000
Peak Power Rating, kW	21	90	21.4	40.0
Relative Propagation Velocity, %	92	92.5	93	88
Minimum Bend Radius, in (mm)	5 (125)	10 (250)	5 (125)	5(125)
Attenuation, dB/100 ft (dB/100 m) Standard conditions: VSWR 1.0; ambient temperature 20° C (68° F).				
30 MHz	0.468 (1.54)	0.198 (0.651)	0.377 (1.24)	0.389 (1.28)
100 MHz	0.888 (2.91)	0.369 (1.21)	0.718 (2.35)	0.725 (2.38)
450 MHz	2.06 (6.75)	0.823 (2.70)	1.67 (5.48)	1.61 (5.28)
1000 MHz	3.31 (10.9)	1.28 (4.20)	2.7 (8.85)	2.5 (8.19)
2000 MHz	5.10 (16.7)	1.91 (6.26)	4.18 (13.7)	3.71 (12.2)
6000 MHz	10.7 (35.1)	-	-	7.18 (23.6)
10000 MHz	15.5 (50.7)	-	-	-
Average Power Rating, kW Standard conditions: VSWR 1.0; ambient temperature 40° C (104° F); inner conductor temperature 100° C (212° F); no solar loading.				
Inner Conductor Temperature, C° (F°)	200 (392)	200 (392)	200 (392)	100 (212)
30 MHz	11.8	32.7	12.7	6.78
100 MHz	6.21	16.6	6.70	3.64
450 MHz	2.68	6.65	2.88	1.64
1000 MHz	1.67	3.92	1.78	1.06
2000 MHz	1.08	1.51	1.15	0.713
6000 MHz	0.516	-	-	0.368
10000 MHz	0.357	-	-	-

Coaxial Cable Selection Guide



HELIAX® Coaxial Cables

HELIAX® Coaxial Cable Selection Guide - 75-ohm, Foam and Air Dielectric

Superflexible, FSJ Series		Foam Dielectric, LDF Series		Air Dielectric, HJ Series
1/4"	1/2"	1/2"	7/8"	7/8"
574	576	578	580	582
Standard Cables				
FSJ1-75	FSJ4-75A	LDF4-75A	LDF5-75	HJ5-75
Fire Retardant Cables				
FSJ1RN-75A	FSJ4RN-75A	LDF4RN-75A	–	HJ5RN-75
FSJ1RN-75A	FSJ4RN-75A	LDF4RN-75A	–	HJ5RN-75
FSJ1RN-75A	FSJ4RN-75A	LDF4RN-75A	–	HJ5RN-75
–	–	–	–	–
–	–	–	–	–
Special Application Cables				
–	–	–	–	–
Characteristics				
22000	11500	10000	5300	5600
6.7	10.0	26	70	60
78	81	88	89	90
1 (25)	1.25 (32)	5 (125)	10 (250)	10 (250)
Attenuation, dB/100 ft (dB/100 m) Standard conditions: VSWR 1.0; ambient temperature 20° C (68° F).				
0.999 (3.28)	0.514 (1.68)	0.333 (1.09)	0.195 (0.639)	0.209 (0.686)
1.86 (6.12)	0.958 (3.14)	0.618 (2.03)	0.366 (1.2)	0.388 (1.27)
4.17 (13.7)	2.14 (7.02)	1.37 (4.5)	0.834 (2.74)	0.850 (2.79)
6.51 (21.4)	3.34 (11)	2.12 (6.97)	1.32 (4.34)	1.29 (4.23)
9.73 (31.9)	4.98 (16.4)	3.15 (10.3)	2.01 (6.6)	1.92 (6.30)
19.1 (62.7)	9.78 (32.1)	6.09 (20)	–	–
26.7 (87.6)	13.6 (44.7)	8.42 (27.6)	–	–
Average Power Rating, kW Standard conditions: VSWR 1.0; ambient temperature 40° C (104° F); inner conductor temperature 100° C (212° F); no solar loading.				
100 (212)	100 (212)	100 (212)	100 (212)	100 (212)
1.06	3.30	3.10	5.65	9.31
0.570	1.77	1.67	3.00	5.01
0.255	0.794	0.753	1.32	2.25
0.163	0.509	0.486	0.832	1.49
0.109	0.341	0.328	0.548	0.977
0.056	0.174	0.170	–	–
0.040	0.125	0.123	–	–

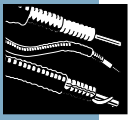

HELIAX® Coaxial Cable *Accept No Substitute*

HELIAX® Coaxial Cables



Service Guarantee

At Andrew, we're committed to exceeding our customers' highest expectations by offering the best products backed by the most responsive service in the industry. So whatever our customers need, whenever and wherever they need it, we will deliver.

HELIAX® is the Andrew brand name that stands for the most complete, cost-effective, high performance coaxial cable systems in the world.

For more than 40 years, Andrew Corporation has led the industry in meeting the need for semi-flexible RF transmission line. In land mobile, broadcast, cellular, military, terrestrial microwave, HF, earth station, personal communication, and many other applications, HELIAX coaxial cable products, including air and foam-dielectric cable, are the industry standard of excellence. The unique feature that makes HELIAX coaxial cable the best in the world is a solid copper, corrugated outer conductor which gives it strength, durability, flexibility, and complete shielding. These outstanding coaxial cables are complemented by our compatible connectors, hangers, grounding systems and other installation accessories to form a complete RF transmission line system. This broad range of coaxial cable and cable products means that Andrew can provide the right fit for any application you may have, from a single component to a complete, integrated cable system. It also means that all of your transmission line needs can be met by just one vendor — Andrew.

When you purchase HELIAX coaxial cable from Andrew, you're buying more than just cable. You're buying quality and performance that will save you money over the life of your system investment. You receive:

- *Outstanding Electrical Performance*
- *Long Service Life*
- *Simplified System Planning*
- *Lower Installation Cost*
- *ISO 9001 Certified*

Here's a closer look at the benefits:

Outstanding Electrical Performance

HELIAX coaxial cable, connectors and accessories are designed to provide optimum electrical performance for a wide range of RF applications. You can be certain that HELIAX coaxial cable systems will perform as you expect with no surprises.

HELIAX connectors are designed exclusively for use with HELIAX coaxial cables to provide excellent electrical performance for the complete transmission line system.

Low Attenuation

The low attenuation of HELIAX coaxial cable results in highly efficient signal transfer which maximizes overall system performance.

Complete Shielding

Because HELIAX cable has a solid copper outer conductor, you get continuous RFI/EMI shielding to minimize interference and maximize system security.

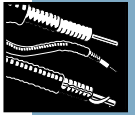

Low VSWR

HELIAX feeder cables, LDF4 - LDF7 and VXL series cables, now feature a maximum VSWR of 1.13:1 in the cellular and PCS bands. This specification applies to bulk length cable and includes straight DIN or N-type connectors.

Also available are lower VSWR options, or low VSWR in other frequency bands. Refer to the Low VSWR Specifications tables for each cable type.

Excellent Intermodulation Performance

The solid inner and outer conductors of HELIAX cable virtually eliminate intermodulation generation. Connectors minimize intermodulation by ensuring high contact pressure at the connector to cable interface.

High Power Rating

The low attenuation and excellent heat transfer properties of HELIAX cables combined with temperature stabilized dielectric materials result in safe long term operation at the high average power levels often required for broadcast, military and other transmit applications.

Long Service Life

When it comes to reliability, HELIAX coaxial cables have built-in quality features to protect your investment and provide long term cost-effective performance. Service and maintenance costs are avoided because HELIAX cable systems are designed to last.

All HELIAX coaxial cables are jacketed for direct burial or for corrosive environmental conditions. Standard jacketing material is weather-resistant polyethylene suitable for use in extreme climates. Operational fire retardant CATVX, CATVR and CATVP rated jacketed cables are available to meet safety regulations for indoor installations. The fire retardant cables are UV stabilized and do not require additional UV protection during outdoor storage. See page 631 for information on cable and connector temperature ratings.

Strong and Flexible

HELIAX cable's solid copper, corrugated outer conductor gives it great strength, durability and flexibility. This assures long life as well as ease of installation.

Weatherproof and Durable

HELIAX cable's standard black polyethylene jacketing is weatherproof and ultraviolet stabilized making it suitable for outdoor applications. HELIAX cable is directly buriable and highly resistant to crushing. It is exceptionally corrosion resistant, helping to provide a long term, trouble-free cable system. Many users have been in operation for more than 20 years with the same HELIAX cable.



HELIAX® is the registered trademark under which semi-flexible coaxial cables are sold by Andrew. HELIAX cables, connectors and accessories are proprietary products of Andrew manufactured under patents issued and pending.

Reliable

The availability of HELIAX cable in long, continuous lengths eliminates the need for joints which can affect reliability.

Simplified System Planning

Selecting a HELIAX cable system will make system planning easy and cost-effective. With Andrew, you have the advantage of our outstanding engineering resources and comprehensive product line. Look at the system planning benefits you receive when you purchase HELIAX coaxial cable:

One-Stop Shopping

With Andrew "one-stop" shopping, all of your transmission line needs – quality cable, connectors, accessories and service – are available from one vendor. You avoid the problems of delivery delays, out-of-sequence deliveries, and non-compliant materials which are frequently the result of dealing with multiple vendors. At Andrew, all of our cable components are engineered to work together as a HELIAX cable system.

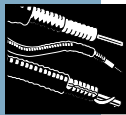

HELIAX® Coaxial Cable

Accept No Substitute

HELIAX® Coaxial Cables



Fast Delivery

Product availability is critical when you have a weather emergency or last minute design change that could result in downtime and lost revenue. In such situations, we respond quickly to get you on-the-air. Rapid product availability allows Andrew to be a real problem solver for you at installation time. With schedules to meet, you need to avoid delivery delays, contain costs, and get your system operating on time. With HELIAX coaxial cable from Andrew, you can do it.

Large Variety of Sizes and Types

The wide variety of HELIAX cable sizes and types lets you select the best cable for your specific application allowing more cost-effective planning. Optional fire-retardant, non-halogenated jacketing is available to meet safety regulations for indoor installations.

See Cable Selection Guide on pages 442 - 449.

Factory Connector Attachment

For your convenience, HELIAX cables can be ordered cut to length and factory fitted with connectors per your specifications. This service helps you avoid field assembly and testing.

Free Software and Product Information

To help plan your system, Andrew provides a number of helpful software packages. In addition, you can obtain Installation Instruction Bulletins, Special Publications and Product Specifications via Fax-On-Demand and the Andrew web site.

Snap-Clean Foam Dielectric

Snap-Clean foam dielectric sets a new standard for quick, easy connector installation. With a simple twist, the foam dielectric snaps free of the inner conductor, leaving the solid inner conductor ready for connector attachment with no foam or adhesive residue. Additional cleaning and scraping of the cable are not required. This saves time, money and results in superior electrical performance of the cable and connector. Snap-Clean is featured on HELIAX foam cables with a solid inner conductor.

Lower Installation Cost

The HELIAX cable product line helps lower your field installation costs.

Long Continuous Lengths

This simplifies installation and eliminates the cost of splicing. Cable lengths can be conveniently stocked on site and cut to required lengths.

Flexibility

HELIAX cable's corrugated copper outer conductor gives it flexibility which makes shipping, handling and installation easier and more cost-effective than rigid line.

Ease of Connector Attachment

Connectors for HELIAX coaxial cable can be easily attached in the field with standard hand tools. HELIAX connectors provide high resistance to connector pull-off and twist-off as well as excellent electrical contact.

Whatever your transmission line needs may be, HELIAX coaxial cables, connectors and accessories made exclusively by Andrew consistently provide you with outstanding electrical performance, long service life, simplified system planning, and lower installation costs.

ISO 9001 Certified

ISO 9001 is the internationally recognized standard for quality systems. It was designed to provide a thorough, yet flexible model for quality systems design and implementation. Andrew facilities have successfully completed the requirements of ISO 9001, the most stringent portion of the standard. This certification resulted from a consistent quality system that involves everyone in the organization in improving both internal and external quality.

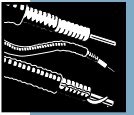

HELIAX® Coaxial Cable Types

Foam dielectric (LDF Series)

Flexible Feeder (VXL Series)

Superflexible foam dielectric (FSJ and ETS Series)

Extraflexible foam dielectric (EFX Series)

Superflexible star dielectric (HS and HST Series)

Air dielectric (HL, HT and HJ Series)

HELIAX® Coaxial Cables

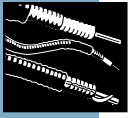

Superflexible and Extraflexible Cables



Superflexible and Extraflexible Cables

HELIAX® superflexible and extraflexible cables are designed for ease of installation in tight wiring spaces in shelters, radio rooms, and plenums. These cables are perfect for antenna and equipment room jumpers. Like all HELIAX cables, superflexible cables feature a solid outer conductor for unsurpassed electrical and mechanical performance. A polyethylene foam dielectric offers excellent electrical performance and prevents water migration.

Flexibility

Andrew HELIAX superflexible cables are manufactured with deep, helical corrugations in the outer conductor. Extraflexible cables are manufactured with deep, annular corrugations. These exclusive corrugating processes permit Andrew cables and assemblies to be bent on very tight radii, without any degradation in performance. In addition, numerous reverse bends can be made, again without loss in performance.

Superior Electrical Performance

HELIAX cables and assemblies offer specifiers and users superior electrical performance in smaller sized cables. HELIAX cables and assemblies provide excellent attenuation and superior power handling and shielding versus comparably sized braided cables.

Excellent Intermodulation Performance

The solid inner and outer conductors found in all HELIAX cables minimize intermodulation generation. The braided outer conductors and stranded inner conductors that are

common in other cables form numerous contacts in the electrical path, which are sources of intermodulation.

Complete Product Range

Andrew now offers a complete range of cables to meet every application and budget requirement. HELIAX superflexible and extraflexible cables are available in a wide range of sizes and constructions for general use, plenum, and flame retardant applications. The HS series cables feature a star-shaped dielectric and superflexible construction. They are for use in plenum applications. The HST superflexible cables are for high power applications. These new cables feature a star-shaped dielectric which offers higher power handling at higher temperatures than any other flexible cable. A wide selection of connectors and factory manufactured assemblies in both standard and custom jumper configurations is available, to complement Andrew cable and make system planning easy and simple.

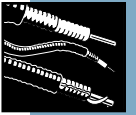

New VXL Series of Flexible Feeder Cables

HELIAX® flexible feeder cables are designed for use in difficult areas. They are more flexible than LDF series, while maintaining similar attenuation characteristics. 7/8" VXL5-50 is suitable for use as a one-piece feeder line from radio equipment to antenna, thus eliminating the need for jumper cables.



Superior Performance

New VXL series flexible feeder cable uses advanced processing technology to provide a lower cost/higher performance solution that is ideal for wireless applications. System designers and engineers can eliminate the need for jumper cables when VXL5-50, a 7/8" feeder cable, is specified. It is suitable for continuous cable runs from the base station cabinet to the antenna. When used as one-piece feeder line, VXL5-50 requires no jumper cable from feeder to antenna. This eliminates extra connectors, lowering insertion loss, and minimizing installation time. Versatile and flexible, VXL series cable is also suitable for installation in difficult areas such as lift shafts, monopoles, and co-located sites.

Lower Site Costs

VXL5, VXL6, and VXL7 cables are lighter weight than standard series cables. The cable's reduced weight and tighter bending radius minimize installation time and lower site costs. Jumper cables are not required with

VXL5-50. This means fewer connectors, less weather-proofing, and lower costs. The lighter weight of VXL series cable also reduces shipping costs.

Outstanding Electrical Performance

All VXL series cables have a closed-cell, foam polyethylene dielectric that prevents water migration and maintains its characteristics over time. The low-density foam provides low attenuation characteristics similar to LDF series cables. When used as a combined feeder/jumper solution, both system attenuation and system VSWR are optimized.

Flexibility

The VXL5 cable exhibits the tight bend radius of a 1/2" jumper. It, therefore, requires no jumpers when used as a main feeder. When the cable is used as a stand-alone jumper, it is the lowest-loss jumper solution in the industry.

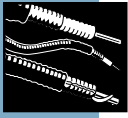

LDF Series Foam Dielectric Cables

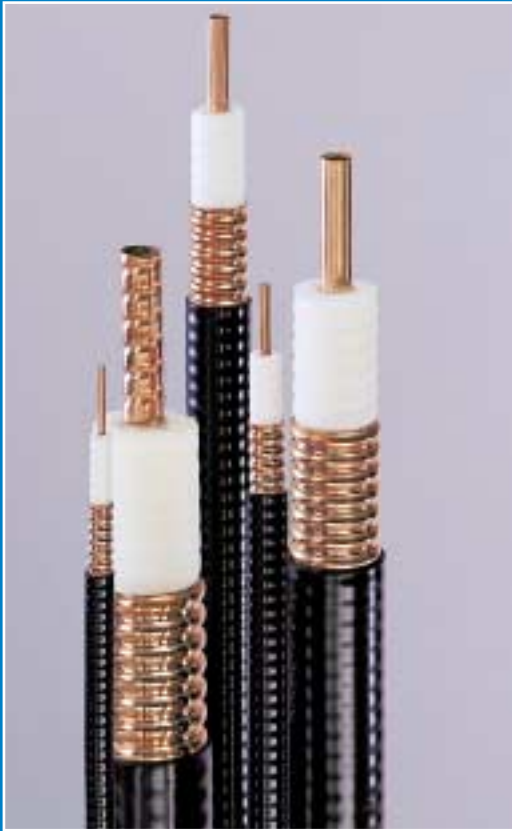

Foam Dielectric Cables

Superior Electrical Performance

Like the FSJ and EFX cables, LDF cables have a closed-cell, foam-polyethylene dielectric that prevents water migration and maintains its characteristics over time.

LDF cables are designed for low loss. Their lower density foam allows higher velocities and provides lower attenuation than FSJ cables. Attenuation characteristics approach those of air dielectric cables.

Flexibility

HELIAX foam dielectric cables feature an annularly corrugated outer conductor that provides excellent shielding while offering flexibility.

Complete Product Range

LDF cables are available in sizes from 1/4" to 2-1/4" to meet application requirements for cellular and personal communications, land mobile radio, earth station antenna jumpers, equipment room and antenna jumpers, CATV, HF communications, VLF, military data links, AM and FM broadcast, terrestrial microwave, and CCTV. Phase stabilized versions are available.

Weatherproof

Closed cell dielectric prevents water penetration. Connector O-rings seal out moisture.

Excellent Intermodulation Performance

Solid inner and outer conductors eliminate IM generated by numerous moving contacts in the current path that are found with stranded inner conductors and braided outer conductors.

Quick and Easy Connector Attachment

A range of self flaring connectors are available for easy field attachment requiring no special tools.

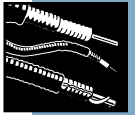

Air Dielectric Cables

HELIAX[®] air dielectric cables from Andrew, available in 1/4" to 5" sizes, are designed to give you the lowest attenuation and highest average power rating. When these cables are equipped with the proper pressurization systems, they may be used in any indoor/outdoor environment. Air cables, if used indoors in a controlled environment, do not require pressurization.

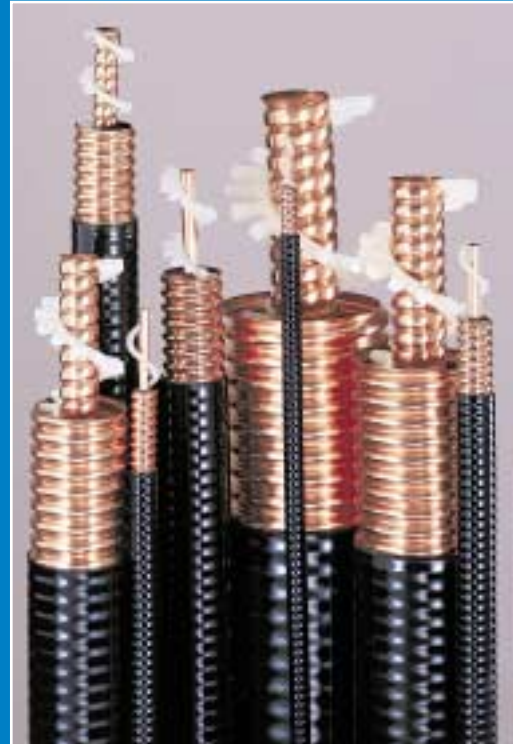

HELIAX[®] Coaxial Cables

The HJ air cables have a polyethylene or polypropylene spacer, and different jacketing materials dependent on fire retardancy requirements. High power HJ series cables use a special fluoropolymer spacer for maximum power handling with excellent attenuation. The cables are ideal for antenna feeder applications such as AM and FM radio, UHF and VHF TV, terrestrial microwave and earth station antenna systems, land mobile and cellular radio, ITFS, MMDS and MDS antenna systems, HF communications, military communications and radar.

The HL air cables utilize a polyethylene spiral to space the inner conductor from the outer conductor, and a fluoropolymer jacket to provide fire retardancy. These cables are intended for indoor plenum type applications.

The HT air cables use a fluoropolymer spiral to space the inner from the outer, and are unjacketed. These cables are for high temperature and/or high power applications.

The Outstanding Features of HELIAX[®] Air-Dielectric Cables are:

Low Attenuation

Low loss dielectric materials combined with high conductivity copper conductors result in low attenuation for efficient signal transfer and maximum system performance.

Solid Copper Corrugated Outer Conductor

Results in low loss, continuous RFI/EMI shielding to minimize interference and maximize system security. Corrugated outer conductor allows for ease of installation.

High Power Handling

Results from low attenuation and excellent heat transfer characteristics.

Weatherproof/Pressure Tight

HJ type cables have silicone gasketed connectors with 1/8" NPT pressure inlets. Connectors are designed to be pressure tight for maximum protection against water entry.

System Integrity

If a pressurized air-dielectric cable should be damaged, the pressurization system will alarm so that the leak can be corrected before water enters the cable and degrades performance.

Rugged Construction

HELIAX HJ cables are made with the strongest dielectric spacer in the industry, to withstand the stress of installation.

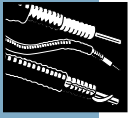

HELIAX® Cables and Connectors Now with Ten Year Warranty

An extended ten-year warranty is now included, at no extra charge, on all new purchases of HELIAX coaxial cable, connectors and cable assemblies. Here are the details of this exclusive warranty:

- Complete coverage against defects in material and workmanship for HELIAX cables, connectors and assemblies.
- When connectors are attached by Andrew or an Andrew certified distributor, the attachment is also covered.
- Any HELIAX coaxial cable that has been fitted with non-Andrew connectors is expressly excluded from this extended warranty and is subject to the terms of the Andrew standard one-year warranty.



HELIAX® Coaxial Cable...

Today's Alternative to Braided Cable

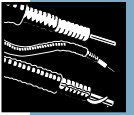

HELIAX® Coaxial Cables

Excellent Intermodulation Performance

HELIAX coaxial cables and connectors minimize intermodulation generation by using solid conductors. Stranded inner conductors and braided outer conductors, used in many other cables, form numerous contacts within the current path which are a source of intermodulation.

Complete RF Shielding

Unlike braided cables, HELIAX coaxial cables have a solid corrugated copper outer conductor to protect against electromagnetic interference and radio frequency interference (EMI and RFI).

Phase Stability

HELIAX coaxial cables offer excellent phase stability over temperature variations and with bending. This makes them an excellent choice for phase-critical applications such as delay lines and matched feeders in phased-array antennas.

Low Attenuation

The continuous outer conductor and low loss polyethylene foam dielectric of HELIAX cables result in much lower losses than comparably sized braided cables.

High Power Capability

The excellent thermal conductivity and the low attenuation of HELIAX cables provide for higher average power handling capability when compared to comparably sized braided cables.

Flexibility

HELIAX coaxial cables have excellent flexibility for ease of installation. These cables can be bent on small radii and will withstand repeated bends without degrading performance.

Weatherproof and Durable for Outdoor Applications

HELIAX coaxial cables are protected with a rugged black polyethylene jacket which provides abrasion resistance and complete environmental protection. Unlike braided cables, they can be used outdoors without the fear of water migration.

Fire Retardancy

HELIAX coaxial cables are available with special jacketing to meet relevant fire retardance standards. See page 626.



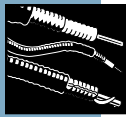

HELIAX® Coaxial Cable vs Conventional Braided Cables*

HELIAX® Coaxial Cables

HELIAX Coaxial Cables										
	Standard Superflexible			Extraflexible	LDF Series			Plenum Rated		
Nominal Size	FSJ1-50A	FSJ2-50	FSJ4-50B	EFX2-50	LDF1-50	LDF2-50	LDF4-50A	HS1RP-50	HS2RP-50	HS4RP-50
Impedance, ohms	50	50	50	50	50	50	50	50	50	50
Electrical Characteristics										
Relative Propagation Velocity, %	84	83	81	85	86	88	88	84	83	81
Maximum Operating Frequency, MHz	20400	13400	10200	13500	15800	13500	8800	10000	13400	10200
Attenuation, dB/100 ft (dB/100 m) Standard conditions: VSWR 1.0; ambient temperature 20° C (68° F).										
150 MHz	2.21 (7.25)	1.48 (4.86)	1.28 (4.21)	1.34 (4.39)	1.52 (4.99)	1.29 (4.24)	0.815 (2.67)	2.13 (6.99)	1.48 (4.84)	1.17 (3.83)
450 MHz	3.91 (12.8)	2.64 (8.66)	2.31 (7.59)	2.39 (7.83)	2.71 (8.88)	2.29 (7.51)	1.45 (4.75)	3.75 (12.3)	2.61 (8.56)	2.07 (6.78)
824 MHz	5.38 (17.6)	3.66 (12.0)	3.23 (10.6)	3.31 (10.8)	3.74 (12.3)	3.17 (10.4)	2.00 (6.56)	5.14 (16.9)	3.59 (11.8)	2.85 (9.35)
960 MHz	5.38 (19.1)	3.97 (13.0)	3.52 (11.6)	3.59 (11.8)	4.07 (13.3)	3.44 (11.3)	2.17 (7.12)	5.58 (18.3)	3.89 (12.8)	3.09 (10.2)
1500 MHz	7.41 (24.3)	5.08 (16.7)	4.54 (14.9)	4.60 (15.1)	5.19 (17.0)	4.40 (14.4)	2.77 (9.09)	7.06 (23.2)	4.94 (16.2)	3.94 (12.9)
2000 MHz	8.67 (28.5)	5.97 (19.6)	5.37 (17.6)	5.41 (17.8)	6.1 (20)	5.17 (17)	3.25 (10.7)	8.24 (27.0)	5.78 (19.0)	4.62 (15.2)
4000 MHz	12.8 (41.8)	8.90 (29.2)	8.15 (26.7)	8.08 (26.5)	9.06 (29.7)	7.70 (25.3)	4.82 (15.8)	12.0 (39.5)	8.49 (27.8)	6.8 (22.4)
6000 MHz	16.1 (52.7)	11.3 (37.2)	10.5 (34.4)	10.3 (33.8)	11.5 (37.7)	9.79 (32.1)	6.11 (20.1)	15.1 (49.5)	10.7 (35.1)	8.63 (28.3)
10000 MHz	21.7 (71.2)	15.5 (50.8)	14.6 (47.9)	14.1 (46.3)	15.7 (51.5)	13.4 (43.9)	- -	20.2 (66.2)	14.4 (47.2)	11. (38.4)
Average Power Rating, kW Standard conditions: VSWR 1.0; ambient temperature 40° C (104° F); inner conductor temperature 100° C (212° F), except HST Series 200° C (392° F).										
150 MHz	1.00	1.74	2.49	1.74	1.45	1.81	2.83	0.691	1.18	1.46
450 MHz	0.567	0.975	1.38	0.978	0.818	1.02	1.59	0.393	0.670	0.821
824 MHz	0.412	0.704	0.991	0.706	0.592	0.736	1.15	0.286	0.487	0.595
960 MHz	0.380	0.648	0.909	0.649	0.545	0.678	1.06	0.264	0.449	0.549
1500 MHz	0.299	0.507	0.705	0.507	0.426	0.530	0.833	0.209	0.354	0.431
2000 MHz	0.256	0.431	0.597	0.431	0.363	0.451	0.710	0.179	0.302	0.368
4000 MHz	0.174	0.289	0.394	0.289	0.245	0.303	0.479	0.123	0.206	0.249
6000 MHz	0.138	0.228	0.306	0.227	0.193	0.239	0.378	0.098	0.164	0.197
10000 MHz	0.102	0.166	0.220	0.165	0.141	0.175	-	0.073	0.121	0.145
Mechanical Characteristics										
Diameter over jacket										
in (mm)	0.29 (7.4)	0.415 (10.5)	0.52 (13.2)	0.45 (11.3)	0.345 (8.8)	0.44 (11.2)	0.63 (15.9)	0.29 (7.37)	0.415 (10.5)	0.518 (13.16)
Weight										
lb/ft (kg/m)	0.045 (0.067)	0.078 (0.12)	0.14 (0.21)	0.09 (0.13)	0.06 (0.09)	0.08 (0.12)	0.15 (0.22)	0.063 (0.093)	0.076 (0.113)	0.138 (0.205)
Min. Bending Radius										
in (mm)	1 (25)	1 (25)	1.25 (32)	1.75 (45)	3 (76)	3.75 (95)	5 (125)	1 (25)	1 (25)	1.25 (32)



Conventional Braided Cables

Standard Superflexible			Conventional Braided Cables						
FSJ1-75	FSJ4-75A	LDF Series LDF4-75A	M17/74	M17/75	Commercial	M17/60	M17/127	M17/2	M17/6
1/4"	1/2"	1/2"	RG-213/U	RG-214/U	Version of	RG-142B/U	RG-393/U	RG-6/U	RG-11/U
75	75	75			RG-213/U				
78	81	88	65.9	65.9	84	69.5	69.5	65.9	65.9
22000	11500	10000	1000	11000	-	12400	11000	300	1000
2.31 (7.57)	1.19 (3.89)	0.764 (2.51)	2.6 (8.5)	2.9 (9.5)	1.5 (4.9)	4.6 (15.1)	2.7 (8.8)	3.6 (11.8)	2.7 (8.8)
4.17 (13.7)	2.14 (7.02)	1.37 (4.50)	5.0 (16.4)	5.5 (18.0)	2.8 (9.2)	8.4 (27.6)	4.9 (16.1)	6.7 (22.0)	5.1 (16.7)
5.83 (19.1)	2.99 (9.82)	1.91 (6.26)	7.4 (24.3)	7.8 (25.6)	4.0 (13.1)	11.8 (38.7)	7.0 (23.0)	9.6 (31.5)	7.5 (24.6)
6.36 (20.9)	3.26 (10.7)	2.08 (6.81)	8.5 (27.9)	8.6 (28.2)	4.4 (14.4)	13.0 (42.7)	7.6 (24.9)	10.6 (34.8)	8.6 (28.2)
8.22 (27.0)	4.21 (13.8)	2.67 (8.76)	-	11.3 (37.1)	5.8 (19.0)	16.9 (55.4)	10.0 (32.8)	14.0 (45.9)	-
9.73 (31.9)	4.98 (16.4)	3.15 (10.3)	-	13.6 (44.6)	7.0 (23.0)	20.2 (66.3)	11.9 (39.0)	16.9 (55.4)	-
14.8 (48.6)	7.58 (24.9)	4.75 (15.6)	-	21.6 (70.9)	11.1 (36.4)	31.4 (103)	18.5 (60.7)	-	-
19.1 (62.7)	9.78 (32.1)	6.09 (20.0)	-	28.6 (93.8)	14.7 (48.2)	41.1 (135)	24.2 (79.4)	-	-
26.7 (87.6)	13.6 (44.7)	8.42 (27.6)	-	41.4 (136)	-	58.5 (192)	34.5 (113)	-	-
0.460	1.43	1.35	0.91	0.91	1.2	2.1	5.4	0.42	0.57
0.255	0.794	0.753	0.44	0.44	0.58	1.1	2.9	0.19	0.26
0.182	0.568	0.541	0.29	0.29	0.39	0.79	2.0	0.13	0.17
0.167	0.521	0.497	0.26	0.26	0.35	0.73	1.8	0.11	0.15
0.129	0.403	0.387	-	0.19	0.26	0.56	1.4	0.083	-
0.109	0.341	0.328	-	0.16	0.21	0.47	1.2	0.068	-
0.072	0.224	0.218	-	0.096	0.12	0.29	0.76	-	-
0.056	0.174	0.170	-	0.070	0.088	0.22	0.58	-	-
0.040	0.125	0.123	-	0.046	-	0.14	0.40	-	-
0.29 (7.4)	0.52 (13.2)	0.63 (16)	0.405 (10.29)	0.425 (10.79)	0.405 (10.29)	0.195 (4.95)	0.390 (9.91)	0.332 (8.43)	0.405 (10.29)
0.046 (0.068)	0.14 (0.21)	0.14 (0.21)	0.11 (0.164)	0.13 (0.193)	0.089 (0.132)	0.043 (0.064)	0.175 (0.260)	0.082 (0.122)	0.098 (0.146)
1 (25)	1.25 (32)	5 (125)	5 (125)	6 (150)	6 (150)	2 (50)	4 (102)	3 (75)	4.5 (115)

* Braided cables not supplied by Andrew. Listing is for comparative purposes only.

HELIAX® Connectors



Premium Performance Connectors Complement HeliAX Coaxial Cables

Andrew offers an extensive line of connectors for HeliAX coaxial cables. Used together, HeliAX cables and connectors produce the highest quality transmission line available. HeliAX connectors are designed and manufactured by Andrew. Using HeliAX cable and connectors ensures exceptional electrical and mechanical performance. Only HeliAX connectors are designed to be completely compatible with HeliAX cable. With many interfaces and attachment styles available, you can be sure you will get the characteristics you want and the performance you can rely on.



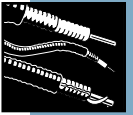

HELIAX Connectors Offer Multiple Design Advantages

Easy Attachment

HELIAX connectors are designed for fast, accurate installation. Features like pre-set pin depths and self-flaring mechanisms ensure performance and reduce costly installation errors. The connectors can be attached with the most basic hand tools. Attachment time can be reduced, even further, with EASIAx® cable preparation tools. Each connector is shipped with easy to read instructions to assist with installation.

Weatherproof Integrity

HELIAX connectors are designed to ensure system integrity in the harshest of outdoor environments. Our connectors are relied on around the world for their ability to withstand heat, humidity, ice, and rain. We design to the toughest environmental standards, such as IP68, to ensure the connectors are waterproof without additional weatherproofing. We test before and after thermal cycling, shock, and vibration testing. We guarantee that, whatever the environment, you can rely on HELIAX connectors.

Low Intermodulation

HELIAX connectors are designed to keep unwanted intermodulation to a minimum. Andrew is one of a few companies, worldwide, that understands and has the ability to measure intermodulation accurately. Couple this with engineers skilled in minimizing intermodulation and you get connectors with some of the lowest recorded intermodulation levels in the industry. For a more detailed explanation of intermodulation see page 630.

Low VSWR

HELIAX connectors give you unrivalled VSWR performance. They are designed for a minimum mismatch between cable and connector. This is especially important in today's systems where performance expectations are more stringent.

Electrical, mechanical, and environmental testing of all HELIAX connectors ensure lasting performance that can be measured in decades. Data sheets are available on request for all HELIAX connectors.

Excellent RF Shielding

Outer conductor attachments clamp or solder 360° around the cable resulting in virtually complete shielding.

HELIAX connectors for air dielectric cables are not interchangeable with those for foam dielectric cables. HS and HST series cables use corresponding FSJ connectors.

Differences include:

- *Air dielectric connectors are equipped with gas ports to allow pressurization of the cable.*
- *Most air dielectric connectors are available in both gas barrier and gas pass versions. The gas barrier prevents air flow to the mating connector.*
- *Air dielectric cables have a helical corrugated outer conductor. LDF foam cables have annular corrugations and thus use a different clamping nut to secure the connector to the cable.*
- *Most air dielectric connectors are attached using a snip flare. LDF foam connectors are self flaring.*

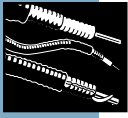

HELIAX® Connectors

OnePiece™



New OnePiece™ Connectors

- *Installation is fast and reliable*
- *Performance is excellent and dependable*
- *Connectors are completely tested and proven*

New one-piece connectors speed installation, insure attachment consistency, and provide unparalleled protection for your transmission line and system.

Speed and Reliability

With the combination of the EASIAx® Plus automated prep tools and one-piece connectors, attaching connectors to transmission lines couldn't be easier or more reliable.

The automated prep tool consistently and completely prepares the cable for connector attachment in less than 15 seconds.

With only one piece to the connector, attachment is as easy as sliding the connector on the cable and tightening the back nut. You can be assured that field attachment is consistent and gives you outstanding performance every time!

More importantly, the new one-piece connectors also have outstanding electrical characteristics!

Completely Waterproof, Mated and Unmated

The new one-piece connector is not only waterproof when mated, it is also waterproof when it is *unmated* and completely submerged in water. This moisture seal provides unparalleled protection from the elements! Exceeds IP66 and IP68 Standards.

New Version 2 Connectors for FSJ4-50B

The newest connectors for FSJ4-50B have a reduced number of components and incorporate our new "crush-flare" technology. Installation is fast, reliable, and dependable. EASIAx Plus automated cable prep tools are also available for the new version 2 connectors.

New SureFlex™ Connectors

New SureFlex jumper assemblies incorporate a 360 degree solder attachment on both the inner conductor and the outer conductor. Factory made assemblies remove the risks sometimes encountered with assemblies made in the field. Return loss, insertion loss and intermodulation values are optimized with our new SureFlex assemblies.

Proven

All Andrew components go through a strict qualification process to the toughest Military and International standards before being released. Test procedures are available on the Andrew web site or contact Andrew.

In all ways electrically, mechanically, and environmentally you can be sure with Andrew.

Value

All of the new designs offer price savings as well as outstanding performance.

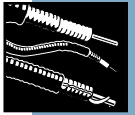

Connector Numbering System

This catalog features a functional, connector type numbering system that installation, purchasing and receiving personnel should find easy to understand. Here are three examples and the functional type number cable, connector, and suffix keys.

Type Number: **L2PNM**

L2 denotes it is used with LDF2-50 cable
PNM denotes it is a plated N Male

Type Number: **L4PNF**

L4 denotes it is used with LDF4-50 cable
PNF denotes it is a Plated N Female

Type Number: **F4PDM-C**

F4 denotes it is used with FSJ4-50B cable
PDM denotes it is a Plated 7-16 DIN Male
C denotes it features a captivated pin

Cable Keys

E2	EFX2-50	3/8"
F1	FSJ1-50A	1/4"
F2	FSJ2-50	3/8"
F4	FSJ4-50B	1/2"
H4	HJ4-50	1/2"
H4.5	HJ4.5-50	5/8"
H5	HJ5-50	7/8"
H7	HJ7-50A	1-5/8"
H8	HJ8-50B	3"
H11	HJ11-50	4"
H9	HJ9-50	5"
H9HP	HJ9HP-50	5" (High Power)
H12	HJ12-50	2-1/4"
L1	LDF1-50	1/4"
L2	LDF2-50	3/8"
L4	LDF4-50A	1/2"
L4.5	LDF4.5-50	5/8"
L5	LDF5-50A	7/8"
L6	LDF6-50	1-1/4"
L7	LDF7-50A	1-5/8"
L12	LDF12-50	2-1/4"
V5	VXL5-50	7/8"
V6	VXL6-50	1-1/4"
V7	VXL7-50	1-5/8"

Connector Keys

PNM	Plated N Male
PNR	Plated N Male Right Angle
PNF	Plated N Female
PBM	Plated BNC Male
PSM	Plated SMA Male
PSF	Plated SMA Female
PSR	Plated SMA Male Right Angle
PDM	Plated 7-16 DIN Male

Connector Keys (Continued)

PDF	Plated 7-16 DIN Female
PDR	Plated 7-16 DIN Male Right Angle
PKM	Plated 4.1-9.5 DIN Male
PKR	Plated 4.1-9.5 DIN Male Right Angle
PTM	Plated TNC Male
PTF	Plated TNC Female
SM	SMA Male
SF	SMA Female
UM	UHF Male
UF	UHF Female
MU	Mini UHF Male
FM	CATV F Male
M	EIA Flange Male
F	EIA Flange Female

Suffix Keys

HF	High Frequency
BH	Bulkhead
7550	75-Ohm Cable, 50-Ohm Mating Pin
7570	75-Ohm Cable, 70-Ohm Mating Pin
C	Captivated Pin Inner Attachment (solderless)
PM	Panel Mount
PMC	Panel Mount, Captivated Pin
H	Hex Coupling Nut
BHC	Bulkhead, Captivated Pin
PMC	Panel Mount, Captivated Pin
T	Tunable
HC	Hex Coupling Nut, Captivated Pin Inner Contact Attachment
PR	Pressure Port
RC	Ring Flare, Captivated Pin Inner contact Attachment
RPC	One-Piece Connector, Captivated Pin
B	Gas Barrier
P	Gas Pass

Connector Data

Coupling Torque for All Type N and 7-16 DIN Connectors

Type N lbf-in (N•m)	7-16 DIN lbf-in (N•m)
15-20 (1.7-2.3)	220-265 (25-30)

Pin Depth for Type N and 7-16 DIN Connectors

Connector	Pin Depth, in (mm)*
N Male	0.210-0.230 (5.28-5.84)
N Female	0.187-0.207 (4.75-5.26)
7-16 DIN Male	0.058-0.070 (1.47-1.78)
7-16 DIN Female	0.070-0.082 (1.78-2.08)

* High frequency performance may be enhanced by adjusting pin depth to minimize the gap between male and female connectors.

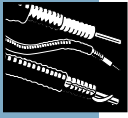

HELIAX® Connectors

The pictures below and on pages 467-470 show the various connector interfaces and body styles available for HELIAX® cables. In many cases, a single picture is used to represent several similar connectors. See the connector ordering information charts for details.

N Males



Right Angle N Males



Bulkhead N Females

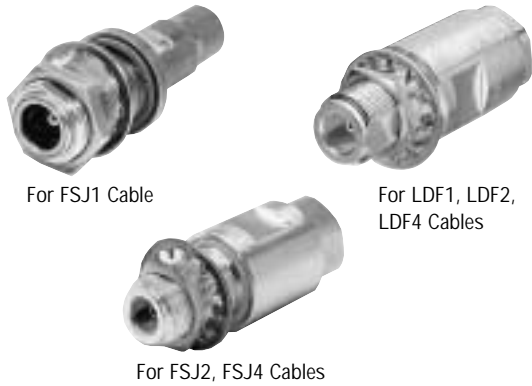

N Females



Mini UHF Male



UHF Males



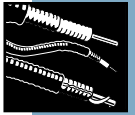

UHF Females



For FSJ1 Cable



For LDF2, EFX2, LDF4, HLT4, FSJ4 Cables



For LDF5 Cable



For HJ4, HT4, HJ5 Cables

SMA Males



For FSJ1 Cable



For FSJ1 Cable

SMA Females

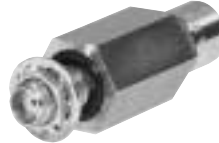

For FSJ1 Cable

4.1-9.5 DIN Males



For LDF2, FSJ4 Cables

Right Angle 7-16 DIN Males



For LDF2, EFX2 Cables



For FSJ2, FSJ4 Cables



For LDF4, LDF5 Cables

7-16 DIN Males



For FSJ1, FSJ4, FSJ2, LDF2 Cables



For LDF4, HLT4 Cables



For LDF5, LDF6, and LDF7 Cables



For LDF5, LDF6, and LDF7 Cables



For LDF7, LDF12 Cables

7-16 DIN Females



For FSJ1, FSJ2, FSJ4, LDF2, EFX2 Cables



Bulkhead for FSJ4 Cable



For LDF5 Cable



Panel Mount for FSJ1, FSJ4 Cables



For LDF4, HLT4 Cables



For LDF6, LDF7, LDF12 Cables

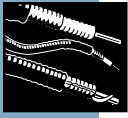

HELIAX[®] Connectors

SC Male



For LDF4, FSJ4 Cables

LC Males



For LDF4, HLT4, LDF5, Cables



For LDF6, LDF7 Cables

BNC Male



For FSJ1 Cable



For HJ5 Cable

TNC Males



For FSJ1 Cable



For LDF2, EFX2 Cables

LC Females



For LDF5, LDF7 Cables



For HJ7, LDF6 Cables

TNC Females



For FSJ1 Cable



For LDF2, EFX2, LDF4 Cables

HN Males



For FSJ4 Cable



For LDF4, HLT4, LDF5, Cables

CATV Type "F" Males



For FSJ1 Cable



For FSJ4 Cable

CATV Equipment Housing



For LDF4 Cable

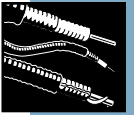

7/8" EIA Flanges



For FSJ4, LDF4, LDF5 Cables

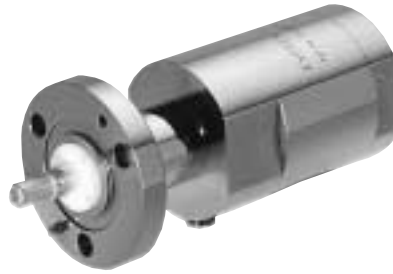

For LDF6, LDF7 Cables



For HJ4, HJ5 Cables



For HJ7, HJ12 Cables

1-5/8" EIA Flanges



For LDF6, LDF7 Cables



For HJ7, HJ12 Cables

3-1/8" EIA Flanges



Female

For HJ12, HJ8, HJ11, LDF12 Cables

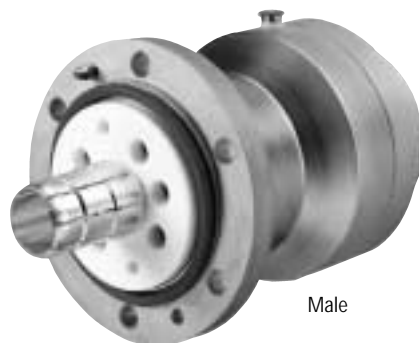

Male

For HJ8, HJ11 Cables

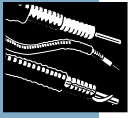

HELIAX® Connectors

4-1/2" IEC Flanges -----



For HJ11, H9 Cables



For HJ11, H9 Cables

"F" Flanges, Male -----



For LDF4, LDF5 Cables

6-1/8" EIA Flanges -----



For HJ11 Cable



For HJ9, HJ9HP Cables



For LDF6, LDF7 Cables

Splices -----



For LDF4, LDF5 Cables



For HJ4, HJ5, HJ7 Cables



For LDF6, LDF7, LDF12 Cables



For HJ8, HJ9, HJ11, HJ12 Cables

End Terminals -----



For LDF5 Cable



For HJ4, HT4, HJ5, HT5 Cables



For LDF4 Cable



For HJ7 Cable

HELIAX® Accessories



Andrew offers the industry's widest range of accessories, which are designed to be compatible with HELIAX cable. Together, HELIAX cables and accessories form a lasting and effective transmission line system. System designers and installation crews can rely on Andrew for high quality, easy to install components and reliable maintenance-free performance.

Some of Our Key Accessories Are:

Arrestor Plus Surge Protectors. Lightning surge protectors incorporate quarterwave stub technology. Designed to deliver optimum system performance and reliable equipment protection you can count on, strike after strike. Arrestor Plus is available in the slim profile universal (APM series) or the Integrated versions (APTL series) that attach directly onto LDF series HELIAX cable. Arrestor Plus gas tube arrestors (APG series) give you broadband performance and feature dc pass capability through the center conductor to the active tower top electronics. The unit's removable cap makes periodic maintenance fast and easy.

All versions incorporate silver plated components and high-pressure components throughout to ensure low levels of intermodulation and excellent VSWR performance. Arrestor Plus surge protectors are also fully weatherproof, making them suitable for a variety of outdoor applications.

Grounding Kits. All Andrew grounding kits are designed to withstand 99% of all possible lightning strikes for certainty of continued operation. The non-braided, solid copper construction of our grounding kits eliminates corrosion caused by moisture retention and "wicking". The new SureGround™ kits offer even greater installation ease than standard grounding kits. The new grounding kits are factory assembled into one component and feature a pre-formed, clip-on ground strap for easy snap-on installation. A standard weatherproofing kit (tape) is provided with SureGround versions and a weatherproofing boot is supplied with the SureGround™ Plus versions.



Entry Port Systems. Andrew offers entry port systems to meet your every need. The ArrestorPort™ II integrates your cable entry and grounding systems into a single integrated system and cuts installation time and component costs. It is designed to work with the Arrestor Plus® Surge Protectors. The new, low cost, SNAP-IN Entry port quickly and easily snaps into a hole in a cabinet or metal plate. It's used in combination with our one-piece entry boot to adapt to your requirements. For traditional installations consider our standard entry port products.

Hangers. Stainless steel construction of both the standard and our new Snap-in hangers ensures corrosion resistance and long life. The new Snap-In hangers feature an ergonomic design that provides easy attachment with no hardware required. Our Click-On hanger products are stackable and install in minutes to provide a perfect fit for applications where space is tight. Click-On hangers are manufactured from tough, UV-resistant material and set the standard for durability, simplicity, and cost effectiveness.

Weatherproofing. The WeatherShield™ Connection Protection Housing provides you with security against water. WeatherShield easily installs in seconds, to

complete your transmission line system and protect against the environment. WeatherShield provides an additional measure of system protection by providing a water-tight seal around the cable and dampening the vibration that can loosen connector interfaces. The WeatherShield takes just seconds to install. Simply place the WeatherShield around your connection and snap in place. No tapes, heat guns or shrink tubes are required.

EASIX® Plus Cable Preparation Tools. Our EASIX Plus Cable Prep tools provide you with all you need to install HELIAX connectors on HELIAX Cable. EASIX Plus automated tools dramatically reduce cable preparation time and expense while improving overall system performance. Fit the EASIX Plus tool to any standard drill and the tool does the rest. You will be able to fit your connector in about 15 seconds and your connector attachments will be consistent, reliable, and repeatable. For greatest accuracy, when installing connectors, we recommend that you use our pre-set torque wrenches. This will ensure the high quality protection and performance that you expect from Andrew.

Andrew Factory Made Cable Assemblies



Andrew has cable assembly facilities all over the world to provide you with the best jumper quality and service. Our local assembly locations can provide you with fast delivery, often in 24 hours.

Making assemblies in the field can be difficult and expensive. Proper training, tools and environmental conditions can all impact the cost and quality of a cable assembly. As you know, a poorly made cable assembly can affect system performance.

When you specify or purchase a jumper from Andrew, you can rest assured that the product has been manufactured by highly trained individuals utilizing factory automated processes. We are so confident in our quality that we guarantee it!

Check out all the advantages of the Andrew factory made cable assembly program:

- *Fast delivery...When and where you want it*
- *Popular jumpers are in stock for immediate delivery...No waiting*
- *100% testing...Ensures performance*
- *10 year warranty...Cable, connectors, and attachment are guaranteed*
- *Attachment performed by highly trained personnel... We do the job right*
- *Special lengths per your specifications*
- *Select from the wide variety of Andrew cables and connectors... One-stop-shopping simplifies sourcing*
- *Jumpers are available for flame retardant, high power/high temperature, and plenum applications*

HELIAX® coaxial cables are available with connectors attached at one or both ends or with both connectors unattached.

Ordering Information

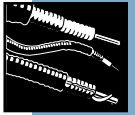

To order, please specify the following:

- Specify cable or waveguide Type Number and length in feet or meters.
- For low-VSWR cables and for elliptical waveguides, specify the operating frequency band when requested. VSWR specifications for various frequency bands are presented on the product information pages.
Frequency band codes, which are included in the identifying Andrew Type Number, are used with most standard bands of low VSWR cable and premium elliptical waveguide. For example, the -59 suffix for EWP52-59 designates a frequency band of 5.925 - 6.425 GHz. Please use these codes, where applicable.
- Specify connector Type Numbers and "attached" or "unattached". When attached connectors on an assembly are different, specify which is "first off" the reel.
- Specify any special requirements:
 - Special marking on packages
 - Packaging requirements (standard, export or special)
 - Special inspection requirements, such as customer, government, certificate of compliance
- Specify mode of shipment (surface, air or ocean) and requested ship date.

Sample orders are illustrated below.

Sample Orders

	Andrew Type Number	Description	Frequency (where applicable)	Quantity	Length Each	Total Length	Unit or Per Foot Price	Extended Price
Cable, Factory Assembly	LDF5P-50A-18	HELIAX Coaxial Cable Assembly 1850 -1990 MHz		1	290 ft	290 ft		
	L5PDM	Connector, attached, first off		1				
	L5PNM	Connector, attached, last off		1				
Bulk Cable and Connectors	LDF5-50A	HELIAX Coaxial Cable		2	700 ft	1400 ft		
	L5PNM	Connector, unattached		8				
Cable with One Attached Connector	LDF5-50A	HELIAX Coaxial Cable		1	310 ft	310 ft		
	L5PNM	Connector, attached, first off		1				
	L5PNM	Connector, unattached		1				
Elliptical Waveguide Factory Assembly	EWP52-59	Elliptical Waveguide 5.925 - 6.425 GHz		1	290 ft	290 ft		
	252DET	Connector, attached, first off		1				
	152DET	Connector, attached, last off		1				
Bulk Elliptical Waveguide and Connectors	EWP52-59	Elliptical Waveguide 5.925 - 6.425 GHz		2	700 ft	1400 ft		
	252DET	Connector, unattached		8				
Elliptical Waveguide with One Attached Connector	EWP52-59	Elliptical Waveguide 5.925 - 6.425 GHz		1	310 ft	310 ft		
	252DET	Connector, attached, first off		1				
	152DET	Connector, unattached		1				

*For cables and waveguides, specify whether connectors should be factory attached or shipped loose. When attached connectors on an assembly are different, specify which is first off the reel. For microwave antennas, specify any desired options.

Special marking on packages: _____

Packing requirements: Standard Export
 Special (specify) _____

Ship by: Surface Air Ocean
 Requested Carrier _____
 (If none specified, we will use the most economical method)

Requested ship date: _____
 OK to ship early?
 Yes No Partial OK? Yes No

Shipping charges: Collect Prepay and bill Quoted fixed freight amount
 Sales: Applicable Not Applicable
 Resale no. _____

Specify special inspection requirements, such as customer, government, certificate of compliance.





1/4" Superflexible Foam Dielectric, FSJ Series – 50-ohm

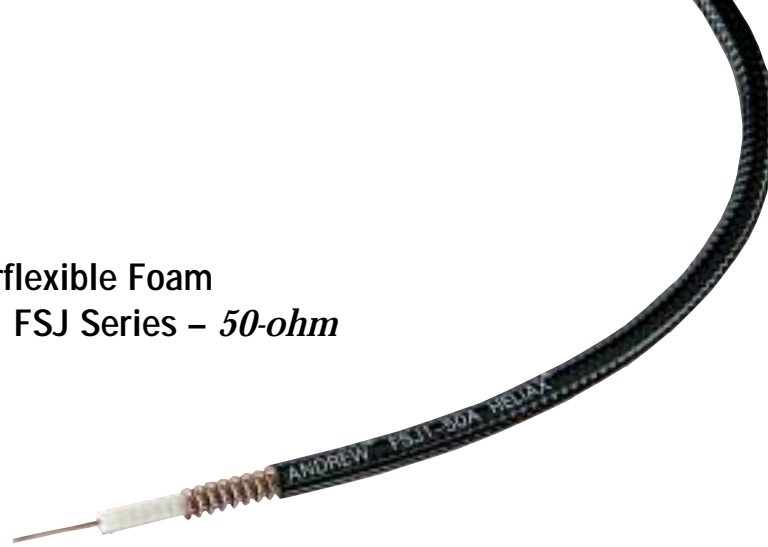

FSJ1-50A

Description	Type No.
Cable Ordering Information	
Standard Superflexible Cable	
1/4" Standard Cable, Standard Jacket	FSJ1-50A
Fire Retardant Cables	
1/4" Fire Retardant Jacket (CATVX)	FSJ1RN-50B
1/4" Fire Retardant Jacket (CATVR)	FSJ1RN-50B
Low VSWR and Specialized Cables	
1/4" Low VSWR, specify operating band	FSJ1P-50A-(**)
Phase Stabilized and Phase Measured Cable	See page 590
Jumper Cable Assemblies – See page 584	

** Insert suffix number from "Low VSWR Specifications" table, page 476.

Characteristics

Electrical	
Impedance, ohms	50 ± 1
Maximum Frequency, GHz	20.4
Velocity, percent	84
Peak Power Rating, kW	6.4
dc Resistance, ohms/1000 ft (1000 m)	
Inner	3.0 (9.8)
Outer	2.0 (6.5)
dc Breakdown, volts	1600
Jacket Spark, volts RMS	5000
Capacitance, pF/ft (m)	24.2 (79.4)
Inductance, µH/ft (m)	0.061 (0.200)
Mechanical	
Outer Conductor	Copper
Inner Conductor	Cu-Clad Al
Diameter over Jacket, standard jacket, in (mm)	0.29 (7.4)
Diameter over Jacket, fire-retardant jacket, in (mm)	0.29 (7.4)
Diameter Copper Outer Conductor, in (mm)	0.25 (6.4)
Diameter Inner Conductor, in (mm)	0.075 (1.9)
Minimum Bending Radius, in (mm)	1 (25)
Number of Bends, minimum (typical)	15 (20)
Bending Moment, lb-ft (N·m)	0.8 (1.1)
Cable Weight, lb/ft (kg/m)	0.045 (0.067)
Tensile Strength, lb (kg)	150 (68)
Flat Plate Crush Strength, lb/in (kg/mm)	100 (1.8)

Attenuation and Average Power

Frequency MHz	Attenuation dB/100 ft	Attenuation dB/100 m	Average Power, kW
0.5	0.124	0.407	6.40
1	0.176	0.577	6.40
1.5	0.215	0.707	6.40
2	0.249	0.816	6.40
10	0.559	1.83	3.97
20	0.792	2.60	2.80
30	0.973	3.19	2.28
50	1.26	4.14	1.76
88	1.68	5.52	1.32
100	1.79	5.89	1.23
108	1.87	6.13	1.19
150	2.21	7.25	1.00
174	2.39	7.82	0.929
200	2.56	8.41	0.865
300	3.16	10.4	0.701
400	3.67	12.1	0.603
450	3.91	12.8	0.567
500	4.13	13.5	0.537
512	4.18	13.7	0.530
600	4.54	14.9	0.488
700	4.93	16.2	0.450
800	5.29	17.4	0.419
824	5.38	17.6	0.412
894	5.61	18.4	0.395
960	5.83	19.1	0.380
1000	5.96	19.6	0.372
1250	6.72	22.0	0.330
1500	7.41	24.3	0.299
1700	7.94	26.0	0.279
1800	8.19	26.9	0.271
2000	8.67	28.5	0.256
2100	8.91	29.2	0.249
2200	9.14	30.0	0.243
2300	9.37	30.7	0.237
3000	10.9	35.6	0.204
3400	11.6	38.2	0.191
4000	12.8	41.8	0.174
5000	14.5	47.5	0.153
6000	16.1	52.7	0.138
8000	19.0	62.4	0.117
10000	21.7	71.2	0.102
12000	24.2	79.4	0.092
14000	26.6	87.2	0.084
16000	28.8	94.6	0.077
18000	31.0	101.7	0.072
19000	32.1	105.2	0.069
20000	33.1	108.6	0.067
20400	33.5	110.0	0.066

Standard Conditions:

For Attenuation. VSWR 1.0, ambient temperature 20°C (68°F).

For Average Power. VSWR 1.0, ambient temperature 40°C (104°F), inner conductor temperature 100°C (212°F); no solar loading.

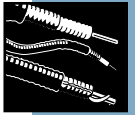

N Male
F1PNMV2-H



N Male
Right Angle
F1PNR-HC



N Female
Bulkhead
F1PNF-BH



SMA Male
F1PSM



SMA Male
Right Angle
F1PSR



SMA Female
Bulkhead
F1PSF



BNC Male
F1PBM



TNC Male
F1PTM-HF



UHF Male
41SP

Connectors

Interface	Description	Type Number	Inner Contact Attachment	Outer Contact Attachment	Plating Code	Max. Length in (mm)	Max. Dia. in (mm)
N Male	Hex Head	F1PNMV2-H	Solder	Self-Clamping	SG	2.1 (53)	0.95 (24.1)
N Male	High Freq.	F1PNM-HF	Solder	Tab Flare	SG	1.3 (33)	0.81 (20.5)
N Male	Right Angle Hex Head	F1PNR-HC	Captivated	Self-Clamping	SG	1.7/1.3 (43/33)	0.95 (24.1)
N Female	Bulkhead	F1PNF	Solder	Self-Flare	SG	2.2 (55.2)	0.58 (14.8)
N Female		F1PNF-BH	Solder	Self-Clamping	SG	2.3 (58)	0.94 (23.9)
BNC Male		F1PBM	Solder	Self-Clamping	SS	2.0 (50)	0.69 (17.5)
UHF Male		41SP	Solder	Solder	BB	1.8 (46)	0.77 (19.6)
UHF Female		41U	Solder	Solder	BS	2.1 (53)	0.77 (19.6)
SMA Male	Up to 6 GHz	F1PSM	Solder	Self-Clamping	PG	1.7 (43)	0.49 (12.5)
SMA Male	Right Angle	F1PSR	Solder	Self-Clamping	PG	1.6/0.75 (41/19)	0.50 (12.7)
SMA Female	Up to 6 GHz, Bulkhead	F1PSF	Solder	Self-Clamping	PG	1.7 (43)	0.49 (12.5)
SMA Male	Up to 18 GHz	41EWS	Solder	Tab Flare	G	0.94 (23.9)	0.40 (10.2)
SMA Female	Up to 18 GHz	41ENS	Solder	Tab Flare	G	1.00 (25.4)	0.40 (10.2)
TNC Male	11 GHz and Below	F1PTM	Solder	Self-Clamping	SG	1.68 (43)	0.57 (14.5)
TNC Female	Bulkhead	41AENT	Captivated	Tab Flare	NG	1.5 (38)	0.70 (17.8)
TNC Male	Hi Freq, Above 11 GHz	F1PTM-HF	Captivated	Tab Flare	NG	1.9 (48.8)	0.70 (17.8)
Mini-UHF Male		F1MU	Captivated	Crimp	NS	1.53 (39)	0.47 (11.9)
7-16 DIN Male		F1PDM	Solder	Self-Clamping	SS	1.82 (46.3)	1.25 (31.75)
7-16 DIN Female		F1PDF	Solder	Self-Clamping	SS	1.85 (47)	0.551 (14)
7-16 DIN Female	Panel Mount	F1PDF-PM	Solder	Self-Clamping	SS	1.85 (47)	1.26 (32)
7-16 DIN Female	Bulkhead	F1PDF-BH	Solder	Self Clamping	SS	1.85 (47)	1.62 (41)

* Stainless steel body

Plating Codes: BB - Brass Body and Pin, BS - Brass Body and Silver Plated Pin, NG - Nickel Plated Body and Gold Plated Pin, NS - Nickel Plated Body and Silver Plated Pin, PG - Passivated Body and Gold Plated Pin+A135, SG - Silver Plated Body and Gold Plated Pin, SS - Silver Plated Body and Pin, G - Stainless Steel Body and Gold Plated Pin.

Connector Accessories – See page 624

Factory Attached Connectors – For factory made cable assemblies and jumper cables, see pages 584-587.



Low VSWR Specifications, Type FSJ1P-50A-()

Frequency Band, GHz	Type No.	Using Connector Type No.**	Assembly VSWR, Maximum (R.L., dB)		
			to 10 ft (3 m)	10-20 ft (3-6 m)	20-200 ft (6-60 m)
0.01- 2.3	FSJ1P-50A-1A	N Male	1.07 (29.4)	1.13 (24.3)	1.27 (18.5)
		N Male†	1.12 (24.9)	1.15 (23.1)	1.35 (16.5)
		N Female	1.15 (23.1)	1.20 (20.8)	1.40 (15.6)
		Right Angle N Male	1.31 (17.4)	1.35 (16.5)	1.40 (15.6)
		SMA Male	1.12 (24.9)	1.25 (19.1)	1.35 (16.5)
		Right Angle SMA Male	1.30 (17.7)	1.30 (17.7)	1.40 (15.6)
		SMA Female	1.12 (24.9)	1.25 (19.1)	1.35 (16.5)
		TNC Male	1.15 (23.1)	1.20 (20.8)	1.40 (15.6)
		7-16 DIN Male	1.12 (24.9)	1.18 (21.6)	1.40 (15.6)
		7-16 DIN Female	1.17 (22.1)	1.22 (20.1)	1.40 (15.6)
0.01- 4.2	FSJ1P-50A-2A	N Male	1.15 (23.1)	1.18 (21.6)	1.31 (17.4)
		N Female†	1.40 (15.6)	1.45 (14.7)	1.50 (14.0)
		Right Angle N Male	1.38 (16.0)	1.40 (15.6)	1.50 (14.0)
		SMA Male	1.17 (22.1)	1.40 (15.6)	1.45 (14.7)
		Right Angle SMA Male	1.40 (15.6)	1.45 (14.7)	1.50 (14.0)
		SMA Female	1.17 (22.1)	1.40 (15.6)	1.45 (14.7)
		TNC Male	1.30 (17.7)	1.35 (16.5)	1.45 (14.7)
		7-16 DIN Male	1.25 (19.1)	1.30 (17.7)	1.45 (14.7)
7-16 DIN Female	1.25 (19.1)	1.30 (17.7)	1.45 (14.7)		
0.01-10.2	FSJ1P-50A-3A	N Male	1.40 (15.6)	1.45 (14.7)	1.50 (14.0)
		SMA Male	1.35 (16.5)	1.40 (15.6)	1.45 (14.7)
		SMA Female	1.40 (15.6)	1.45 (14.7)	1.50 (14.0)
		TNC Male	1.45 (14.7)	1.50 (14.0)	1.63 (12.4)
0.01-18.0	FSJ1P-50A-4A	N Male	1.55 (13.3)	1.55 (13.3)	1.63 (12.4)
		SMA Male	1.50 (14.0)	1.55 (13.3)	1.55 (13.3)
		SMA Female	1.50 (14.0)	1.55 (13.3)	1.55 (13.3)
0.806-0.960	FSJ1P-50A-40	N	1.08 (28.3)	1.10 (26.4)	1.10 (26.4)
		7-16 DIN	1.08 (28.3)	1.10 (26.4)	1.10 (26.4)
0.806-0.960 and 1.7- 2.3	FSJ1P-50A-42	N	1.10 (26.4)	1.10 (26.4)	1.10 (26.4)
		7-16 DIN	1.10 (26.4)	1.10 (26.4)	1.10 (26.4)
1.7- 2.3	FSJ1P-50A-41	N	1.10 (26.4)	1.10 (26.4)	1.10 (26.4)
		7-16 DIN	1.10 (26.4)	1.10 (26.4)	1.10 (26.4)

* Specify frequency band. ** Connectors ordered separately. VSWR values apply to straight connectors only (except where noted otherwise), are guaranteed for factory fit assemblies, and are typical for field cut lengths. If two different connector interfaces are selected, the higher VSWR value is guaranteed. † High frequency version.

Accessories

Description	Type No.
Hangers – For more hangers, adapters and mounting hardware see pages 599-607	
Insulated Hanger , single. Recommended maximum spacing is 2.5 ft (0.76 m). For different spacing recommendations, refer to Cable Hanger Spacing, page 593-598	11662-3
Angle Adapter , for insulated hanger	40430-1
Nylon Cable Tie Kit of 50, Indoor use, Recommended maximum spacing is 1.5 ft (0.5 m)	40417
Nylon Cable Tie Kit in plastic box. 100 each 4, 5.5 and 7.5 inch ties. Indoor use, Recommended maximum spacing is 1.5 ft (0.5 m)	CT-K350
Velcro Cable Ties , Black, 8 inch. Indoor Use	
Kit of 10	VCT8-10
Kit of 50	VCT8-50
Kit of 100	VCT8-100
Support/Hoisting Grip . Use at 200-ft (60m) intervals.	
Grip with one clamp	F1SGRIP
Support clamp kit of 10	F1SGRIP-1IK

Grounding and Surge Protection – for additional grounding kits and our surge protection offerings, see pages 609-616

Standard Grounding Kit	
Factory attached one-hole lug, 24" lead	223158
Factory attached two-hole lug, 24" lead	223158-2
Field attached one-hole lug, 36" lead	223158-3

Description	Type No.
Weatherproofing – for additional weatherproofing information see pages 617-618	
Cold Shrink™ Weatherproofing Kit	
5/8" Coax to 1/4" Coax	241475-13
7/8" Coax to 1/4" Coax	241475-12
1-1/4" or 1-5/8" Coax to 1/4" Coax	241475-11
1/4" to 1-1/2" Omni/Panel base Type N or DIN	241548-10
1/4" to 2" Omni/Panel base Type N or DIN	241548-11
Connector/Splice Weatherproofing Kit	221213
Entry Systems – For entry systems offerings see pages 619-620	
Standard Cable Entry Boots	
4" Boots – Three Hole:	204679A-17
Tools – for additional tool offerings see pages 620-623	
EASIX® Cutting Tool FSJ1/FSJ4	207865
DIN Connector Coupling Torque Wrench	244377
N Connector Coupling Torque Wrench	244379

Cold Shrink is a trademark of Minnesota Mining and Manufacturing Co.

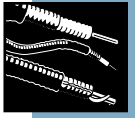

1/4" Superflexible High Power, High Temperature, Plenum, Fluoropolymer Foam Dielectric, ETS Series – 50-ohm

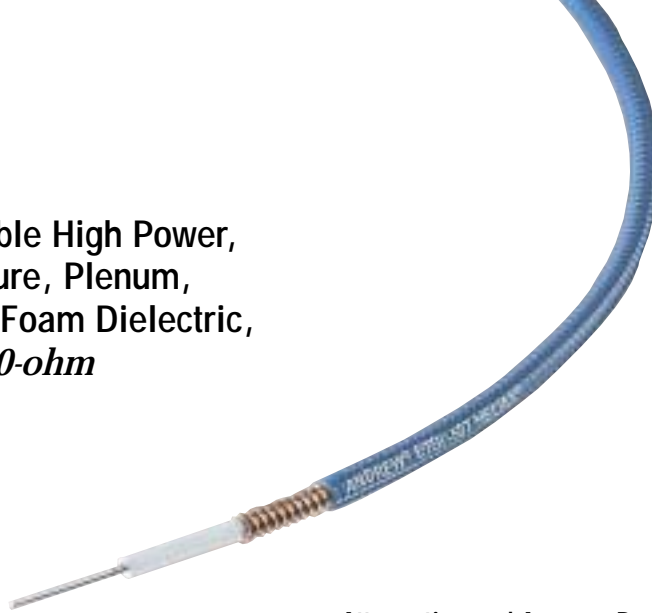

ETS1-50T

Description	Type No.
-------------	----------

Cable Ordering Information

High Power, Plenum Cables	
1/4" Fire Retardant Jacket (CATVP, UL910)	ETS1-50T
1/4" Unjacketed, Fire Retardant (CATVP, UL910)	ETS1-50
Jumper Cable Assemblies – See page 584	

Characteristics

Electrical	
Impedance, ohms	50 ± 2
Maximum Frequency, GHz	20.0
Velocity, percent	82
Peak Power Rating, kW	6.4
dc Resistance, ohms/1000 ft (1000 m)	
Inner	1.9 (6.2)
Outer	2.0 (6.5)
dc Breakdown, volts	1600
Jacket Spark, volts RMS	4000
Capacitance, pF/ft (pF/m)	24.6 (80.6)
Inductance, µH/ft (µH/m)	0.063 (0.205)
Mechanical	
Outer Conductor	Copper
Inner Conductor	Silver plated copper
Diameter over Jacket, in (mm)	0.29 (7.4)
Diameter over Copper Outer Conductor, in (mm)	0.25 (6.4)
Minimum Bending Radius, in (mm)	1 (25)
Number of Bends, minimum (typical)	15 (20)
Bending Moment, lb-ft (N·m)	0.6 (0.8)
Cable Weight, lb/ft (kg/m)	0.066 (0.098)
Tensile Strength, lb (kg)	150 (68)
Flat Plate Crush Strength, lb/in (kg/mm)	100 (1.8)

Attenuation and Average Power Ratings

Frequency MHz	Attenuation dB/100 ft	Attenuation dB/100 m	ETS1-50T ¹	ETS1-50 ²
			Avg. Power kW	Avg. Power kW
0.5	0.124	0.408	6.40	6.40
1	0.176	0.577	6.40	6.40
1.5	0.216	0.707	6.40	6.40
2	0.249	0.817	6.40	6.40
10	0.56	1.83	6.40	6.40
20	0.79	2.60	6.40	6.40
30	0.97	3.19	5.48	6.13
50	1.26	4.12	4.23	4.73
88	1.67	5.49	3.18	3.55
100	1.79	5.86	2.98	3.33
108	1.86	6.09	2.86	3.20
150	2.20	7.21	2.42	2.71
174	2.37	7.77	2.25	2.51
200	2.54	8.35	2.09	2.34
300	3.13	10.3	1.70	1.90
400	3.63	11.9	1.46	1.64
450	3.86	12.7	1.38	1.54
500	4.08	13.4	1.30	1.46
512	4.13	13.5	1.29	1.44
600	4.48	14.7	1.19	1.33
700	4.86	15.9	1.10	1.22
800	5.21	17.1	1.02	1.14
824	5.29	17.4	1.01	1.12
894	5.52	18.1	0.964	1.08
960	5.73	18.8	0.928	1.04
1000	5.86	19.2	0.909	1.02
1250	6.59	21.6	0.808	0.904
1500	7.25	23.8	0.733	0.82
1700	7.75	25.4	0.686	0.768
1800	7.99	26.2	0.666	0.745
2000	8.46	27.7	0.629	0.704
2100	8.68	28.5	0.613	0.686
2200	8.90	29.2	0.598	0.669
2300	9.12	29.9	0.584	0.653
3000	10.5	34.5	0.506	0.566
3400	11.3	37.0	0.472	0.529
4000	12.3	40.4	0.432	0.484
5000	13.9	45.7	0.382	0.428
6000	15.4	50.6	0.345	0.386
8000	18.1	59.5	0.294	0.329
10000	20.6	67.5	0.259	0.289
12000	22.9	75.0	0.233	0.261
14000	25.0	82.0	0.213	0.238
16000	27.0	88.7	0.197	0.220
18000	29.0	95.1	0.184	0.206
19000	29.9	98.2	0.178	0.199
20000	30.9	101.3	0.173	0.193

Standard Conditions: For Attenuation: VSWR 1.0, ambient temperature 20°C (68°F).

1. For Average Power, Type ETS1-50T (jacketed): VSWR 1.0 ambient temperature 40°C (104°F), inner conductor temperature 200°C (392°F).
2. For Average Power, Type ETS1-50 (unjacketed): VSWR 1.0 ambient temperature 40°C (104°F), inner conductor temperature 250°C (482°F); no solar loading.

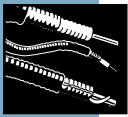

N Male
F1PNMV2-H



N Male
Right Angle
F1PNR-HC



N Female
Bulkhead
F1PNF-BH



SMA Male
F1PSM



SMA Male
Right Angle
F1PSR



SMA Female
Bulkhead
F1PSF



BNC Male
F1PBM



TNC Male
F1PTM-HF



UHF Male
41SP

Connectors

Interface	Description	Type Number	Inner Contact Attachment	Outer Contact Attachment	Plating Code	Max. Length in (mm)	Max. Dia. in (mm)
N Male	Hex Head	F1PNMV2-H	Solder	Self-Clamping	SG	2.1 (53)	0.95 (24.1)
N Male	High Freq.	F1PNM-HF	Solder	Tab Flare	SG	1.3 (33)	0.81 (20.5)
N Male	Hex Head Right Angle	F1PNR-HC	Captivated	Self-Clamping	SG	1.7/1.3 (43/33)	0.95 (24.1)
N Female		F1PNF	Solder	Self-Flare	SG	2.2 (55.2)	0.58 (14.8)
N Female	Bulkhead	F1PNF-BH	Solder	Self-Clamping	SG	2.3 (58)	0.94 (23.9)
BNC Male		F1PBM	Solder	Self-Clamping	SS	2.0 (50)	0.69 (17.5)
UHF Male		41SP	Solder	Solder	BB	1.8 (46)	0.77 (19.6)
UHF Female		41U	Solder	Solder	BS	2.1 (53)	0.77 (19.6)
SMA Male	Up to 6 GHz	F1PSM	Solder	Self-Clamping	PG	1.7 (43)	0.49 (12.5)
SMA Male	Right Angle	F1PSR	Solder	Self-Clamping	PG	1.6/0.75 (41/19)	0.50 (12.7)
SMA Female	Up to 6 GHz, Bulkhead	F1PSF	Solder	Self-Clamping	PG	1.7 (43)	0.49 (12.5)
SMA Male	Up to 18 GHz	41EWS	Solder	Tab Flare	G	0.94 (23.9)	0.40 (10.2)
SMA Female	Up to 18 GHz	41ENS	Solder	Tab Flare	G	1.00 (25.4)	0.40 (10.2)
TNC Male	11 GHz and Below	F1PTM	Solder	Self-Clamping	SG	1.68 (43)	0.57 (14.5)
TNC Female	Bulkhead	41AENT	Captivated	Tab Flare	NG	1.5 (38)	0.70 (17.8)
TNC Male	Hi Freq, Above 11 GHz	F1PTM-HF	Captivated	Tab Flare	NG	1.9 (48.8)	0.70 (17.8)
Mini-UHF Male		F1MU	Captivated	Crimp	NS	1.53 (39)	0.47 (11.9)
7-16 DIN Male		F1PDM	Solder	Self-Clamping	SS	1.82 (46.3)	1.25 (31.75)
7-16 DIN Female		F1PDF	Solder	Self-Clamping	SS	1.85 (47)	0.551 (14)
7-16 DIN Female	Panel Mount	F1PDF-PM	Solder	Self-Clamping	SS	1.85 (47)	1.26 (32)
7-16 DIN Female	Bulkhead	F1PDF-BH	Solder	Self Clamping	SS	1.85 (47)	1.62 (41)

* Stainless steel body

Plating Codes: BB - Brass Body and Pin, BS - Brass Body and Silver Plated Pin, NG - Nickel Plated Body and Gold Plated Pin, NS- Nickel Plated Body and Silver Plated Pin, PG - Passivated Body and Gold Plated Pin+A135, SG - Silver Plated Body and Gold Plated Pin, SS - Silver Plated Body and Pin, G - Stainless Steel Body and Gold Plated Pin.

Connector Accessories – See page 624.

Factory Attached Connectors – For factory made cable assemblies and jumper cables, see pages 584-587.

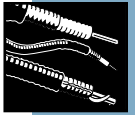

Accessories

Description	Type No.
Hangers – For more hangers, adapters and mounting hardware see pages 599-607	
Insulated Hanger , single. Recommended maximum spacing is 2.5 ft (0.76 m). For different spacing recommendations, refer to Cable Hanger Spacing, page 593-598	11662-3
Angle Adapter , for insulated hanger	40430-1
Nylon Cable Tie Kit of 50, Indoor use, Recommended maximum spacing is 1.5 ft (0.5 m)	40417
Nylon Cable Tie Kit in plastic box. 100 each 4, 5.5 and 7.5 inch ties. Indoor use, Recommended maximum spacing is 1.5 ft (0.5 m)	CT-K350
Velcro Cable Ties , Black, 8 inch. Indoor Use	
Kit of 10	VCT8-10
Kit of 50	VCT8-50
Kit of 100	VCT8-100
Grounding and Surge Protection – for additional grounding kits and our surge protection offerings, see pages 609-616	
Standard Grounding Kit	
Factory attached one-hole lug, 24" lead	223158
Factory attached two-hole lug, 24" lead	223158-2
Field attached one-hole lug, 36" lead	223158-3

Description	Type No.
Weatherproofing – for additional weatherproofing information see pages 617-618	
Cold Shrink Weatherproofing Kit	
5/8" Coax to 1/4" Coax	241475-13
7/8" Coax to 1/4" Coax	241475-12
1-1/4" or 1-5/8" Coax to 1/4" Coax	241475-11
1/4" to 1-1/2" Omni/Panel base Type N or DIN	241548-10
1/4" to 2" Omni/Panel base Type N or DIN	241548-11
Connector/Splice Weatherproofing Kit	221213
Entry Systems – For entry systems offerings see pages 619-620	
Standard Cable Entry Boots	
4" Boots – Three Hole:	204679A-17
Tools – for additional tool offerings see pages 620-623	
EASIA [®] Cutting Tool FSJ1/FSJ4	207865
DIN Connector Coupling Torque Wrench	244377
N Connector Coupling Torque Wrench	244379



3/8" Superflexible Foam Dielectric, FSJ Series – 50-ohm



FSJ2-50

Description	Type No.
Cable Ordering Information	
Standard Superflexible Cable	
3/8" Standard Cable, Standard Jacket	FSJ2-50
Fire Retardant Cables	
3/8" Fire Retardant Jacket (CATVX)	FSJ2RN-50
3/8" Fire Retardant Jacket (CATVR)	FSJ2RN-50
Low VSWR and Specialized Cables	
3/8" Low VSWR, specify operating band	FSJ2P-50-(**)
Phase Stabilized and Phase Measured Cable	See page 590
Jumper Cable Assemblies – See page 584	
** Insert suffix number from "Low VSWR Specifications" table, page 481	
Characteristics	
Electrical	
Impedance, ohms	50 ± 1
Maximum Frequency, GHz	13.4
Velocity, percent	83
Peak Power Rating, kW	13.2
dc Resistance, ohms/1000 ft (1000 m)	
Inner	1.29 (4.23)
Outer	1.52 (4.99)
dc Breakdown, volts	2300
Jacket Spark, volts RMS	5000
Capacitance, pF/ft (m)	24.3 (79.7)
Inductance, µH/ft (m)	0.061 (0.200)
Mechanical	
Outer Conductor	Copper
Inner Conductor	Copper-Clad Aluminum
Diameter over Jacket, standard jacket, in (mm)	0.415 (10.5)
Diameter over Jacket, fire-retardant jacket, in (mm)	0.425 (10.8)
Diameter over Copper Outer Conductor, in (mm)	0.375 (9.5)
Diameter Inner Conductor, in (mm)	0.110 (2.8)
Minimum Bending Radius, in (mm)	1 (25)
Number of Bends, minimum (typical)	20 (50)
Bending Moment, lb-ft (N•m)	1.7 (2.3)
Cable Weight, lb/ft. (kg/m)	0.078 (0.12)
Tensile Strength, lb (kg)	210 (95)
Flat Plate Crush Strength, lb/in (kg/mm)	100 (1.8)

Attenuation and Average Power Ratings

Frequency MHz	Attenuation dB/100 ft	Attenuation dB/100 m	Average Power, kW
0.5	0.082	0.270	13.2
1	0.117	0.383	13.2
1.5	0.143	0.469	13.2
2	0.165	0.542	13.2
10	0.372	1.22	6.92
20	0.528	1.73	4.87
30	0.649	2.13	3.97
50	0.842	2.76	3.06
88	1.13	3.69	2.29
100	1.20	3.94	2.14
108	1.25	4.10	2.06
150	1.48	4.86	1.74
174	1.60	5.25	1.61
200	1.72	5.65	1.49
300	2.13	6.99	1.21
400	2.48	8.14	1.04
450	2.64	8.66	0.975
500	2.79	9.17	0.921
512	2.83	9.28	0.910
600	3.08	10.1	0.836
700	3.35	11.0	0.769
800	3.60	11.8	0.715
824	3.66	12.0	0.704
894	3.82	12.5	0.673
960	3.97	13.0	0.648
1000	4.06	13.3	0.634
1250	4.59	15.1	0.580
1500	5.08	16.7	0.507
1700	5.45	17.9	0.472
1800	5.63	18.5	0.457
2000	5.97	19.6	0.431
2100	6.14	20.1	0.419
2200	6.30	20.7	0.409
2300	6.47	21.2	0.398
3000	7.53	24.7	0.342
3400	8.09	26.6	0.318
4000	8.90	29.2	0.289
5000	10.2	33.3	0.254
6000	11.3	37.2	0.228
8000	13.5	44.3	0.191
10000	15.5	50.8	0.166
12000	17.4	57.0	0.148
13400	18.6	61.1	0.138

Standard Conditions:

For attenuation, VSWR 1.0, ambient temperature 20°C (68°F).

For Average Power, VSWR 1.0, ambient temperature 40°C (104°F), inner conductor temperature 100°C (212°F), no solar loading.

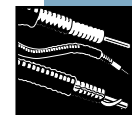

N Male
F2PNM-H



7-16 DIN Female
F2PDF



7-16 DIN Male
F2PDM-C



N Female
F2PNF



7-16 DIN Male
Right Angle
F2PDR-C

Connectors

Interface	Description	Type Number	Inner Contact Attachment	Outer Contact Attachment	Plating Code	Max. Length in (mm)	Max. Dia. in (mm)
N Male	Hex Head	F2PNM-H	Solder	Self-Flare	SG	1.9 (48)	0.94 (23)
N Male	Hex Head	F2PNM-HC	Captivated	Self-Flare	SG	1.9 (48)	0.94 (23)
N Female		F2PNF	Solder	Self-Flare	SG	2.1 (53)	0.67 (17)
N Female		F2PNF-C	Captivated	Self-Flare	SG	2.1 (53)	0.64 (16)
N Female	Bulkhead	F2PNF-BH	Solder	Self-Flare	SG	2.1 (53)	0.95 (24)
7-16 DIN Male		F2PDM	Solder	Self-Flare	SS	2.2 (57)	1.4 (36)
7-16 DIN Male		F2PDM-C	Captivated	Self-Flare	SS	2.1 (53)	1.4 (36)
7-16 DIN Female		F2PDF	Solder	Self-Flare	SS	2.2 (56)	1.1 (28)
7-16 DIN Female		F2PDF-C	Captivated	Self-Flare	SS	2.1 (51.6)	0.79 (20)
7-16 DIN Female	Panel Mount	F2PDF-PM	Solder	Self-Flare	SS	2.2 (56)	1.1 (28)
7-16 DIN Male	Right Angle	F2PDR-C	Captivated	Self-Flare	SS	1.7/1.3 (43/34)	1.4 (36)

Plating Codes: SG - Silver Plated Body and Gold Plated Pin, SS - Silver Plated Body and Pin, BS - Brass Body and Silver Plated Pin.

Low VSWR Specifications, Type FSJ2P-50-()

Frequency Band, GHz	Type No.	Using Connector Type**	Assembly VSWR, Maximum (R.L., dB)		
			to 10 ft (3 m)	10-20 ft (3-6 m)	20-200 ft (6-60 m)
0.806-0.960	FSJ2P-50-40	N	1.08 (28.3)	1.10 (26.4)	1.10 (26.4)
		7-16 DIN	1.08 (28.3)	1.10 (26.4)	1.10 (26.4)
0.806-0.960 and 1.7- 2.3	FSJ2P-50-42	N	1.10 (26.4)	1.10 (26.4)	1.10 (26.4)
		7-16 DIN	1.10 (26.4)	1.10 (26.4)	1.10 (26.4)
1.7- 2.3	FSJ2P-50-41	N	1.10 (26.4)	1.10 (26.4)	1.10 (26.4)
		7-16 DIN	1.10 (26.4)	1.10 (26.4)	1.10 (26.4)
Up to 2.3 *	FSJ2P-50-1	N Male	1.10 (26.4)	1.15 (23.1)	1.20 (20.8)
Up to 5.0 *	FSJ2P-50-2	N Male	1.20 (20.8)	1.20 (20.8)	1.25 (19.1)
Up to 8.5 *	FSJ2P-50-3	N Male	1.40 (15.6)	1.40 (15.6)	1.40 (15.6)
Up to 13.4 *	FSJ2P-50-4	N Male	1.50 (14.0)	1.50 (14.0)	1.50 (14.0)

* Specify operating band. ** Connectors ordered separately.

VSWR values apply to straight connectors only, are guaranteed for factory fit assemblies, and are typical for field cut lengths. If two different connector interfaces are selected, the higher VSWR value is guaranteed.

Connector Accessories – See page 624

Factory Attached Connectors – For factory made cable assemblies and jumper cables, see pages 584-587.



Accessories

Description	Type No.
Hangers – For more hangers, adapters and mounting hardware see pages 599-607	
Insulated Hanger , single. Recommended maximum spacing is 2.5 ft (0.76 m). For different spacing recommendations, refer to Cable Hanger Spacing, page 593-598	11662-3
Angle Adapter , for insulated hanger	40430-1
Nylon Cable Tie Kit of 50, Indoor use, Recommended maximum spacing is 1.5 ft (0.5 m)	40417
Nylon Cable Tie Kit in plastic box. 100 each 4, 5.5 and 7.5 inch ties. Indoor use, Recommended maximum spacing is 1.5 ft (0.5 m)	CT-K350
Velcro Cable Ties , Black, 8 inch. Indoor Use	
Kit of 10	VCT8-10
Kit of 50	VCT8-50
Kit of 100	VCT8-100
Support/Hoisting Grip . Use at 200-ft (60m) intervals.	
Grip with one clamp	F2SGRIP
Support clamp kit of 10	F2SGRIP-2IK
Grounding and Surge Protection – for additional grounding kits and our surge protection offerings, see pages 609-616	
Standard Grounding Kit	
Factory attached one-hole lug, 24" lead	223158
Factory attached two-hole lug, 24" lead	223158-2
Field attached one-hole lug, 36" lead	223158-3

Description	Type No.
Weatherproofing – for additional weatherproofing information see pages 617-618	
Cold Shrink Weatherproofing Kit	
3/8" Coax to 3/8" Coax with N Connector	241475-10
5/8" Coax to 3/8" Coax	241475-13
7/8" Coax to 3/8" Coax	241475-9
1-1/4" or 1-5/8" Coax to 3/8" Coax	241475-5A
2-1/4" Coax to 3/8" Coax	241475-8
3/8" Coax to 1-1/2" Omni Panel Base type N or DIN	241548-8
3/8" to 2" Omni Panel Base type N or DIN	241548-9
Connector/Splice Weatherproofing Kit	221213
Entry Systems – For entry systems offerings see pages 619-620	
Standard Cable Entry Boots	
4" Boots – Three Hole:	204679A-19
5" Boots – One Hole:	48939A-16
Tools – for additional tool offerings see pages 620-623	
EASIX® Cutting Tool FSJ2/FSJ4	241372
DIN Connector Coupling Torque Wrench	244377
N Connector Coupling Torque Wrench	244379

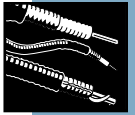

3/8" Superflexible High Power, High Temperature, Expanded PTFE Foam Dielectric, ETS Series – 50-ohm



ETS2-50T

Description	Type No.
Cable Ordering Information	
High Power, Plenum Cables	
3/8" Fire Retardant Jacket (CATVP)	ETS2-50T
3/8" Unjacketed, Fire Retardant (CATVP)	ETS2-50
Characteristics	
Electrical	
Impedance, ohms	50 ± 2
Maximum Frequency, GHz	13.4
Velocity, percent	83
Peak Power Rating, kW	13.2
dc Resistance, ohms/1000 ft (1000 m)	
Inner	1.29 (4.23)
Outer	1.52 (4.99)
dc Breakdown, volts	2300
Jacket Spark, volts RMS	4000
Capacitance, pF/ft (m)	24.3 (79.7)
Inductance, µH/ft (m)	0.061 (0.200)
Mechanical	
Outer Conductor	Copper
Inner Conductor	Silver Plated, Copper-Clad Aluminum
Diameter over Jacket, in (mm)	0.415 (10.5)
Diameter over Copper Outer Conductor, in (mm)	0.375 (9.5)
Minimum Bending Radius, in (mm)	1 (25)
Number of Bends, minimum (typical)	20 (50)
Bending Moment, lb-ft (N·m)	1.7 (2.3)
Cable Weight, lb/ft. (kg/m)	0.087 (0.13)
Tensile Strength, lb (kg)	210 (95)
Flat Plate Crush Strength, lb/in (kg/mm)	100 (1.8)

Attenuation and Average Power Ratings

Frequency MHz	Attenuation dB/100 ft	Attenuation dB/100 m	ETS2-50T ¹	ETS2-50 ²
			Avg. Power kW	Avg. Power kW
0.5	0.083	0.271	13.2	13.2
1	0.117	0.383	13.2	13.2
1.5	0.143	0.470	13.2	13.2
2	0.166	0.543	13.2	13.2
10	0.373	1.22	13.2	13.2
20	0.531	1.74	12.2	13.2
30	0.653	2.14	9.89	11.3
50	0.849	2.79	7.61	8.67
88	1.14	3.73	5.68	6.47
100	1.22	3.99	5.31	6.05
108	1.27	4.16	5.10	5.82
150	1.51	4.94	4.29	4.89
174	1.63	5.34	3.97	4.52
200	1.75	5.75	3.69	4.20
300	2.18	7.14	2.97	3.39
400	2.54	8.34	2.54	2.90
450	2.71	8.89	2.39	2.72
500	2.87	9.41	2.25	2.57
512	2.91	9.54	2.22	2.53
600	3.17	10.4	2.04	2.32
700	3.45	11.3	1.87	2.13
800	3.72	12.2	1.74	1.98
824	3.78	12.4	1.71	1.95
894	3.96	13.0	1.63	1.86
960	4.12	13.5	1.57	1.79
1000	4.22	13.8	1.53	1.75
1250	4.78	15.7	1.35	1.54
1500	5.31	17.4	1.22	1.39
1700	5.71	18.7	1.13	1.29
1800	5.90	19.4	1.10	1.25
2000	6.28	20.6	1.03	1.17
2100	6.46	21.2	1.00	1.14
2200	6.64	21.8	0.975	1.11
2300	6.81	22.4	0.950	1.08
3000	7.98	26.2	0.811	0.924
3400	8.61	28.2	0.752	0.847
4000	9.50	31.2	0.681	0.776
5000	10.9	35.8	0.593	0.676
6000	12.2	40.1	0.529	0.603
8000	14.7	48.2	0.441	0.502
10000	17.0	55.8	0.381	0.434
12000	19.2	62.9	0.338	0.385
13400	20.7	67.8	0.314	0.358

Standard Conditions: For Attenuation: VSWR 1.0, ambient temperature 20°C (68°F).

1. For Average Power, Type ETS2-50T (jacketed): VSWR 1.0 ambient temperature 40°C (104°F), inner conductor temperature 200°C (392°F).

2. For Average Power, Type ETS2-50 (unjacketed): VSWR 1.0 ambient temperature 40°C (104°F), inner conductor temperature 250°C (482°F); no solar loading.



N Male
F2PNM-H



7-16 DIN Female
F2PDF



7-16 DIN Male
F2PDM-C



N Female
F2PNF



7-16 DIN Male
Right Angle – F2PDR-C

Connectors

Interface	Description	Type Number	Inner Contact Attachment	Outer Contact Attachment	Plating Code	Max. Length in (mm)	Max. Dia. in (mm)
N Male	Hex Head	F2PNM-H	Solder	Self-Flare	SG	1.9 (48)	0.94 (23)
N Male	Hex Head	F2PNM-HC	Captivated	Self-Flare	SG	1.9 (48)	0.94 (23)
N Female		F2PNF	Solder	Self-Flare	SG	2.1 (53)	0.67 (17)
N Female		F2PNF-C	Captivated	Self-Flare	SG	2.1 (53)	0.64 (16)
N Female	Bulkhead	F2PNF-BH	Solder	Self-Flare	SG	2.1 (53)	0.95 (24)
7-16 DIN Male		F2PDM	Solder	Self-Flare	SS	2.2 (57)	1.4 (36)
7-16 DIN Male		F2PDM-C	Captivated	Self-Flare	SS	2.1 (53)	1.4 (36)
7-16 DIN Female		F2PDF	Solder	Self-Flare	SS	2.2 (56)	1.1 (28)
7-16 DIN Female		F2PDF-C	Captivated	Self-Flare	SS	2.1 (51.6)	0.79 (20)
7-16 DIN Female	Panel Mt.	F2PDF-PM	Solder	Self-Flare	SS	2.2 (56)	1.1 (28)
7-16 DIN Male	Right Angle	F2PDR-C	Captivated	Self-Flare	SS	1.7/1.3 (43/34)	1.4 (36)

Plating Codes: SG - Silver Plated Body and Gold Plated Pin, SS - Silver Plated Body and Pin, BS - Brass Body and Silver Plated Pin.

Accessories

Description	Type No.
Hangers – For more hangers, adapters and mounting hardware see pages 599-607	
Insulated Hanger , single. Recommended maximum spacing is 2.5 ft (0.76 m). For different spacing recommendations, refer to Cable Hanger Spacing, page 593-598	11662-3
Angle Adapter , for insulated hanger	40430-1
Nylon Cable Tie Kit of 50, Indoor use, Recommended maximum spacing is 1.5 ft (0.5 m)	40417
Nylon Cable Tie Kit in plastic box. 100 each 4, 5.5 and 7.5 inch ties. Indoor use, Recommended maximum spacing is 1.5 ft (0.5 m)	CT-K350
Velcro Cable Ties , Black, 8 inch. Indoor Use	
Kit of 10	VCT8-10
Kit of 50	VCT8-50
Kit of 100	VCT8-100

Grounding and Surge Protection – for additional grounding kits and our surge protection offerings, see pages 609-616

Standard Grounding Kit

Factory attached one-hole lug, 24" lead	223158
Factory attached two-hole lug, 24" lead	223158-2
Field attached one-hole lug, 36" lead	223158-3

Description	Type No.
Weatherproofing – for additional weatherproofing information see pages 617-618	
Connector/Splice Weatherproofing Kit	221213
Entry Systems – For entry systems offerings see pages 619-620	
Standard Cable Entry Boots	
4" Boots – Three Hole:	204679A-19
5" Boots – One Hole:	48939A-16
Tools – for additional tool offerings see pages 620-623	
EASIAIX® Cutting Tool FSJ2/FSJ4	241372
DIN Connector Coupling Torque Wrench	244377
N Connector Coupling Torque Wrench	244379

Connector Accessories – See page 624

Factory Attached Connectors – For factory made cable assemblies and jumper cables, see pages 584-587.

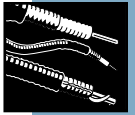

1/2" Superflexible Foam Dielectric, FSJ Series – 50-ohm



FSJ4-50B

Description	Type No.
Cable Ordering Information	
Standard Superflexible Cable	
1/2" Standard Cable, Standard Jacket	FSJ4-50B
Fire Retardant Cables	
1/2" Fire Retardant Jacket (CATVX)	FSJ4RN-50B
1/2" Fire Retardant Jacket (CATVR)	FSJ4RN-50B
Low VSWR and Specialized Cables	
1/2" Low VSWR, specify operating band	FSJ4P-50-(**)
Phase Stabilized and Phase Measured Cable	See page 590
Jumper Cable Assemblies – See page 584	
** Insert suffix number from "Low VSWR Specifications" table, page 487	
Characteristics	
Electrical	
Impedance, ohms	50 ± 1
Maximum Frequency, GHz	10.2
Velocity, percent	81
Peak Power Rating, kW	15.6
dc Resistance, ohms/1000 ft (1000 m)	
Inner	0.82 (2.69)
Outer	1.00 (3.28)
dc Breakdown, volts	2500
Jacket Spark, volts RMS	5000
Capacitance, pF/ft (m)	25.2 (82.7)
Inductance, µH/ft (m)	0.0625 (0.205)
Mechanical	
Outer Conductor	Copper
Inner Conductor	Copper-Clad Aluminum
Diameter over Jacket, standard jacket, in (mm)	0.52 (13.2)
Diameter over Jacket, fire-retardant jacket, in (mm)	0.53 (13.5)
Diameter over Copper Outer Conductor, in (mm)	0.48 (12.2)
Diameter Inner Conductor, in (mm)	0.142 (3.6)
Minimum Bending Radius, in (mm)	1.25 (32)
Number of Bends, minimum (typical)	20 (50)
Bending Moment, lb-ft (N·m)	2.0 (2.7)
Cable Weight, lb/ft. (kg/m)	0.14 (0.21)
Tensile Strength, lb (kg)	175 (80)
Flat Plate Crush Strength, lb/in (kg/mm)	110 (1.9)

Attenuation and Average Power Ratings

Frequency MHz	Attenuation dB/100 ft	Attenuation dB/100 m	Average Power, kW
0.5	0.070	0.231	15.6
1	0.100	0.327	15.6
1.5	0.122	0.401	15.6
2	0.141	0.463	15.6
10	0.318	1.04	10.1
20	0.453	1.49	7.07
30	0.557	1.83	5.75
50	0.724	2.38	4.42
88	0.971	3.19	3.30
100	1.04	3.41	3.08
108	1.08	3.55	2.96
150	1.28	4.21	2.49
174	1.39	4.56	2.30
200	1.50	4.91	2.14
300	1.86	6.09	1.72
400	2.17	7.12	1.48
450	2.31	7.59	1.38
500	2.45	8.04	1.31
512	2.48	8.15	1.29
600	2.71	8.89	1.18
700	2.95	9.68	1.09
800	3.18	10.4	1.01
824	3.23	10.6	0.991
894	3.38	11.1	0.947
960	3.52	11.6	0.909
1000	3.60	11.8	0.889
1250	4.09	13.4	0.783
1500	4.54	14.9	0.705
1700	4.88	16.0	0.656
1800	5.05	16.6	0.634
2000	5.37	17.6	0.597
2100	5.53	18.1	0.580
2200	5.68	18.6	0.564
2300	5.83	19.1	0.549
3000	6.84	22.4	0.469
3400	7.38	24.2	0.435
4000	8.15	26.7	0.394
5000	9.35	30.7	0.343
6000	10.5	34.4	0.306
8000	12.6	41.4	0.254
10000	14.6	47.9	0.220
10200	14.8	48.5	0.217

Standard Conditions:

For attenuation. VSWR 1.0, ambient temperature 20°C (68°F).

For Average Power, VSWR 1.0, ambient temperature 40°C (104°F), inner conductor temperature 100°C (212°F), no solar loading.



N Male
F4PNMV2-H



N Female
Bulkhead
F4PNF-BH



UHF Male
44ASP



N Male
Right Angle
F4PNR-H



7/8" EIA
44ASR



7-16 DIN Female
F4PDF-C



7-16 DIN Male
F4PDMV2-C

Connectors

Interface	Description	Type Number	Inner Contact Attachment	Outer Contact Attachment	Plating Code	Max. Length in (mm)	Max. Dia. in (mm)
N Male	Hex Head	F4PNMV2-H	Solder	Crush-Flare	SG	2.13 (54.0)	0.94 (23.8)
N Male	Hex Head	F4PNMV2-HC	Captivated	Crush-Flare	SG	2.13 (54.0)	0.94 (23.8)
N Male	Rt Angle, Hex Hd	F4PNR-H	Solder	Tab-Flare	SG	3.3/1.5 (84/38)	0.86 (21.8)
N Male		F4PNR-HC	Captivated	Crush-Flare	SG	2.8 (71.9)/1.6 (41.5)	1 (25.7)
N Female	–	F4PNF	Solder	Self-Flare	SG	2.3 (53.3)	0.88 (22.4)
N Female	–	F4PNF-C	Captivated	Self-Flare	SG	2.3 (53.3)	0.88 (22.4)
N Female	Bulkhead	F4PNF-BH	Solder	Self-Flare	SG	2.3 (50)	0.95 (24.1)
4.1/9.5 DIN Male	–	F4PKM-C	Captivated	Self-Flare	SS	2.0 (50)	0.95 (24.1)
4.1/9.5 DIN Male	Rt Angle, Outdoor Use	F4PKR-C	Captivated	Self-Flare	SS	2.3/1.5 (57/38)	0.95 (24.1)
7-16 DIN Male	–	F4PDMV2-C	Captivated	Crush Flare	SG	1.98 (50.2)	1.05 (26.7)
7-16 DIN Male	–	F4PDMV2	Solder	Crush Flare	SS	2.10 (53.4)	1.05 (26.7)
7-16 DIN Male	Right Angle	F4PDR	Solder	Self-Flare	SS	2.4.1.8 (61/46)	1.4 (35.6)
7-16 DIN Male	Right Angle	F4PDR-C	Captivated	Self-Flare	SS	2.1/2.0 (53/50)	1.4 (35.6)
7-16 DIN Female	–	F4PDF-C	Captivated	Self-Flare	SS	2.0 (50)	1.1 (27.9)
7-16 DIN Female	–	F4PDF	Solder	Self-Flare	SS	2.0 (50)	1.1 (27.9)
7-16 DIN Female	Bulkhead	F4PDF-BH	Solder	Self-Flare	SS	2.01 (51.1)	1.50 (38)
7-16 DIN Female	Panel Mount	F4PDF-PM	Solder	Self-Flare	SS	2.01 (51.1)	1.26 (32)
7-16 DIN Female	Bulkhead	F4PDF-BHC	Captivated	Self-Flare	SS	2.0 (50)	1.8 (45.7)
7-16 DIN Female	Panel Mount	F4PDF-PMC	Captivated	Self-Flare	SS	2.0 (50)	1.3 (33)
7/8" EIA Flange	–	44ASR	Solder	Tab-Flare	BS	3.3 (84)	1.4 (35.6)
UHF Male	–	44ASP	Solder	Tab-Flare	BS	2.1 (53)	0.84 (21.3)
UHF Female	–	44ASU	Solder	Tab-Flare	BS	2.3 (58)	0.84 (21.3)
HN Male	–	44ASJ	Solder	Tab-Flare	BB	2.4 (61)	0.84 (21.3)
SC Male	–	44SPCW	Solder	Tab-Flare	SG	2.7 (69)	0.88 (22.4)

Plating Codes: BB - Brass Body and Pin, BS - Brass Body and Silver Plated Pin, SG - Silver Plated Body and Gold Plated Pin, SS - Silver Plated Body and Pin

Connector Accessories – See page 624

Factory Attached Connectors – For factory made cable assemblies and jumper cables, see pages 584-587.

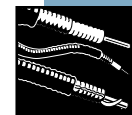

Low VSWR Specifications, Type FSJ4P-50B-(-)

Frequency Band, GHz	Type No.	Using Connector Type**	Assembly VSWR, Maximum (R.L., dB)			
			0-10 ft (0-3 m)	10-20 ft (3-6 m)	20-100 ft (6-30 m)	Above 100 ft (Above 30 m)
0.01-2.3*	FSJ4P-50B-1	N Male	1.10 (26.4)	1.10 (26.4)	1.15 (23.1)	1.15 (23.1)
		N Female	1.15 (23.1)	1.15 (23.1)	1.15 (23.1)	1.20 (20.8)
		7-16 DIN Male	1.15 (23.1)	1.15 (23.1)	1.15 (23.1)	1.20 (20.8)
		7-16 DIN Female	1.15 (23.1)	1.15 (23.1)	1.15 (23.1)	1.20 (20.8)
		Rt. Angle N Male	1.15 (23.1)	1.18 (21.6)	1.30 (17.7)	1.50 (14.0)
0.01-4.2*	FSJ4P-50B-2	N Male	1.20 (20.8)	1.20 (20.8)	1.20 (20.8)	1.20 (20.8)
		N Female	1.25 (19.1)	1.25 (19.1)	1.25 (19.1)	1.30 (17.7)
		7-16 DIN Male	1.25 (19.1)	1.25 (19.1)	1.25 (19.1)	1.30 (17.7)
		7-16 DIN Female	1.25 (19.1)	1.25 (19.1)	1.25 (19.1)	1.30 (17.7)
		Rt. Angle N Male	1.35 (16.5)	1.35 (16.5)	1.35 (16.5)	1.50 (14.0)
0.01-7.1*	FSJ4P-50B-3	N Male	1.35 (16.5)	1.35 (16.5)	1.35 (16.5)	1.35 (16.5)
		N Female	1.35 (16.5)	1.35 (16.5)	1.40 (15.6)	1.50 (14.0)
		7-16 DIN Male	1.35 (16.5)	1.35 (16.5)	1.40 (15.6)	1.50 (14.0)
		7-16 DIN Female	1.35 (16.5)	1.35 (16.5)	1.40 (15.6)	1.50 (14.0)
0.806-0.960	FSJ4P-50B-40	N	1.08 (28.3)	1.10 (26.4)	1.10 (26.4)	-
		7-16 DIN	1.08 (28.3)	1.10 (26.4)	1.10 (26.4)	-
0.806-0.960 and 1.7- 2.3	FSJ4P-50B-42	N	1.10 (26.4)	1.10 (26.4)	1.10 (26.4)	-
		7-16 DIN	1.10 (26.4)	1.10 (26.4)	1.10 (26.4)	-
1.7- 2.3	FSJ4P-50B-41	N	1.10 (26.4)	1.10 (26.4)	1.10 (26.4)	-
		7-16 DIN	1.10 (26.4)	1.10 (26.4)	1.10 (26.4)	-
0.3-1.7	FSJ4P-50B-6	N Male	1.15 (23.1)	1.15 (23.1)	1.15 (23.1)	1.20 (20.8)
		N Female	1.15 (23.1)	1.15 (23.1)	1.15 (23.1)	1.20 (20.8)
		7-16 DIN Male	1.15 (23.1)	1.15 (23.1)	1.15 (23.1)	1.20 (20.8)
		7-16 DIN Female	1.15 (23.1)	1.15 (23.1)	1.15 (23.1)	1.20 (20.8)
		Rt. Angle N Male	1.20 (20.8)	1.20 (20.8)	1.30 (17.7)	1.40 (15.6)
1.7-2.7	FSJ4P-50B-7	N Male	1.15 (23.1)	1.15 (23.1)	1.15 (23.1)	1.20 (20.8)
		N Female	1.15 (23.1)	1.15 (23.1)	1.15 (23.1)	1.20 (20.8)
		7-16 DIN Male	1.15 (23.1)	1.15 (23.1)	1.15 (23.1)	1.20 (20.8)
		7-16 DIN Female	1.15 (23.1)	1.15 (23.1)	1.15 (23.1)	1.20 (20.8)
		Rt. Angle N Male	1.20 (20.8)	1.20 (20.8)	1.20 (20.8)	1.20 (20.8)
4.0-8.0*	FSJ4P-50B-8	N Male	1.35 (16.5)	1.35 (16.5)	1.35 (16.5)	1.40 (15.6)
		N Female	1.50 (14.0)	1.50 (14.0)	1.50 (14.0)	1.40 (15.6)
		7-16 DIN Male	1.50 (14.0)	1.50 (14.0)	1.50 (14.0)	1.40 (15.6)
		7-16 DIN Female	1.50 (14.0)	1.50 (14.0)	1.50 (14.0)	1.40 (15.6)

* Specify operating band. ** Connectors ordered separately.

VSWR values apply to straight connectors only (except where noted otherwise), are guaranteed for factory fit assemblies and are typical for field cut lengths. If two different connector interfaces are selected, the higher VSWR value is guaranteed.



Accessories

Description	Type No.
Hangers – For more hangers, adapters and mounting hardware see pages 599-607	
Standard Hangers Kit of 10. Recommended maximum spacing is 3-ft (1 m). For different spacing recommendations, refer to Cable Hanger Spacing, page 593-598	43211A
Snap-in Hangers Kit of 10. For prepunched 3/4" (19mm) holes on tower member or adapters, Recommended maximum spacing is 3-ft (1 m). For different spacing recommendations, refer to Cable Hanger Spacing, page 593-598	206706A-1
Support/Hoisting Grip. Use at 200-ft (60m) intervals.	
Grip with one clamp	F4SGRIP
Support clamp kit of 10	F4SGRIP-4IK
Standard Hoisting Grip	43094
Grounding and Surge Protection – for additional grounding kits and our surge protection offerings, see pages 609-616	
Standard Grounding Kits	
Factory attached one-hole lug 24"	204989-1
Factory attached two-hole lug 24"	241088-1
Field attached one-hole lug 36"	204989-21
Field attached two-hole lug 36"	241088-6

Description	Type No.
Weatherproofing – for additional weatherproofing information see pages 617-618	
WeatherShield™ Connector Protection Housing	
LDF5 to FSJ4	WS-L5F4
LDF6 to FSJ4	WS-L6F4
LDF7 to FSJ4	WS-L7F4
Cold Shrink Weatherproofing Kit	
1/2" Coax N Connector to 1/2" Coax N Connector	241474-4
5/8" Coax to 1/2" Coax	241475-13
7/8" Coax to 1/2" Coax	241475-9
1-1/4" or 1-5/8" Coax to 1/2" Coax	241475-5A
2-1/4" Coax to 1/2" Coax	241475-8
1/2" to 1-1/2" Omni/Panel base Type N or DIN	241548-8
Connector/Splice Weatherproofing Kit	221213

Entry Systems – For entry systems offerings see pages 619-620

Standard Cable Entry Boots	4" Boots	5" Boots
One Hole:	204679A-5	48939A-6
Three Hole:	204679A-7	48939A-8
Four Hole	204679A-16	48939A-17

Tools – for additional tool offerings see pages 620-623

EASIA [®] Plus Automated Cable Prep Tool (V2 connectors only)	CPT-F4B
EASIA [®] Cutting Tool FSJ4/FSJ1	207865
EASIA [®] Cutting Tool FSJ4/FSJ2	241372
Cable Flare Tool	224363
DIN Connector Coupling Torque Wrench	244377
N Connector Coupling Torque Wrench	244379

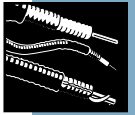

3/8" Extraflexible Foam Dielectric, EFX Series – 50-ohm



EFX2-50

Description	Type No.
-------------	----------

Cable Ordering Information

Extraflexible Cable	
3/8" Extraflexible Cable, Standard Jacket	EFX2-50
Fire Retardant Cables	
3/8" Fire Retardant Jacket (CATVX)	EFX2RN-50
3/8" Fire Retardant Jacket (CATVR)	EFX2RN-50
Low VSWR Cables	EFX2P-50-(**)
Jumper Cable Assemblies – See page 584	

** Insert suffix number from "Low VSWR Specifications" table, page 490

Characteristics

Electrical	
Impedance, ohms	50 ± 1
Maximum Frequency, GHz	13.5
Velocity, percent	85
Peak Power Rating, kW	15.6
dc Resistance, ohms/1000 ft (1000 m)	
Inner	1.1 (3.6)
Outer	0.92 (3.0)
dc Breakdown, volts	2500
Jacket Spark, volts RMS	5000
Capacitance, pF/ft (m)	24.1 (79.0)
Inductance, µH/ft (m)	0.06 (0.20)
Mechanical	
Outer Conductor	Copper
Inner Conductor	Copper-Clad Aluminum
Diameter over Jacket, in (mm)	0.45 (11.3)
Diameter over Copper Outer Conductor, in (mm)	0.38 (9.7)
Minimum Bending Radius, in (mm)	1.75 (45)
Number of Bends, minimum (typical)	15
Bending Moment, lb-ft (N·m)	1.7 (2.3)
Cable Weight, lb/ft (kg/m)	0.09 (0.13)
Tensile Strength, lb (kg)	175 (79)
Flat Plate Crush Strength, lb/in (kg/mm)	120 (2.1)

Attenuation and Average Power Ratings

Frequency MHz	Attenuation dB/100 ft	Attenuation dB/100 m	Average Power, kW
0.5	0.074	0.244	15.6
1	0.105	0.345	15.6
1.5	0.129	0.423	15.6
2	0.149	0.488	15.6
10	0.335	1.10	6.97
20	0.476	1.56	4.90
30	0.584	1.92	3.99
50	0.759	2.49	3.07
88	1.01	3.33	2.30
100	1.08	3.56	2.15
108	1.13	3.70	2.07
150	1.34	4.39	1.74
174	1.44	4.74	1.61
200	1.55	5.10	1.50
300	1.92	6.31	1.21
400	2.24	7.35	1.04
450	2.39	7.83	0.978
500	2.52	8.28	0.924
512	2.56	8.39	0.913
600	2.78	9.13	0.838
700	3.03	9.93	0.771
800	3.25	10.7	0.717
824	3.31	10.8	0.706
894	3.46	11.3	0.675
960	3.59	11.8	0.649
1000	3.68	12.1	0.635
1250	4.16	13.6	0.561
1500	4.60	15.1	0.507
1700	4.94	16.2	0.473
1800	5.10	16.7	0.458
2000	5.41	17.8	0.431
2100	5.57	18.3	0.419
2200	5.71	18.7	0.408
2300	5.86	19.2	0.398
3000	6.83	22.4	0.342
3400	7.35	24.1	0.318
4000	8.08	26.5	0.289
5000	9.23	30.3	0.253
6000	10.3	33.8	0.227
8000	12.3	40.3	0.190
10000	14.1	46.3	0.165
12000	15.9	52.0	0.147
13500	17.1	56.1	0.137

Standard Conditions:

For attenuation, VSWR 1.0, ambient temperature 20°C (68°F).

For Average Power, VSWR 1.0, ambient temperature 40°C (104°F), inner conductor temperature 100°C (212°F), no solar loading.



E2PNM-H
N Male



E2PNR-HC
N Male Right Angle

Connectors

Interface	Description	Type Number	Inner Contact Attachment	Outer Contact Attachment	Plating Code	Max. Length in (mm)	Max. Dia. in (mm)
N Male	-	E2PNM-C	Captivated	Self-Flare	SG	-	-
N Male	Hex Head	E2PNM-H	Solder	Self-Flare	SG	2.0 (52)	0.94 (23.9)
N Male	-	E2PNM-HC	Captivated	Self-Flare	SG	2.16 (54.8)/0.89 (17.6)	0.89 (17.6)
N Male	Right Angle	E2PNR-HC	Captivated	Self-Flare	SG	2.4/1.5 (60.4/37.7)	0.91 (23.1)
N Female	-	E2PNF-C	Captivated	Self-Flare	SG	-	-
N Female	-	E2PNF	Solder	Self-Flare	SG	2.4 (61)	0.69 (17.6)
N Female	Bulkhead	E2PNF-BH	Solder	Self-Flare	SG	2.5 (63.7)	0.86 (21.4)
7-16 DIN Male	-	E2PDM-C	Captivated	Self-Flare	SS	2.1 (53)	1.41 (35.9)
7-16 DIN Male	Right Angle	E2PDR-C	Captivated	Self-Flare	SS	2.9 (74.4)/45.5 (1.8)	1.4 (35.9)
7-16 DIN Female	-	E2PDF-C	Captivated	Self-Flare	SS	2.1 (53)	1.10 (27.9)
TNC Male	-	E2PTM	Solder	Self-Flare	SG	2.2 (56)	0.63 (16.1)
TNC Female	-	E2PTF	Solder	Self-Flare	NG	1.9 (49)	0.63 (16.1)
UHF Male	-	E2UM	Solder	Self-Flare	BB	2.2 (56)	0.77 (19.6)
UHF Female	-	E2UF	Solder	Self-Flare	BS	2.1 (53)	0.68 (17.3)
SMA Male	-	E2SM	Solder	Self-Flare	BG	2.2 (56)	0.68 (17.3)

Plating Codes: BG - Brass Body and Gold Plated Pin, BS - Brass Body and Silver Plated Pin, NG - Nickel Plated Body and Gold Plated Pin, SG - Silver Plated Body and Gold Plated Pin, SS - Silver Plated Body and Pin

Low VSWR Specifications, Type EFX2P-50(-)

Frequency Band, GHz	Type No.	Using Connector Type**	Assembly VSWR, Maximum (R.L., dB)	
			0-10 ft (0-3 m)	10-20 ft (3-6 m)
0.806-0.960	EFX2P-50-40	N 7-16 DIN	1.08 (28.3)	1.10 (26.4)
			1.08 (28.3)	1.10 (26.4)
0.806-0.960 and 1.7- 2.3	EFX2P-50-42	N 7-16 DIN	1.10 (26.4)	1.10 (26.4)
			1.10 (26.4)	1.10 (26.4)
1.7- 2.3	EFX2P-50-41	N 7-16 DIN	1.10 (26.4)	1.10 (26.4)
			1.10 (26.4)	1.10 (26.4)

**Connectors ordered separately. VSWR values apply to straight connectors only, are guaranteed for factory fit assemblies, and are typical for cut lengths. If two different connector interfaces are selected, the higher VSWR value is guaranteed.

Accessories

Description	Type No.
Hangers – For more hangers, adapters and mounting hardware see pages 599-607	
Insulated Hanger , single. Recommended maximum spacing is 2.5 ft (0.76 m). For different spacing recommendations, refer to Cable Hanger Spacing, page 593-598	11662-3
Support/Hoisting Grip . Use at 200-ft (60m) intervals.	
Grip with one clamp	E2SGRIP
Support clamp kit of 10	E2SGRIP-2IK
Grounding and Surge Protection – for additional grounding kits and our surge protection offerings, see pages 609-616	
Standard Grounding Kit	
Factory attached one-hole lug, 24" lead	223158
Factory attached two-hole lug, 24" lead	223158-2
Field attached one-hole lug, 36" lead	223158-3

Connector Accessories – See page 624

Factory Attached Connectors – For factory made cable assemblies and jumper cables, see pages 584-587.

Description	Type No.
Weatherproofing – for additional weatherproofing information see pages 617-618	
Cold Shrink Weatherproofing Kit	
3/8" Coax to 3/8" Coax with N Connector	241475-10
5/8" Coax to 3/8" Coax	241475-13
7/8" Coax to 3/8" Coax	241475-9
1-1/4" or 1-5/8" Coax to 3/8" Coax	241475-5A
2 1/4" Coax to 3/8" Coax	241475-8
3/8" Coax to 1-1/2" Omni Panel Base type N or DIN	241548-8
3/8" Coax to 2" Omni Panel Base type N or DIN	241548-9
Connector/Splice Weatherproofing Kit	221213
Entry Systems – For entry systems offerings see pages 619-620	
Standard Cable Entry Boots	
4" Boots – Three Hole:	204679A-19
5" Boots – One Hole:	48939A-16

Tools – for additional tool offerings see pages 620-623

EASIX [®] Plus Automated Cable Prep Tool for:	
DIN Connectors	CPT-E2L2DIN
N Connectors	CPT-E2L2N
DIN Connector Coupling Torque Wrench	244377
N Connector Coupling Torque Wrench	244379

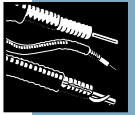

1/4" Foam Dielectric, LDF Series – 50-ohm



LDF1-50

Description	Type No.
Cable Ordering Information	
Standard Cable	
1/4" Standard Cable, Standard Jacket	LDF1-50
Fire Retardant Cables	
1/4" Fire Retardant Jacket (CATVX)	LDF1RN-50
1/4" Fire Retardant Jacket (CATVR)	LDF1RN-50
Jumper Cable Assemblies – See page 584	

Characteristics

Electrical	
Impedance, ohms	50 ± 1
Maximum Frequency, GHz	15.8
Velocity, percent	86
Peak Power Rating, kW	12.1
dc Resistance, ohms/1000 ft (1000 m)	
Inner	1.57 (5.15)
Outer	1.02 (3.33)
dc Breakdown, volts	2200
Jacket Spark, volts RMS	5000
Capacitance, pF/ft (m)	23.4 (76.8)
Inductance, µH/ft (m)	0.059 (0.19)
Mechanical	
Outer Conductor	Copper
Inner Conductor	Copper-Clad Aluminum
Diameter over Jacket, in (mm)	0.345 (8.8)
Diameter over Copper Outer Conductor, in (mm)	0.31 (7.7)
Diameter Inner Conductor, in (mm)	0.102 (2.6)
Minimum Bending Radius, in (mm)	3.0 (76)
Number of Bends, minimum (typical)	15 (30)
Bending Moment, lb-ft (N·m)	0.98 (1.33)
Cable Weight, lb/ft (kg/m)	0.06 (0.09)
Tensile Strength, lb (kg)	200 (91)
Flat Plate Crush Strength, lb/in (kg/mm)	80 (1.4)

Attenuation and Average Power Ratings

Frequency MHz	Attenuation dB/100 ft	Attenuation dB/100 m	Average Power, kW
0.5	0.085	0.278	12.1
1	0.120	0.394	12.1
1.5	0.147	0.483	12.1
2	0.170	0.558	12.1
10	0.382	1.25	5.79
20	0.543	1.78	4.08
30	0.667	2.19	3.32
50	0.865	2.84	2.56
88	1.16	3.79	1.92
100	1.23	4.05	1.79
108	1.28	4.21	1.72
150	1.52	4.99	1.45
174	1.64	5.39	1.35
200	1.77	5.80	1.25
300	2.18	7.17	1.01
400	2.54	8.34	0.871
450	2.71	8.88	0.818
500	2.86	9.39	0.773
512	2.90	9.51	0.764
600	3.15	10.4	0.702
700	3.43	11.2	0.646
800	3.68	12.1	0.601
824	3.74	12.3	0.592
894	3.91	12.8	0.566
960	4.07	13.3	0.545
1000	4.16	13.6	0.533
1250	4.70	15.4	0.471
1500	5.19	17.0	0.426
1700	5.57	18.3	0.398
1800	5.75	18.9	0.385
2000	6.10	20.0	0.363
2100	6.27	20.6	0.353
2200	6.43	21.1	0.344
2300	6.60	21.6	0.336
3000	7.67	25.2	0.289
3400	8.24	27.0	0.269
4000	9.06	29.7	0.245
5000	10.3	33.9	0.215
6000	11.5	37.7	0.193
8000	13.7	44.9	0.162
10000	15.7	51.5	0.141
12000	17.6	57.7	0.126
14000	19.4	63.5	0.114
15800	20.9	68.6	0.106

Standard Conditions:

For attenuation. VSWR 1.0, ambient temperature 20°C (68°F).

For Average Power, VSWR 1.0, ambient temperature 40°C (104°F), inner conductor temperature 100°C (212°F), no solar loading.



N Male
L1PNR-HC



N Male
L1PNM-H



N Female
L1PNF

Connectors

Interface	Description	Type Number	Inner Contact Attachment	Outer Contact Attachment	Plating Code	Max. Length in (mm)	Max. Dia. in (mm)
N Male	Hex Head	L1PNM-H	Solder	Self-Flare	SG	1.9 (49)	0.94 (23.9)
N Male	Hex Head	L1PNM-HC	Captivated	Self-Flare	SS	2 (52)	0.89 (17.6)
N Male	Right Angle	L1PNR-HC	Captivated	Self-Flare	SG	2.3/1.3 (58.3/32.7)	0.91 (23.1)
N Female		L1PNF	Solder	Self-Flare	SG	2.1 (52)	0.62 (15.7)
N Female		L1PNF-C	Captivated	Self-Flare	SG	-	-
N Female	Bulkhead	L1PNF-BH	Solder	Self-Flare	SG	2.1 (52)	0.88 (22.4)

Plating Codes: SG - Silver Plated Body and Gold Plated Pin

Low VSWR Specifications, Type LDF1P-50(-)

Frequency Band, GHz	Type No.	Using Connector Type**	Assembly VSWR, Maximum (R.L., dB)	
			0-10 ft (0-3 m)	10-20 ft (3-6 m)
0.806-0.960	LDF1P-50-40	N	1.08 (28.3)	1.10 (26.4)
		7-16 DIN	1.08 (28.3)	1.10 (26.4)
0.806-0.960 and 1.7- 2.3	LDF1P-50-42	N	1.10 (26.4)	1.10 (26.4)
		7-16 DIN	1.10 (26.4)	1.10 (26.4)
1.7- 2.3	LDF1P-50-41	N	1.10 (26.4)	1.10 (26.4)
		7-16 DIN	1.10 (26.4)	1.10 (26.4)

**Connectors ordered separately. VSWR values apply to straight connectors only, are guaranteed for factory fit assemblies, and are typical for cut lengths. If two different connector interfaces are selected, the higher VSWR value is guaranteed.

Accessories

Description	Type No.
Hangers – For more hangers, adapters and mounting hardware see pages 599-607	
Insulated Hanger , single. Recommended maximum spacing is 2.5 ft (0.76 m). For different spacing recommendations, refer to Cable Hanger Spacing, page 593-598	11662-3
Angle Adapter , for insulated hanger	40430-1
Nylon Cable Tie Kit of 50, Indoor use, Recommended maximum spacing is 1.5 ft (0.5 m)	40417
Nylon Cable Tie Kit in plastic box. 100 each 4, 5.5 and 7.5 inch ties. Indoor use, Recommended maximum spacing is 1.5 ft (0.5 m)	CT-K350
Velcro Cable Ties , Black, 8 inch. Indoor Use	
Kit of 10	VCT8-10
Kit of 50	VCT8-50
Kit of 100	VCT8-100
Support/Hoisting Grip . Use at 200-ft (60m) intervals.	
Grip with one clamp	L1SGRIP
Support clamp kit of 10	L1SGRIP-11K

Connector Accessories – See page 624

Factory Attached Connectors – For factory made cable assemblies and jumper cables, see pages 584-587.

Description	Type No.
Grounding and Surge Protection – for additional grounding kits and our surge protection offerings, see pages 609-616	
Standard Grounding Kit	
Factory attached one-hole lug, 24" lead	223158
Factory attached two-hole lug, 24" lead	223158-2
Field attached one-hole lug, 36" lead	223158-3
Weatherproofing – for additional weatherproofing information see pages 617-618	
Cold Shrink Weatherproofing Kit	
5/8" Coax to 1/4" Coax	241475-13
7/8" Coax to 1/4" Coax	241475-12
1-1/4" or 1-5/8" Coax to 1/4" Coax	241475-11
1/4" to 1-1/2" Omni/Panel base Type N or DIN	241548-10
1/4" to 2" Omni/Panel base Type N or DIN	241548-11
Connector/Splice Weatherproofing Kit	221213
Entry Systems – For entry systems offerings see pages 619-620	
Standard Cable Entry Boots	
4" Boots – Three Hole:	204679A-17
Tools – for additional tool offerings see pages 620-623	
EASIX® Plus Automated Cable Prep Tool	CPT-L1
DIN Connector Coupling Torque Wrench	244377
N Connector Coupling Torque Wrench	244379

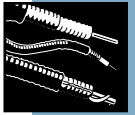

3/8" Foam Dielectric, LDF Series – 50-ohm



LDF2-50

Description	Type No.
-------------	----------

Cable Ordering Information

Standard Cable	
3/8" Standard Cable, Standard Jacket	LDF2-50
Fire Retardant Cables	
3/8" Fire Retardant Jacket (CATVX)	LDF2RN-50
3/8" Fire Retardant Jacket (CATVR)	LDF2RN-50
Low VSWR and Specialized Cables	
3/8" Low VSWR, specify operating band	LDF2P-50-(**)
Phase Stabilized and Phase Measured Cable	See page 590
Jumper Cable Assemblies – See page 584	

** Insert suffix number from "Low VSWR Specifications" table, page 495

Characteristics

Electrical	
Impedance, ohms	50 ± 1
Maximum Frequency, GHz	13.5
Velocity, percent	88
Peak Power Rating, kW	15.6
dc Resistance, ohms/1000 ft (1000 m)	
Inner	1.06 (3.48)
Outer	0.87 (2.85)
dc Breakdown, volts	2500
Jacket Spark, volts RMS	5000
Capacitance, pF/ft (m)	23.0 (75.5)
Inductance, µH/ft (m)	0.058 (0.19)
Mechanical	
Outer Conductor	Copper
Inner Conductor	Copper-Clad Aluminum
Diameter over Jacket, in (mm)	0.44 (11)
Diameter over Copper Outer Conductor, in (mm)	0.38 (9.7)
Diameter Inner Conductor, in (mm)	0.122 (3.1)
Minimum Bending Radius, in (mm)	3.75 (95)
Number of Bends, minimum (typical)	15 (60)
Bending Moment, lb-ft (N·m)	1.4 (1.9)
Cable Weight, lb/ft (kg/m)	0.08 (0.12)
Tensile Strength, lb (kg)	250 (113)
Flat Plate Crush Strength, lb/in (kg/mm)	110 (2.0)

Attenuation and Average Power Ratings

Frequency MHz	Attenuation dB/100 ft	Attenuation dB/100 m	Average Power, kW
0.5	0.072	0.235	15.6
1	0.101	0.332	15.6
1.5	0.124	0.407	15.6
2	0.143	0.471	15.6
10	0.323	1.06	7.23
20	0.458	1.50	5.09
30	0.563	1.85	4.14
50	0.730	2.40	3.19
88	0.976	3.20	2.39
100	1.04	3.42	2.24
108	1.08	3.56	2.15
150	1.29	4.22	1.81
174	1.39	4.56	1.68
200	1.49	4.90	1.56
300	1.85	6.06	1.26
400	2.15	7.06	1.08
450	2.29	7.51	1.02
500	2.42	7.95	0.963
512	2.45	8.05	0.951
600	2.67	8.76	0.874
700	2.90	9.52	0.804
800	3.12	10.2	0.748
824	3.17	10.4	0.736
894	3.31	10.9	0.704
960	3.44	11.3	0.678
1000	3.52	11.6	0.663
1250	3.98	13.1	0.586
1500	4.40	14.4	0.530
1700	4.72	15.5	0.494
1800	4.87	16.0	0.479
2000	5.17	17.0	0.451
2100	5.32	17.4	0.439
2200	5.46	17.9	0.428
2300	5.60	18.4	0.417
3000	6.52	21.4	0.358
3400	7.00	23.0	0.333
4000	7.70	25.3	0.303
5000	8.78	28.8	0.266
6000	9.79	32.1	0.239
8000	11.7	38.2	0.200
10000	13.4	43.9	0.175
12000	15.0	49.2	0.156
13500	16.2	53.0	0.145

Standard Conditions:

For attenuation, VSWR 1.0, ambient temperature 20°C (68°F).

For Average Power, VSWR 1.0, ambient temperature 40°C (104°F), inner conductor temperature 100°C (212°F), no solar loading.

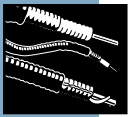

N Male
L2PNM-H



N Female
L2PNF



7-16 DIN Male
L2PDM-C



UHF Male
L42P



TNC Male
L2PTM



SMA Male
L42WS

Connectors

Interface	Description	Type Number	Inner Contact Attachment	Outer Contact Attachment	Plating Code	Max. Length in (mm)	Max. Dia. in (mm)
N Male	Hex Head	L2PNM-H	Solder	Self-Flare	SG	2.1 (53)	0.94 (23.9)
N Male	Hex Head	L2PNM-HC	Captivated	Self-Flare	SG	2.1 (53)	0.94 (23.9)
N Female	–	L2PNF	Solder	Self-Flare	SG	2.4 (61)	0.63 (16.0)
N Female	Bulk Head	L2PNF-BH	Solder	Self-Flare	SG	2.4 (61)	0.88 (22.4)
4.1/9.5 DIN	–	L2PKM-C	Captivated	Self-Flare	SS	1.9 (48)	0.95 (24.1)
4.1/9.5 DIN	–	L2PKM	Solder	Self-Flare	SS	1.9 (48)	0.95 (24.1)
4.1/9.5 DIN	Right Angle	L2PKR-C	Captivated	Self-Flare	SS	2.0/1.5 (50/38)	0.95 (24.1)
7-16 DIN Male	–	L2PDM-C	Captivated	Self-Flare	SS	1.9 (48)	1.1 (27.9)
7-16 DIN Female	–	L2PDF-C	Captivated	Self-Flare	SS	1.9 (48)	1.4 (35.6)
7-16 DIN Female	Panel Mount	L2PDF-PMC	Captivated	Self-Flare	SS	1.9 (48)	1.25 (31.8)
UHF Male	–	L42P	Solder	Self-Flare	BB	2.3 (58)	0.68 (17.3)
UHF Female	–	L42U	Solder	Self-Flare	BB	2.3 (58)	0.91 (23.1)
SMA Male	–	L42WS	Solder	Self-Flare	BG	2.2 (56)	0.68 (17.3)
TNC Male	–	L42EWT	Solder	Self-Flare	NG	2.1 (53)	0.68 (17.3)
TNC Female	–	L42ENT	Solder	Self-Flare	NG	1.9 (48)	0.68 (17.3)

Plating Codes: BB - Brass Body and Pin, BS - Brass Body and Silver Plated Pin, NG - Nickel Plated Body and Gold Plated Pin, SG - Silver Plated Body and Gold Plated Pin, SS - Silver Plated Body and Pin

Connector Accessories – See page 624

Factory Attached Connectors – For factory made cable assemblies and jumper cables, see pages 584-587.

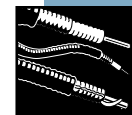

Low VSWR Specifications, Type LDF2P-50-()

Frequency Band, GHz	Type No.	Using Connector Type**	Assembly VSWR, Maximum (R.L., dB)	
			0-10 ft (0-3 m)	10-20 ft (3-6 m)
0.806-0.960	LDF2P-50-40	N	1.08 (28.3)	1.10 (26.4)
		7-16 DIN	1.08 (28.3)	1.10 (26.4)
0.806-0.960 and 1.7- 2.3	LDF2P-50-42	N	1.10 (26.4)	1.10 (26.4)
		7-16 DIN	1.10 (26.4)	1.10 (26.4)
1.7- 2.3	LDF2P-50-41	N	1.10 (26.4)	1.10 (26.4)
		7-16 DIN	1.10 (26.4)	1.10 (26.4)
Up to 2.3 *	LDF2P-50-1	N Male	1.15 (23.1)	1.20 (20.8)
		N Female	1.15 (23.1)	1.25 (19.9)
		TNC Male	1.20 (20.8)	1.30 (17.7)
Up to 4.2 *	LDF2P-50-2	N Male	1.20 (20.8)	1.35 (16.6)
		N Female	1.35 (16.6)	1.45 (14.7)
Up to 8.5 *	LDF2P-50-3	N Male	1.25 (19.9)	1.35 (16.6)
Up to 13.5 *	LDF2P-50-4	N Male: L2PNM	1.30 (17.7)	1.35 (16.6)

* Specify operating band. ** Connectors ordered separately.

VSWR values apply to straight connectors only, are guaranteed for factory fit assemblies, and are typical for cut lengths. If two different connector interfaces are selected, the higher VSWR value is guaranteed.

Accessories

Description	Type No.
Hangers – For more hangers, adapters and mounting hardware see pages 599-607	
Insulated Hanger , single. Recommended maximum spacing is 2.5 ft (0.76 m). For different spacing recommendations, refer to Cable Hanger Spacing, page 593-598	11662-3
Angle Adapter , for insulated hanger	40430-1
Nylon Cable Tie Kit of 50, Indoor use, Recommended maximum spacing is 1.5 ft (0.5 m)	40417
Nylon Cable Tie Kit in plastic box. 100 each 4, 5.5 and 7.5 inch ties. Indoor use, Recommended maximum spacing is 1.5 ft (0.5 m)	CT-K350
Velcro Cable Ties, Black, 8 inch. Indoor Use	
Kit of 10	VCT8-10
Kit of 50	VCT8-50
Kit of 100	VCT8-100
Support/Hoisting Grip . Use at 200-ft (60m) intervals.	
Grip with one clamp	L2SGRIP
Support clamp kit of 10	L2SGRIP-2IK
Grounding and Surge Protection – for additional grounding kits and our surge protection offerings, see pages 609-616	
Standard Grounding Kit	
Factory attached one-hole lug, 24" lead	223158
Factory attached two-hole lug, 24" lead	223158-2
Field attached one-hole lug, 36" lead	223158-3

Description	Type No.
Weatherproofing – for additional weatherproofing information see pages 617-618	
Cold Shrink Weatherproofing Kit	
3/8" Coax to 3/8" Coax with N Connector	241475-10
5/8" Coax to 3/8" Coax	241475-13
7/8" Coax to 3/8" Coax	241475-9
1-1/4" or 1-5/8" Coax to 3/8" Coax	241475-5A
2 1/4" Coax to 3/8" Coax	241475-8
3/8" Coax to 1-1/2" Omni Panel Base type N or DIN	241548-8
3/8" Coax to 2" Omni Panel Base type N or DIN	241548-9
Connector/Splice Weatherproofing Kit	221213
Entry Systems – For entry systems offerings see pages 619-620	
Standard Cable Entry Boots	
4" Boots – Three Hole:	204679A-19
5" Boots – One Hole:	48939A-16
Tools – for additional tool offerings see pages 620-623	
EASIAx [®] Plus Automated Cable Prep Tool for:	
DIN Connectors	CPT-E2L2DIN
N Connectors	CPT-E2L2N
DIN Connector Coupling Torque Wrench	244377
N Connector Coupling Torque Wrench	244379



1/2" Foam Dielectric, LDF Series – 50-ohm



LDF4-50A

Description	Type No.
Cable Ordering Information	
Standard Cable	
1/2" Standard Cable, Standard Jacket	LDF4-50A
Fire Retardant Cables	
1/2" Fire Retardant Jacket (CATVX)	LDF4RN-50A
1/2" Fire Retardant Jacket (CATVR)	LDF4RN-50A
Low VSWR and Specialized Cables	
1/2" Low VSWR, specify operating band	LDF4P-50A-(**)
Phase Stabilized and Phase Measured Cable	See page 590
Jumper Cable Assemblies – See page 584	
** Insert suffix number from "Low VSWR Specifications" table, page 498	
Characteristics	
Electrical	
Impedance, ohms	50 ± 1
Maximum Frequency, GHz	8.8
Velocity, percent	88
Peak Power Rating, kW	40
dc Resistance, ohms/1000 ft (1000 m)	
Inner	1.45 (1.48)
Outer	0.58 (1.90)
dc Breakdown, volts	4000
Jacket Spark, volts RMS	8000
Capacitance, pF/ft (m)	23.1 (75.8)
Inductance, μH/ft (m)	0.058 (0.19)
Mechanical	
Outer Conductor	Copper
Inner Conductor	Copper-Clad Aluminum
Diameter over Jacket, in (mm)	0.63 (16)
Diameter over Copper Outer Conductor, in (mm)	0.55 (14)
Diameter Inner Conductor, in (mm)	0.189 (4.6)
Nominal Inside Transverse Dimensions, cm	1.11
Minimum Bending Radius, in (mm)	5 (125)
Number of Bends, minimum (typical)	15 (50)
Bending Moment, lb-ft (N·m)	2.8 (3.8)
Cable Weight, lb/ft (kg/m)	0.15 (0.22)
Tensile Strength, lb (kg)	250 (113)
Flat Plate Crush Strength, lb/in (kg/mm)	110 (2.0)

Attenuation and Average Power Ratings

Frequency MHz	Attenuation dB/100 ft	Attenuation dB/100 m	Average Power, kW
0.5	0.045	0.149	40.0
1	0.064	0.211	35.8
1.5	0.079	0.259	29.2
2	0.091	0.299	25.3
10	0.205	0.672	11.3
20	0.291	0.954	7.93
30	0.357	1.17	6.46
50	0.463	1.52	4.98
88	0.619	2.03	3.73
100	0.661	2.17	3.49
108	0.688	2.26	3.36
150	0.815	2.67	2.83
174	0.880	2.89	2.62
200	0.946	3.10	2.44
300	1.17	3.83	1.97
400	1.36	4.46	1.70
450	1.45	4.75	1.59
500	1.53	5.02	1.51
512	1.55	5.08	1.49
600	1.69	5.53	1.37
700	1.83	6.01	1.26
800	1.97	6.46	1.17
824	2.00	6.56	1.15
894	2.09	6.85	1.10
960	2.17	7.12	1.06
1000	2.22	7.28	1.04
1250	2.51	8.23	0.921
1500	2.77	9.09	0.833
1700	2.97	9.74	0.777
1800	3.07	10.1	0.753
2000	3.25	10.7	0.710
2100	3.34	11.0	0.691
2200	3.43	11.2	0.673
2300	3.52	11.5	0.657
3000	4.09	13.4	0.565
3400	4.39	14.4	0.526
4000	4.82	15.8	0.479
5000	5.49	18.0	0.421
6000	6.11	20.1	0.378
8000	7.26	23.8	0.318
8800	7.69	25.2	0.300

Standard Conditions:

For attenuation, VSWR 1.0, ambient temperature 20°C (68°F).

For Average Power, VSWR 1.0, ambient temperature 40°C (104°F), inner conductor temperature 100°C (212°F), no solar loading.

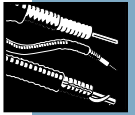

N Male
L4PNM-RC



N Female
L4PNF-RC



7-16 DIN Male
L4PDM-RC



7-16 DIN Female
L4PDF-RC



7/8" EIA Flange
L44R



UHF Male
L44P

Connectors

Interface	Description	Type Number	Inner Contact Attachment	Outer Contact Attachment	Plating Code	Max. Length in (mm)	Max. Dia. in (mm)
N Male	Hex Head	L4PNM-H	Solder	Self-Flare	SG	2.6 (66)	0.95 (24.1)
N Male	RingFlare	L4PNM-RC	Captivated	RingFlare	SG	3.0 (75.7)	0.86 (21.8)
N Male	Right Angle, Hex	L4PNR-H	Solder	Self-Flare	SG	3.2/1.5 (81/38)	0.95 (24.1)
N Male	Right Angle, Hex	L4PNR-HC	Captivated	Self-Flare	SG	3.2/1.5 (81/38)	0.91 (23.1)
N Female	-	L4PNF	Solder	Self-Flare	SG	2.6 (66)	0.94 (23.9)
N Female	Bulk Head	L4PNF-BH	Solder	Self-Flare	SG	2.6 (66)	0.96 (24.4)
N Female	Panel Mount	L4PNF-PM	Solder	Self-Flare	SG	2.6 (66)	1.0 (25.4)
N Female	RingFlare	L4PNF-RC	Captivated	RingFlare	SG	2.8 (71)	0.86 (21.8)
7-16 DIN Male	-	L4PDM	Solder	Self-Flare	SS	2.6 (66)	1.4 (35.6)
7-16 DIN Male	Right Angle	L4PDR	Solder	Self-Flare	SS	1.8/2.8 (46/72)	1.41 (35.9)
7-16 DIN Male	Right Angle	L4PDR-C	Captivated	Self-Flare	SS	1.8/2.8 (46/72)	1.41 (35.9)
7-16 DIN Male	RingFlare	L4PDM-RC	Captivated	Ring-Flare	SS	2.64 (67.1)	0.86 (21.8)
7-16 DIN Female	-	L4PDF	Solder	Self-Flare	SS	2.7 (69)	1.1 (27.9)
7-16 DIN Female	Bulk Head	L4PDF-BH	Solder	Self-Flare	SS	2.73 (69.4)	1.62 (41.1)
7-16 DIN Female	Bulk Head	L4PDF-BHC	Captivated	Self-Flare	SS	2.9 (74)	1.63 (41.4)
7-16 DIN Female	Panel Mount	L4PDF-PM	Solder	Self-Flare	SS	2.7 (69)	1.2 (29.4)
7-16 DIN Female	RingFlare	L4PDF-RC	Captivated	RingFlare	SS	2.8 (71)	0.86 (21.8)
7/8" EIA Flange	-	L44R	Solder	Self-Flare	BB	3.2 (81)	2.25 (57.2)
7/8" EIA Flange	Right Angle	124990-1	Solder	Self-Flare	BB	2.3/1.6 (58/41)	2.25 (57.2)
F Flange Male	-	L44F	Solder	Self-Flare	BB	2.3 (58)	2.25 (57.2)
F Flange Female	-	209865	Solder	Self-Flare	BS	2.3 (58)	2.25 (57.2)
UHF Male	-	L44P	Solder	Self-Flare	BB	2.3 (58)	0.91 (23.1)
UHF Female	-	L44U	Solder	Self-Flare	BS	2.3 (58)	0.91 (23.1)
HN Male	-	L44J	Solder	Self-Flare	BB	2.5 (64)	0.91 (23.1)
LC Male	-	L44M	Solder	Self-Flare	BB	3.6 (91)	0.91 (23.1)
TNC Female	-	L44NT	Solder	Self-Flare	BB	2.8 (71)	0.94 (23.9)
End Terminal	-	L44T	Solder	Self-Flare	BB	4.0 (102)	0.91 (23.1)
Splice	-	L44Z	Solder	Self-Flare	BB	3.2 (81)	1.1 (27.9)

Plating Codes: BB - Brass Body and Pin, BS - Brass Body and Silver Plated Pin, SG - Silver Plated Body and Gold Plated Pin, SS - Silver Plated Body and Pin

Connector Accessories – See page 624

Factory Attached Connectors – For factory made cable assemblies and jumper cables, see pages 584-587.



Standard VSWR Specifications

Frequency Band, GHz	Type No.	Assembly VSWR, Maximum (R.L., dB)				
		1-25 ft (0.3-8 m)	25-100 ft (8-30 m)	100-200 ft (30-60 m)	200-500 ft (60-150 m)	Above 500 ft (150 m)
0.806-0.960 and 1.7-2.0	LDF4-50A	1.09 (27.3)*	1.11 (25.7)*	1.13 (24.3)*	1.13 (24.3)*	1.13 (24.3)**
	LDF4RN-50A	1.09 (27.3)*	1.11 (25.7)*	1.13 (24.3)*	1.13 (24.3)*	1.13 (24.3)**

* Expected typical values based on guaranteed 1.13 VSWR for bulk cable and Type N or DIN straight connectors. If guaranteed values are required, contact Andrew.

** 1.13 VSWR guaranteed for bulk standard cable lengths 500 ft and above.

Low VSWR Specifications, Type LDF4P-50A-()

Frequency Band, GHz	Type No.	Using Connector Type**	Assembly VSWR, Maximum (R.L., dB)				
			1-25 ft (0.3-8 m)	25-100 ft (8-30 m)	100-200 ft (30-60 m)	200-500 ft (60-150 m)	Above 500 ft (150 m)
0.806-0.960	LDF4P-50A-40	N	1.10 (26.4)	1.10 (26.4)	1.10 (26.4)	1.10 (26.4)	1.10 (26.4)
		7-16 DIN	1.10 (26.4)	1.10 (26.4)	1.10 (26.4)	1.10 (26.4)	1.10 (26.4)
0.806-0.960 and 1.7-2.3	LDF4P-50A-42	N	1.10 (26.4)	1.10 (26.4)	1.10 (26.4)	1.10 (26.4)	1.10 (26.4)
		7-16 DIN	1.10 (26.4)	1.10 (26.4)	1.10 (26.4)	1.10 (26.4)	1.10 (26.4)
1.427-1.535	LDF4P-50A-4	N	1.10 (26.4)	1.10 (26.4)	1.12 (24.9)	1.15 (23.1)	1.15 (23.1)
		F Flange, 7/8" EIA	1.10 (26.4)	1.10 (26.4)	1.12 (24.9)	1.15 (23.1)	1.15 (23.1)
		7-16 DIN	1.10 (26.4)	1.10 (26.4)	1.12 (24.9)	1.15 (23.1)	1.15 (23.1)
		SC Male, TNC Female	1.20 (20.8)	1.20 (20.8)	1.20 (20.8)	1.20 (20.8)	1.20 (20.8)
		LC Male	1.35 (16.5)	1.35 (16.5)	1.32 (17.2)	1.30 (17.7)	1.30 (17.7)
		Right Angle N Male	1.35 (16.5)	1.35 (16.5)	1.32 (17.2)	1.30 (17.7)	1.30 (17.7)
1.6-2.3	LDF4P-50A-10	N	1.12 (24.9)	1.15 (23.1)	1.15 (23.1)	1.15 (23.1)	1.15 (23.1)
		F Flange	1.12 (24.9)	1.15 (23.1)	1.15 (23.1)	1.15 (23.1)	1.15 (23.1)
		7-16 DIN	1.12 (24.9)	1.15 (23.1)	1.15 (23.1)	1.15 (23.1)	1.15 (23.1)
		F Flange Female	1.20 (20.8)	1.20 (20.8)	1.20 (20.8)	1.20 (20.8)	1.20 (20.8)
		SC Male	1.20 (20.8)	1.20 (20.8)	1.20 (20.8)	1.20 (20.8)	1.20 (20.8)
		Right Angle N Male	1.35 (16.5)	1.35 (16.5)	1.30 (17.7)	1.30 (17.7)	1.30 (17.7)
		TNC Female	1.35 (16.5)	1.35 (16.5)	1.30 (17.7)	1.30 (17.7)	1.30 (17.7)
		LC Male	1.35 (16.5)	1.35 (16.5)	1.30 (17.7)	1.30 (17.7)	1.30 (17.7)
1.7-2.3	LDF4P-50A-41	N	1.10 (26.4)	1.10 (26.4)	1.10 (26.4)	1.10 (26.4)	1.10 (26.4)
		7-16 DIN	1.10 (26.4)	1.10 (26.4)	1.10 (26.4)	1.10 (26.4)	1.10 (26.4)
0.940-2.7	LDF4P-50A-3	N	1.12 (24.9)	1.15 (23.1)	1.18 (21.6)	1.20 (20.8)	1.20 (20.8)
		F Flange, 7/8" EIA	1.12 (24.9)	1.15 (23.1)	1.18 (21.6)	1.20 (20.8)	1.20 (20.8)
		7-16 DIN Male	1.12 (24.9)	1.15 (23.1)	1.18 (21.6)	1.20 (20.8)	1.20 (20.8)
		7-16 DIN Female	1.20 (20.8)	1.20 (20.8)	1.22 (20.1)	1.22 (20.1)	1.22 (20.1)
		SC Male	1.20 (20.8)	1.20 (20.8)	1.22 (20.1)	1.22 (20.1)	1.22 (20.1)
		LC Male	1.40 (15.6)	1.40 (15.6)	1.35 (16.5)	1.35 (16.5)	1.30 (17.7)
		Right Angle N Male	1.40 (15.6)	1.40 (15.6)	1.35 (16.5)	1.35 (16.5)	1.30 (17.7)
		TNC Female	1.40 (15.6)	1.40 (15.6)	1.35 (16.5)	1.35 (16.5)	1.30 (17.7)
0.01-0.806	LDF4P-50A-6	N Male	1.06 (30.7)	1.10 (26.4)	1.15 (23.1)	1.20 (20.8)	1.25 (19.1)
		7/8" EIA	1.06 (30.7)	1.10 (26.4)	1.15 (23.1)	1.20 (20.8)	1.25 (19.1)
		7-16 DIN	1.06 (30.7)	1.10 (26.4)	1.15 (23.1)	1.20 (20.8)	1.25 (19.1)
		SC Male	1.06 (30.7)	1.10 (26.4)	1.15 (23.1)	1.20 (20.8)	1.25 (19.1)
		LC Male, TNC Female	1.20 (20.8)	1.20 (20.8)	1.25 (19.1)	1.30 (17.7)	1.30 (17.7)
		Right Angle N Male	1.25 (19.1)	1.25 (19.1)	1.28 (18.2)	1.30 (17.7)	1.32 (17.2)
0.01-2.7*	LDF4P-50A-7	N Male	1.12 (24.9)	1.15 (23.1)	1.18 (21.6)	1.20 (20.8)	1.25 (19.1)
		N Female	1.20 (20.8)	1.20 (20.8)	1.20 (20.8)	1.20 (20.8)	1.25 (19.1)
		7/8" EIA	1.12 (24.9)	1.15 (23.1)	1.18 (21.6)	1.20 (20.8)	1.25 (19.1)
		7-16 DIN	1.20 (20.8)	1.20 (20.8)	1.20 (20.8)	1.20 (20.8)	1.25 (19.1)
		SC Male	1.20 (20.8)	1.20 (20.8)	1.20 (20.8)	1.25 (19.1)	1.25 (19.1)
		Right Angle N Male	1.30 (17.7)	1.30 (17.7)	1.30 (17.7)	1.30 (17.7)	1.30 (17.7)
		TNC Female	1.30 (17.7)	1.30 (17.7)	1.30 (17.7)	1.30 (17.7)	1.30 (17.7)
		LC Male	1.35 (16.5)	1.32 (17.2)	1.32 (17.2)	1.32 (17.2)	1.32 (17.2)
3.6-6.5*	LDF4P-50A-5	N Male	1.25 (19.1)	1.25 (19.1)	1.25 (19.1)	1.25 (19.1)	1.25 (19.1)
		7/8" EIA	1.25 (19.1)	1.25 (19.1)	1.25 (19.1)	1.25 (19.1)	1.25 (19.1)
		SC Male	1.30 (17.7)	1.30 (17.7)	1.30 (17.7)	1.30 (17.7)	1.30 (17.7)
0.1-4.2*	LDF4P-50A-8	N Male	1.15 (23.1)	1.15 (23.1)	1.20 (20.8)	1.20 (20.8)	1.25 (19.1)
		7-16 DIN Male	1.15 (23.1)	1.15 (23.1)	1.20 (20.8)	1.20 (20.8)	1.25 (19.1)
		SC Male	1.30 (17.7)	1.30 (17.7)	1.30 (17.7)	1.30 (17.7)	1.30 (17.7)
		TNC Female	1.30 (17.7)	1.30 (17.7)	1.30 (17.7)	1.30 (17.7)	1.30 (17.7)
0.1-8.4*	LDF4P-50A-9	N Male	1.30 (17.7)	1.30 (17.7)	1.30 (17.7)	1.30 (17.7)	1.30 (17.7)
		N Female	1.40 (15.6)	1.35 (16.5)	1.35 (16.5)	1.35 (16.5)	1.35 (16.5)

* Specify operating band. ** Connectors ordered separately.

VSWR values apply to straight connectors only (except when noted otherwise), are guaranteed for factory fit assemblies, and are typical for field cut lengths. If two different connector interfaces are selected, the higher VSWR value is guaranteed.

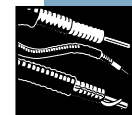

Accessories

Description	Type No.
Hangers – For more hangers, adapters and mounting hardware see pages 599-607	
Standard Hangers Kit of 10. Recommended maximum spacing is 3-ft (1 m). For different spacing recommendations, refer to Cable Hanger Spacing, page 593-598	43211A
Hardware Kit of 10. 3/8" bolts, lockwashers, nuts	
3/4" (19mm) long	31769-5
1" (25mm) long	31769-1
Snap-In Hangers Kit of 10. For prepunched 3/4" (19mm) holes on tower member or adapters, Recommended maximum spacing is 3-ft. For different spacing recommendations, refer to Cable Hanger Spacing, page 593-598	206706-1
Click-On Hangers Kit of 10. Recommended maximum spacing is 3-ft Mounting Hardware see page 605	L4CLICK
Kwik-Clamps Kit of 10. See page 607 for hanger options	
Support/Hoisting Grip. Use at 200-ft (60m) intervals.	
Grip with one clamp	L4SGRIP
Support clamp kit of 10	L4SGRIP-4IK
Standard Hoisting Grip	43094

Description	Type No.	
Grounding and Surge Protection – for additional grounding kits and our surge protection offerings, see pages 609-616		
SureGround Grounding Kit with standard weatherproofing		
Factory attached one-hole lug, 600 mm (24") lead	SGL4-06B1	
Factory attached two-hole lug, 600 mm (24") lead	SGL4-06B2	
Field attached two-hole lug, 1500 mm (59") lead	SGL4-15B4	
SureGround Plus Grounding Kit with weatherproofing boot		
Factory attached one-hole lug, 600 mm (24") lead	SGPL4-06B1	
Factory attached two-hole lug, 600 mm (24") lead	SGPL4-06B2	
Field attached two-hole lug, 1500 mm (59") lead	SGPL4-15B4	
Weatherproofing – for additional weatherproofing information see pages 617-618		
WeatherShield™ Connector Protection Housing		
LDF5 to LDF4	WS-L5L4	
LDF6 to LDF4	WS-L6L4	
LDF7 to LDF4	WS-L7L4	
Cold Shrink Weatherproofing Kit		
1/2" Coax N Connector to 1/2" Coax N Connector	241474-4	
5/8" Coax to 1/2" Coax	242475-13	
7/8" Coax to 1/2" Coax	241475-9	
1-1/4" or 1-5/8" Coax to 1/2" Coax	241475-5A	
2 1/4" Coax to 1/2" Coax	241475-8	
1/2" to 1-1/2" Omni/Panel base Type N or DIN	241548-8	
1/2" to 2" Omni/Panel base Type N or DIN	241548-9	
1/2" LDF4 to Antenna Type N interface	241548-4	
Connector/Splice Weatherproofing Kit	221213	
Entry Systems – For entry systems offerings see pages 619-620		
Standard Cable Entry Boots	4" Boots	5" Boots
One Hole:	204679A-5	48939A-6
Three Hole:	204679A-7	48939A-8
Four Hole	204679A-16	48939A-17
Tools – for additional tool offerings see pages 620-623		
EASIAX® Plus Automated Cable Prep Tool	CPT-L4ARC	
EASIAX® Cutting Tool	207866	
Cable Flare Tool	224363	
DIN Connector Coupling Torque Wrench	244377	
N Connector Coupling Torque Wrench	244379	



5/8" Foam Dielectric, LDF Series – 50-ohm

LDF4.5-50

Description	Type No.
-------------	----------

Cable Ordering Information

Standard Cable	
5/8" Standard Cable, Standard Jacket	LDF4.5-50
Fire Retardant Cables	
5/8" Fire Retardant Jacket (CATVX)	LDF4.5RN-50
5/8" Fire Retardant Jacket (CATVR)	LDF4.5RN-50
Low VSWR and Specialized Cables	
5/8" Low VSWR, specify operating band	LDF4.5P-50-(**)

** Insert suffix number from "Low VSWR Specifications" table, page 501.

Characteristics

Electrical	
Impedance, ohms	50 ± 1
Maximum Frequency, GHz	6.1
Velocity, percent	89
Peak Power Rating, kW	62
dc resistance, ohms/1000 ft (1000 m)	
Inner	0.15 (0.49)
Outer	0.42 (1.37)
dc Breakdown, volts	5000
Jacket Spark, volts RMS	8000
Capacitance, pF/ft (m)	23.2 (76.1)
Inductance, µH/ft (m)	0.057 (0.187)
Mechanical	
Outer Conductor	Copper
Inner Conductor	Copper-Clad Aluminum
Diameter over Jacket, in (mm)	0.865 (21.97)
Diameter over Copper Outer Conductor, in (mm)	0.777 (19.74)
Diameter Inner Conductor, in (mm)	0.277 (7.04)
Minimum Bending Radius, in (mm)	8 (200)
Number of Bends, minimum (typical)	15 (40)
Bending Moment, lb-ft (N·m)	2.8 (3.8)
Cable Weight, lb/ft (kg/m)	0.15 (0.22)
Tensile Strength, lb (kg)	800 (363)
Flat Plate Crush Strength, lb/in (kg/mm)	70 (1.3)

Attenuation and Average Power

Frequency MHz	Attenuation dB/100 ft	Attenuation dB/100 m	Average Power, kW
0.5	0.032	0.105	62.0
1	0.045	0.149	53.5
1.5	0.056	0.183	43.6
2	0.064	0.211	37.7
10	0.145	0.476	16.7
20	0.207	0.678	11.8
30	0.254	0.834	9.57
50	0.330	1.08	7.36
88	0.443	1.45	5.49
100	0.473	1.55	5.14
108	0.493	1.62	4.93
150	0.586	1.92	4.15
174	0.633	2.08	3.84
200	0.682	2.24	3.57
300	0.847	2.78	2.87
400	0.989	3.24	2.46
450	1.05	3.46	2.31
500	1.12	3.66	2.18
512	1.13	3.71	2.15
600	1.23	4.05	1.97
700	1.34	4.41	1.81
800	1.45	4.75	1.68
824	1.47	4.83	1.65
894	1.54	5.05	1.58
960	1.60	5.26	1.52
1000	1.64	5.38	1.48
1250	1.86	6.11	1.31
1500	2.07	6.78	1.18
1700	2.22	7.29	1.10
1800	2.30	7.54	1.06
2000	2.44	8.02	0.996
2100	2.51	8.25	0.968
2200	2.58	8.48	0.942
2300	2.65	8.70	0.918
3000	3.11	10.2	0.783
3400	3.35	11.0	0.726
4000	3.70	12.1	0.658
5000	4.25	13.9	0.573
6000	4.76	15.6	0.511
6100	4.81	15.8	0.506

Standard Conditions:

For Attenuation. VSWR 1.0, ambient temperature 20°C (68°F).

For Average Power. VSWR 1.0, ambient temperature 40°C (104°F), inner conductor temperature 100°C (212°F); no solar loading.



N Male
L4.5PNM-RC



N Female
L4.5PNF-RC



7-16 DIN Male
L4.5PDM-RC



7-16 DIN Female
L4.5PDF-RC

Connectors

Interface	Description	Type Number	Inner Contact Attachment	Outer Contact Attachment	Plating Code	Max. Length in (mm)	Max. Dia. in (mm)
N Male	Ring Flare	L4.5PNM-RC	Captivated	Self Flare	SG	3.2 (81.5)	1.42 (36)
N Female	Ring Flare	L4.5PNF-RC	Captivated	Self Flare	SG	3.0 (76)	1.32 (33.5)
7-16 DIN Male	Ring Flare	L4.5PDM-RC	Captivated	Self Flare	SS	3.1 (78)	1.17 (29.8)
7-16 DIN Female	Ring Flare	L4.5PDF-RC	Captivated	Self Flare	SS	3.25 (82)	1.17 (29.8)

Plating Codes: SG - Silver Plated Body and Gold Plated Pin, SS - Silver Plated Body and Pin

Connector Accessories – See page 624.

Factory Attached Connectors – For factory made cable assemblies and jumper cables, see pages 584-587.

Standard VSWR Specifications

Frequency Band, GHz	Type Number	Assembly VSWR, Maximum (R.L., dB)				
		1-25 ft (0.3-8 m)	25-100 ft (8-30 m)	100-200 ft (30-60 m)	200-500 ft (60-150 m)	Above 500 ft (150 m)
0.806-0.960	LDF4.5-50	1.12 (24.9)*	1.13 (24.3)*	1.13 (24.3)*	1.13 (24.3)*	1.13 (24.3)**
and 1.7-2.0	LDF4.5RN-50	1.12 (24.9)*	1.13 (24.3)*	1.13 (24.3)*	1.13 (24.3)*	1.13 (24.3)**

* Expected typical values based on guaranteed 1.13 VSWR for bulk cable and Type N or DIN straight connectors. If guaranteed values are required, contact Andrew.

** 1.13 VSWR guaranteed for bulk standard cable lengths 500 ft and above.

Low VSWR Specifications, Type LDF4.5P-50-()

Frequency Band, GHz	Type Number	Using Connector Type*	Assembly VSWR, Maximum (R.L., dB)				
			1-25 ft (0.3-8 m)	25-100 ft (8-30 m)	100-200 ft (30-60 m)	200-500 ft (60-150 m)	Above 500 ft (150 m)
0.806-0.960	LDF4.5P-50-40	N	1.08 (28.3)	1.08 (28.3)	1.09 (27.3)	1.10 (26.4)	1.10 (26.4)
		7-16 DIN	1.08 (28.3)	1.08 (28.3)	1.09 (27.3)	1.10 (26.4)	1.10 (26.4)
1.7-2.3	LDF4.5P-50-41	7-16 DIN	1.10 (26.4)	1.10 (26.4)	1.10 (26.4)	1.10 (26.4)	1.10 (26.4)
0.806-0.960 and 1.7-2.3	LDF4.5P-50-42	7-16 DIN	1.10 (26.4)	1.10 (26.4)	1.10 (26.4)	1.10 (26.4)	1.10 (26.4)

* Connectors ordered separately

VSWR values apply to straight connectors only, are guaranteed for factory fit assemblies, and are typical for field cut lengths. If two different connector interfaces are selected, the higher VSWR value is guaranteed.



Accessories

Description	Type No.
Hangers – For more hangers, adapters and mounting hardware see pages 599-607	
Standard Hangers Kit of 10. Recommended maximum spacing is 3-ft (1 m). For different spacing recommendations, refer to Cable Hanger Spacing, page 593-598	42396A-9
Hardware Kit of 10. 3/8" bolts, lockwashers, nuts	
3/4" (19mm) long	31769-5
1" (25mm) long	31769-1
Snap-In Hangers Kit of 10. For prepunched 3/4" (19mm) holes on tower member or adapters, Recommended maximum spacing is 3-ft. For different spacing recommendations, refer to Cable Hanger Spacing, page 593-598	206706A-6
Click-On Hangers Kit of 10. Recommended maximum spacing is 3-ft	L45CLICK
Mounting Hardware see page 605	
Kwik-Clamps Kit of 10. See page 607 for hanger options	
Support/Hoisting Grip. Use at 200-ft (60m) intervals.	
Grip with one clamp	L45SGRIP
Support clamp kit of 10	L45SGRIP-4IK
Standard Hoisting Grip	29958

Description	Type No.
Grounding and Surge Protection – for additional grounding kits and our surge protection offerings, see pages 609-616	
SureGround Grounding Kit with standard weatherproofing	
Factory attached one-hole lug, 600 mm (24") lead	SGL45-06B1
Factory attached two-hole lug, 600 mm (24") lead	SGL45-06B2
Field attached two-hole lug, 1500 mm (59") lead	SGL45-15B4
SureGround Plus Grounding Kit with weatherproofing boot	
Factory attached one-hole lug, 600 mm (24") lead	SGPL45-06B1
Factory attached two-hole lug, 600 mm (24") lead	SGPL45-06B2
Field attached one-hole lug, 600 mm (24") lead	SGPL45-06B3
Field attached two-hole lug, 1500 mm (59") lead	SGPL45-15B4
Weatherproofing – for additional weatherproofing information see pages 617-618	
Cold Shrink Weatherproofing Kit	
5/8" Coax to 1/4", 3/8" or 1/2" Coax	241475-13
5/8" Coax to 5/8" Coax	241474-7
5/8" Coax to Antenna Type N or DIN interface	241548-7
Connector/Splice Weatherproofing Kit	221213
Entry Systems – For entry systems offerings see pages 619-620	
Standard Cable Entry Boots	4" Boots 5" Boots
One Hole:	204679A-13 48939A-14
Three Hole:	204679A-14 48939A-15
Tools – for additional tool offerings see pages 620-623	
EASIAx® Plus Automated Cable Prep Tool	CPT-L45
5/8" Connector Torque Wrench	244376
DIN Connector Coupling Torque Wrench	244377
N Connector Coupling Torque Wrench	244379

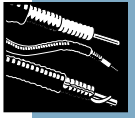

7/8" Flexible Feeder, Foam Dielectric VXL Series – 50-ohm



HELIAX® Coaxial Cables

VXL5-50

Description	Type No.
Cable Ordering Information	
Standard Cable	
7/8" Standard Cable, Standard Jacket	VXL5-50
Fire Retardant Cable	
7/8" Fire Retardant Jacket (CATVR)	VXL5RN-50
Low VSWR Cables	
7/8" Low VSWR, specify operating band	VXL5P-50-(**)
Jumper Cable Assemblies - See page 584	
**Insert suffix number from "Low VSWR Specifications" table, page 504	
Characteristics	
Electrical	
Impedance, ohms	50 ± 1
Maximum Frequency, GHz	4.9
Velocity, percent	88
Peak Power Rating, kW	90
dc Resistance, ohms/1000 ft (1000 m)	
Inner	0.82 (2.70)
Outer	0.36 (1.19)
dc Breakdown, volts	6000
Jacket Spark, volts RMS	8000
Capacitance, pF/ft (m)	22.6 (74.2)
Inductance, µH/ft (m)	0.06 (0.197)
Mechanical	
Outer Conductor	Copper
Inner Conductor	Copper Tube
Diameter over Jacket, in (mm)	1.08 (27.5)
Diameter over Copper Outer Conductor, in (mm)	0.98 (24.9)
Diameter Inner Conductor, in (mm)	0.371 (9.42)
Minimum Bending Radius, in (mm)	5 (125)
Number of Bends, minimum (typical)	15 (40)
Bending Moment, lb-ft (N·m)	12 (16.3)
Cable Weight, lb/ft (kg/m)	0.29 (0.43)
Tensile Strength, lb (kg)	225 (102)
Flat Plate Crush Strength, lb/in (kg/mm)	80 (1.4)

Attenuation and Average Power

Frequency MHz	Attenuation dB/100 ft	Attenuation dB/100 m	Average Power, kW
0.5	0.027	0.089	90.0
1	0.038	0.126	68.5
1.5	0.047	0.154	55.9
2	0.054	0.178	48.4
10	0.122	0.402	21.5
20	0.174	0.571	15.1
30	0.214	0.702	12.3
50	0.278	0.911	9.47
88	0.372	1.22	7.07
100	0.397	1.30	6.62
108	0.413	1.36	6.36
150	0.491	1.61	5.36
174	0.530	1.74	4.96
200	0.571	1.87	4.61
300	0.707	2.32	3.72
400	0.825	2.71	3.19
450	0.878	2.88	2.99
500	0.930	3.05	2.83
512	0.942	3.09	2.79
600	1.03	3.37	2.56
700	1.12	3.66	2.36
800	1.20	3.94	2.19
824	1.22	4.01	2.16
894	1.28	4.19	2.06
960	1.33	4.36	1.98
1000	1.36	4.46	1.94
1250	1.54	5.05	1.71
1500	1.71	5.60	1.54
1700	1.83	6.01	1.44
1800	1.89	6.21	1.39
2000	2.01	6.59	1.31
2100	2.07	6.78	1.27
2200	2.12	6.97	1.24
2300	2.18	7.15	1.21
3000	2.54	8.35	1.04
3400	2.74	8.99	0.961
4000	3.02	9.90	0.873
4900	3.41	11.2	0.772

Standard Conditions:

For Attenuation, VSWR 1.0 ambient temperature 20°C (68°F).

For Average Power, VSWR 1.0, ambient temperature 40°C (104°F), inner conductor temperature 100°C (212°F), no solar loading.



N Male
V5PNM-RPC



N Female
V5PNF-RPC



7-16 DIN Male
V5PDM-RPC



7-16 DIN Female
V5PDF-RPC

Connectors

Interface	Type Number	Inner Contact Attachment	Outer Contact Attachment	Plating Code	Max. Length in (mm)	Max. Dia. in (mm)
N Male One-Piece	V5PNM-RPC	Captivated	Self-Flare	SG	2.9 (74)	1.46 (37.2)
N Female One-Piece	V5PNF-RPC	Captivated	Self-Flare	SG	2.7 (69)	1.46 (37.2)
7-16 DIN Male One-Piece	V5PDM-RPC	Captivated	Self-Flare	SS	2.7 (69)	1.46 (37.2)
7-16 DIN Female One-Piece	V5PDF-RPC	Captivated	Self-Flare	SS	2.33 (59)	1.46 (37.2)
7/8" EIA Flange	V5E78	Captivated	Self-Flare	SG	3.38 (86)	2.27 (56.7)

Plating Codes: SG - Silver Plated Body and Gold Plated Pin, SS - Silver Plated Body and Pin

Connector Accessories – See page 624

Factory Attached Connectors – For factory made cable assemblies and jumper cables, see pages 584-587.

Standard VSWR Specifications

Frequency Band, GHz	Type Number	Assembly VSWR, Maximum (R.L., dB)				
		1-25 ft (0.3-8 m)	25-100 ft (8-30 m)	100-200 ft (30-60 m)	200-500 ft (60-150 m)	Above 500 ft (150 m)
0.806-0.960 and 1.7-2.0	VXL5-50	1.09 (27.3)*	1.10 (26.4)*	1.12 (24.9)*	1.13 (24.3)*	1.13 (24.3)**
	VXL5RN-50	1.09 (27.3)*	1.10 (26.4)*	1.12 (24.9)*	1.13 (24.3)*	1.13 (24.3)**

* Expected typical values based on guaranteed 1.13 VSWR for bulk cable and Type N or DIN straight connectors. If guaranteed values are required, contact Andrew.

** 1.13 VSWR guaranteed for bulk standard cable lengths 500 ft and above.

Low VSWR Specifications, Type VXL5P-50-()

Frequency Band, GHz	Type Number	Using Connector Type*	Assembly VSWR, Maximum (R.L., dB)				
			1-25 ft (0.3-8 m)	25-100 ft (8-30 m)	100-200 ft (30-60 m)	200-500 ft (60-150 m)	Above 500 ft (150 m)
0.806-0.960	VXL5P-50-40	N	1.08 (28.3)	1.08 (28.3)	1.09 (27.3)	1.10 (26.4)	1.10 (26.4)
		7-16 DIN	1.08 (28.3)	1.08 (28.3)	1.09 (27.3)	1.10 (26.4)	1.10 (26.4)
0.806-0.960 and 1.7-2.3	VXL5P-50-42	N	1.10 (26.4)	1.10 (26.4)	1.10 (26.4)	1.10 (26.4)	1.10 (26.4)
		7-16 DIN	1.10 (26.4)	1.10 (26.4)	1.10 (26.4)	1.10 (26.4)	1.10 (26.4)
1.7-2.3	VXL5P-50-41	N	1.10 (26.4)	1.10 (26.4)	1.10 (26.4)	1.10 (26.4)	1.10 (26.4)
		7-16 DIN	1.10 (26.4)	1.10 (26.4)	1.10 (26.4)	1.10 (26.4)	1.10 (26.4)

* Connectors ordered separately

VSWR values apply to straight connectors only, are guaranteed for factory fit assemblies, and are typical for field cut lengths. If two different connector interfaces are selected, the higher VSWR value is guaranteed.



Accessories

Description	Type No.
Hangers – For more hangers, adapters and mounting hardware see pages 599-607	
Standard Hangers Kit of 10. Recommended maximum spacing is 3-ft (1 m). For different spacing recommendations, refer to Cable Hanger Spacing, page 593-598	42396A-5
Hardware Kit of 10. 3/8" bolts, lockwashers, nuts	
3/4" (19mm) long	31769-5
1" (25mm) long	31769-1
Snap-in Hangers Kit of 10. For prepunched 3/4" (19mm) holes on tower member or adapters, Recommended maximum spacing is 3-ft. For different spacing recommendations, refer to Cable Hanger Spacing, page 593-598	206706A-2
Click-On Hangers Kit of 10. Recommended maximum spacing is 3-ft	L5CLICK
Mounting Hardware see page 605	
Kwik-Clamps Kit of 10. See page 607 for hanger options	
Support/Hoisting Grip. Use at 200-ft (60m) intervals.	
Grip with one clamp	L5GRIP
Support clamp kit of 10	L5GRIP-5IK
Standard Hoisting Grip	19256B

Description	Type No.	
Grounding and Surge Protection – for additional grounding kits and our surge protection offerings, see pages 609-616		
SureGround Grounding Kit with standard weatherproofing		
Factory attached one-hole lug, 600 mm (24") lead	SGL5-06B1	
Factory attached two-hole lug, 600 mm (24") lead	SGL5-06B2	
Field attached two-hole lug, 1500 mm (59") lead	SGL5-15B4	
SureGround Plus Grounding Kit with weatherproofing boot		
Factory attached one-hole lug, 600 mm (24") lead	SGPL5-06B1	
Factory attached two-hole lug, 600 mm (24") lead	SGPL5-06B2	
Field attached two-hole lug, 1500 mm (59") lead	SGPL5-15B4	
Weatherproofing – for additional weatherproofing information see pages 617-618		
WeatherShield™ Connector Protection Housing		
VXL5 to LDF4	WS-L5L4	
VXL5 to FSJ4	WS-L5F4	
Cold Shrink Weatherproofing Kit		
7/8" Coax to 7/8" Coax N Connectors	241474-5	
1-5/8" Coax to 7/8" Coax N Connectors	241475-3	
7/8" Coax to 1/4" Coax	241475-12	
7/8" Coax to 3/8" or 1/2" Coax	241475-9	
7/8" Coax to Antenna Type N or DIN interface	241548-5	
7/8" to APTL5 Arrestors	241474-5	
Connector/Splice Weatherproofing Kit	221213	
Entry Systems – For entry systems offerings see pages 619-620		
Standard Cable Entry Boots	4" Boots	5" Boots
One Hole:	204679A-2	48939A-1
Two Hole:	204679A-18	–
Three Hole:	204679A-15	48939A-2
Tools – for additional tool offerings see pages 620-623		
EASIAx® Plus Automated Cable Prep Tool	CPTL5A	
EASIAx® Cutting Tool	222951	
Cable Flaring Tool	224368	
7/8" Connector Torque Wrench	244378	
DIN Connector Coupling Torque Wrench	244377	
N Connector Coupling Torque Wrench	244379	



7/8" Foam Dielectric, LDF Series – 50-ohm



LDF5-50A

Description	Type No.
Cable Ordering Information	
Standard Cable	
7/8" Standard Cable, Standard Jacket	LDF5-50A
Fire Retardant Cable	
7/8" Fire Retardant Jacket (CATVR)	LDF5RN-50A
Low VSWR and Specialized Cables	
7/8" Low VSWR, specify operating band	LDF5P-50A-(**)

** Insert suffix number from "Low VSWR Specifications" table, page 508.

Characteristics

Electrical	
Impedance, ohms	50 ± 1
Maximum Frequency, GHz	5.0
Velocity, percent	89
Peak Power Rating, kW	91
dc Resistance, ohms/1000 ft (1000 m)	
Inner	0.32 (1.05)
Outer	0.36 (1.18)
dc Breakdown, volts	6000
Jacket Spark, volts RMS	8000
Capacitance, pF/ft (m)	22.8 (75.0)
Inductance, μH/ft (m)	0.057 (0.187)
Mechanical	
Outer Conductor	Copper
Inner Conductor	Copper
Diameter over Jacket, in (mm)	1.09 (28)
Diameter over Copper Outer Conductor, in (mm)	0.98 (24.9)
Diameter Inner Conductor, in (mm)	0.355 (9.0)
Nominal Inside Transverse Dimensions, cm	2.11
Minimum Bending Radius, in (mm)	10 (250)
Number of Bends, minimum (typical)	15 (50)
Bending Moment, lb-ft (N·m)	12 (16.3)
Cable Weight, lb/ft (kg/m)	0.33 (0.49)
Tensile Strength, lb (kg)	325 (147)
Flat Plate Crush Strength, lb/in (kg/mm)	80 (1.4)

* A 75-ohm 7/8" diameter cable is available. Contact Andrew for further information.

Attenuation and Average Power

Frequency MHz	Attenuation dB/100 ft	Attenuation dB/100 m	Average Power, kW
0.5	0.025	0.081	91.0
1	0.035	0.115	78.6
1.5	0.043	0.141	64.1
2	0.050	0.163	55.5
10	0.112	0.366	24.6
20	0.159	0.521	17.3
30	0.195	0.641	14.1
50	0.254	0.833	10.8
88	0.340	1.12	8.08
100	0.364	1.19	7.56
108	0.378	1.24	7.26
150	0.449	1.47	6.12
174	0.486	1.59	5.66
200	0.523	1.72	5.26
300	0.649	2.13	4.24
400	0.758	2.49	3.63
450	0.808	2.65	3.41
500	0.855	2.81	3.22
512	0.866	2.84	3.17
600	0.945	3.10	2.91
700	1.03	3.37	2.67
800	1.11	3.63	2.48
824	1.13	3.69	2.44
894	1.18	3.87	2.34
960	1.23	4.02	2.24
1000	1.25	4.12	2.19
1250	1.42	4.67	1.93
1500	1.58	5.18	1.74
1700	1.70	5.56	1.62
1800	1.75	5.75	1.57
2000	1.86	6.11	1.48
2100	1.92	6.29	1.44
2200	1.97	6.46	1.40
2300	2.02	6.63	1.36
3000	2.37	7.76	1.16
3400	2.55	8.37	1.08
4000	2.81	9.23	0.978
5000	3.23	10.6	0.853

Standard Conditions:

For Attenuation. VSWR 1.0, ambient temperature 20°C (68°F).

For Average Power. VSWR 1.0, ambient temperature 40°C (104°F), inner conductor temperature 100°C (212°F); no solar loading.

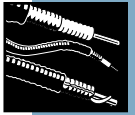

7-16 DIN Female
L5PDF-RPC



7-16 DIN Male
L5PDM-RPC



N Male
L5PNM-RPC



N Female
L5PNF-RPC



7/8" EIA Flange
L45R



F Flange Male
L45F

Connectors

Interface	Description	Type Number	Inner Contact Attachment	Outer Contact Attachment	Plating Code	Max. Length in (mm)	Max. Dia. in (mm)
N Male	OnePiece	L5PNM-RPC	Captivated	Self-Flare	SG	2.9 (74)	1.46 (37.2)
N Male	RingFlare	L5PNM-RC	Captivated	Self-Flare	SG	3.0 (76)	1.35 (34.3)
N Female	OnePiece	L5PNF-RPC	Captivated	Self-Flare	SG	2.7 (69)	1.46 (37.2)
N Female	RingFlare	L5PNF-RC	Captivated	Self-Flare	SG	2.9 (74)	1.35 (34.3)
7-16 DIN Male	OnePiece	L5PDM-RPC	Captivated	Self-Flare	SS	2.7 (69)	1.46 (37.2)
7-16 DIN Male	RingFlare	L5PDM-RC	Captivated	Self-Flare	SS	3.1 (79)	1.34 (34.0)
7-16 DIN Female	OnePiece	L5PDF-RPC	Captivated	Self-Flare	SS	2.33 (59.1)	1.46 (37.2)
7-16 DIN Female	RingFlare	L5PDF-RC	Captivated	RingFlare	SS	2.9 (74)	1.36 (34.5)
7-16 DIN Female	Panel Mount	L5PDF-PM	Self-Tapping	Self-Flare	SS	2.7 (69)	1.35 (34.4)
7-16 DIN Female	Bulkhead	L5PDF-BH	Self-Tapping	Self-Flare	SS	2.7 (69)	1.9 (48.3)
7-16 DIN Male	Right Angle	L5PDR	Self-Tapping	Self-Flare	SS	3.3/2.5 (85/64)	1.4 (35.6)
7/8" EIA Flange	-	L45R	Self-Tapping	Self-Flare	BB	3.3 (84)	2.25 (57)
7/8" EIA Flange	Right Angle	124800-1	Self-Tapping	Self-Flare	BB	3.9/1.3 (99/33)	2.25 (57)
F Flange Male	-	L45F	Self-Tapping	Self-Flare	BB	1.8 (46)	2.25 (57)
F Flange Female	-	48041	Self-Tapping	Self-Flare	BB	1.8 (46)	2.25 (57)
Splice	-	L45Z	Self-Tapping	Self-Flare	BB	3.3 (84)	1.5 (38)

Plating Codes: BB - Brass Body and Pin, BS - Brass Body and Silver Plated Pin, SG - Silver Plated Body and Gold Plated Pin, SS - Silver Plated Body and Pin

Connector Accessories – See page 624



Standard VSWR Specifications

Frequency Band, GHz	Type Number	Assembly VSWR, Maximum (R.L., dB)				
		1-25 ft (0.3-8 m)	25-100 ft (8-30 m)	100-200 ft (30-60 m)	200-500 ft (60-150 m)	Above 500 ft (150 m)
0.806-0.960 and 1.7-2.0	LDF5-50A	1.09 (27.3)*	1.10 (26.4)*	1.11 (25.7)*	1.13 (24.3)*	1.13 (24.3)**
	LDF5RN-50A	1.09 (27.3)*	1.10 (26.4)*	1.11 (25.7)*	1.13 (24.3)*	1.13 (24.3)**

* Expected typical values based on guaranteed 1.13 VSWR for bulk cable and Type N or DIN straight connectors. If guaranteed values are required, contact Andrew.

** 1.13 VSWR guaranteed for bulk standard cable lengths 500 ft and above.

Low VSWR Specifications, Type LDF5P-50A-()

Frequency Band, GHz	Type Number	Using Connector Type*	Assembly VSWR, Maximum (R.L., dB)				
			1-25 ft (0.3-8 m)	25-100 ft (8-30 m)	100-200 ft (30-60 m)	200-500 ft (60-150 m)	Above 500 ft (150 m)
0.780-0.960	LDF5P-50A-10A	N	1.07 (29.4)	1.07 (29.4)	1.08 (28.3)	1.10 (26.4)	1.10 (26.4)
		7-16 DIN	1.07 (29.4)	1.07 (29.4)	1.08 (28.3)	1.10 (26.4)	1.10 (26.4)
0.824-0.960	LDF5P-50A-40	N	1.06 (30.7)	1.07 (29.4)	1.08 (28.3)	1.09 (27.3)	1.10 (26.4)
		7-16 DIN	1.06 (30.7)	1.07 (29.4)	1.08 (28.3)	1.09 (27.3)	1.10 (26.4)
0.806-0.960 and 1.7-2.3	LDF5P-50A-42	N	1.10 (26.4)	1.10 (26.4)	1.10 (26.4)	1.10 (26.4)	1.10 (26.4)
		7-16 DIN	1.10 (26.4)	1.10 (26.4)	1.10 (26.4)	1.10 (26.4)	1.10 (26.4)
0.01-1.0	LDF5P-50A-5A	N	1.10 (26.4)	1.10 (26.4)	1.15 (23.1)	1.20 (20.8)	1.30 (17.7)
		7/8" EIA	1.10 (26.4)	1.10 (26.4)	1.15 (23.1)	1.20 (20.8)	1.30 (17.7)
		7-16 DIN	1.10 (26.4)	1.10 (26.4)	1.15 (23.1)	1.20 (20.8)	1.30 (17.7)
		LC	1.10 (26.4)	1.10 (26.4)	1.15 (23.1)	1.20 (20.8)	1.30 (17.7)
1.38-1.540	LDF5P-50A-11A	N	1.10 (26.4)	1.10 (26.4)	1.12 (24.9)	1.15 (23.1)	1.15 (23.1)
		7/8" EIA	1.10 (26.4)	1.10 (26.4)	1.12 (24.9)	1.15 (23.1)	1.15 (23.1)
		7-16 DIN	1.10 (26.4)	1.10 (26.4)	1.12 (24.9)	1.15 (23.1)	1.15 (23.1)
		F Flange	1.10 (26.4)	1.10 (26.4)	1.12 (24.9)	1.15 (23.1)	1.15 (23.1)
1.7-2.3	LDF5P-50A-41	N	1.10 (26.4)	1.10 (26.4)	1.10 (26.4)	1.10 (26.4)	1.10 (26.4)
		7-16 DIN	1.10 (26.4)	1.10 (26.4)	1.10 (26.4)	1.10 (26.4)	1.10 (26.4)
1.60-2.3	LDF5P-50A-12A	N Male	1.08 (28.3)	1.08 (28.3)	1.10 (26.4)	1.10 (26.4)	1.10 (26.4)
		N Female	1.12 (24.9)	1.12 (24.9)	1.12 (24.9)	1.12 (24.9)	1.12 (24.9)
		7/8" EIA	1.08 (28.3)	1.08 (28.3)	1.10 (26.4)	1.10 (26.4)	1.10 (26.4)
		7-16 DIN	1.08 (28.3)	1.08 (28.3)	1.10 (26.4)	1.10 (26.4)	1.10 (26.4)
		F Flange	1.08 (28.3)	1.08 (28.3)	1.10 (26.4)	1.10 (26.4)	1.10 (26.4)
2.3-2.7	LDF5P-50A-13A	N Male	1.10 (26.4)	1.10 (26.4)	1.12 (24.9)	1.15 (23.1)	1.15 (23.1)
		N Female	1.15 (23.1)	1.15 (23.1)	1.15 (23.1)	1.18 (21.6)	1.18 (21.6)
		7/8" EIA	1.10 (26.4)	1.10 (26.4)	1.12 (24.9)	1.15 (23.1)	1.15 (23.1)
		7-16 DIN	1.10 (26.4)	1.10 (26.4)	1.12 (24.9)	1.15 (23.1)	1.15 (23.1)
		F Flange	1.10 (26.4)	1.10 (26.4)	1.12 (24.9)	1.15 (23.1)	1.15 (23.1)
1.7-4.2	LDF5P-50A-7A	N Male	1.10 (26.4)	1.15 (23.1)	1.20 (20.8)	1.20 (20.8)	1.20 (20.8)
		N Female	1.15 (23.1)	1.20 (20.8)	1.20 (20.8)	1.25 (19.1)	1.25 (19.1)
		7/8" EIA	1.15 (23.1)	1.20 (20.8)	1.20 (20.8)	1.25 (19.1)	1.25 (19.1)
		7-16 DIN Male	1.10 (26.4)	1.15 (23.1)	1.20 (20.8)	1.20 (20.8)	1.20 (20.8)
		7-16 DIN Female	1.15 (23.1)	1.20 (20.8)	1.20 (20.8)	1.25 (19.1)	1.25 (19.1)
0.01-4.2	LDF5P-50A-14A	N Male	1.10 (26.4)	1.20 (20.8)	1.30 (17.7)	1.35 (16.5)	1.35 (16.5)
		N Female	1.15 (23.1)	1.20 (20.8)	1.30 (17.7)	1.35 (16.5)	1.35 (16.5)
		7/8" EIA	1.15 (23.1)	1.20 (20.8)	1.30 (17.7)	1.35 (16.5)	1.35 (16.5)
		7-16 DIN Male	1.10 (26.4)	1.20 (20.8)	1.30 (17.7)	1.35 (16.5)	1.35 (16.5)
		7-16 DIN Female	1.15 (23.1)	1.20 (20.8)	1.30 (17.7)	1.35 (16.5)	1.35 (16.5)
0.01-5.0	LDF5P-50A-15A	N	1.15 (23.1)	1.20 (20.8)	1.35 (16.5)	1.35 (16.5)	1.35 (16.5)
		7/8" EIA	1.30 (17.7)	1.30 (17.7)	1.35 (16.5)	1.35 (16.5)	1.35 (16.5)
		7-16 DIN Male	1.15 (23.1)	1.20 (20.8)	1.35 (16.5)	1.35 (16.5)	1.35 (16.5)
		7-16 DIN Female	1.30 (17.7)	1.30 (17.7)	1.35 (16.5)	1.35 (16.5)	1.35 (16.5)

* Connectors ordered separately

VSWR values apply to straight connectors only, are guaranteed for factory fit assemblies, and are typical for field cut lengths. If two different connector interfaces are selected, the higher VSWR value is guaranteed.

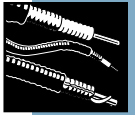

Accessories

Description	Type No.
Hangers – For more hangers, adapters and mounting hardware see pages 599-607	
Standard Hangers Kit of 10. Recommended maximum spacing is 3-ft (1 m). For different spacing recommendations, refer to Cable Hanger Spacing, page 593-598	42396A-5
Hardware Kit of 10. 3/8" bolts, lockwashers, nuts	
3/4" (19mm) long	31769-5
1" (25mm) long	31769-1
Snap-In Hangers Kit of 10. For prepunched 3/4" (19 mm) holes on tower member or adapters. Recommended maximum spacing is 3-ft. For different spacing recommendations, refer to Cable Hanger Spacing, page 593-598	206706A-2
Click-On Hangers Kit of 10. Recommended maximum spacing is 3-ft	L5CLICK
Mounting Hardware see page 605	
Kwik-Clamps Kit of 10. See page 607 for hanger options	
Support/Hoisting Grip. Use at 200-ft (60m) intervals.	
Grip with one clamp	L5SGRIP
Support clamp kit of 10	L5SGRIP-5IK
Standard Hoisting Grip	19256B
Grounding and Surge Protection – for additional grounding kits and our surge protection offerings, see pages 609-616	
SureGround Grounding Kit with standard weatherproofing	
Factory attached one-hole lug, 600 mm (24") lead	SGL5-06B1
Factory attached two-hole lug, 600 mm (24") lead	SGL5-06B2
Field attached two-hole lug, 1500 mm (59") lead	SGL5-15B4
SureGround Plus Grounding Kit with weatherproofing boot	
Factory attached one-hole lug, 600 mm (24") lead	SGPL5-06B1
Factory attached two-hole lug, 600 mm (24") lead	SGPL5-06B2
Field attached two-hole lug, 1500 mm (59") lead	SGPL5-15B4
Arrestor Plus Integrated T-Series Arrestors – see page 614	
Bulkhead N Female	APTL5-BNF-(*)
Bulkhead 7-16 DIN Female	APTL5-BDF-(*)

*Frequency band. See page 614.

Description	Type No.	
Weatherproofing – for additional weatherproofing information see pages 617-618		
WeatherShield™ Connector Protection Housing		
LDF5 to LDF4	WS-L5L4	
LDF5 to FSJ4	WS-L5F4	
Cold Shrink Weatherproofing Kit		
7/8" Coax to 7/8" Coax N Connectors	241474-5	
1-5/8" Coax to 7/8" Coax N Connectors	241475-3	
7/8" Coax to 1/4" Coax	241475-12	
7/8" Coax to 3/8" or 1/2" Coax	241475-9	
7/8" Coax to Antenna Type N or DIN interface	241548-5	
7/8" to APTL5 Arrestors	241474-5	
Connector/Splice Weatherproofing Kit	221213	
Entry Systems – For entry systems offerings see pages 619-620		
Standard Cable Entry Boots	4" Boots	5" Boots
One Hole:	204679A-2	48939A-1
Two Hole:	204679A-18	–
Three Hole:	204679A-15	48939A-2
Tools – for additional tool offerings see pages 620-623		
EASIAx® Plus Automated Cable Prep Tool	CPTL5A	
EASIAx® Cutting Tool	222951	
Cable Flaring Tool	224368	
7/8" Connector Torque Wrench	244378	
DIN Connector Coupling Torque Wrench	244377	
N Connector Coupling Torque Wrench	244379	



1-1/4" Flexible Feeder, Foam Dielectric VXL Series - 50-ohm

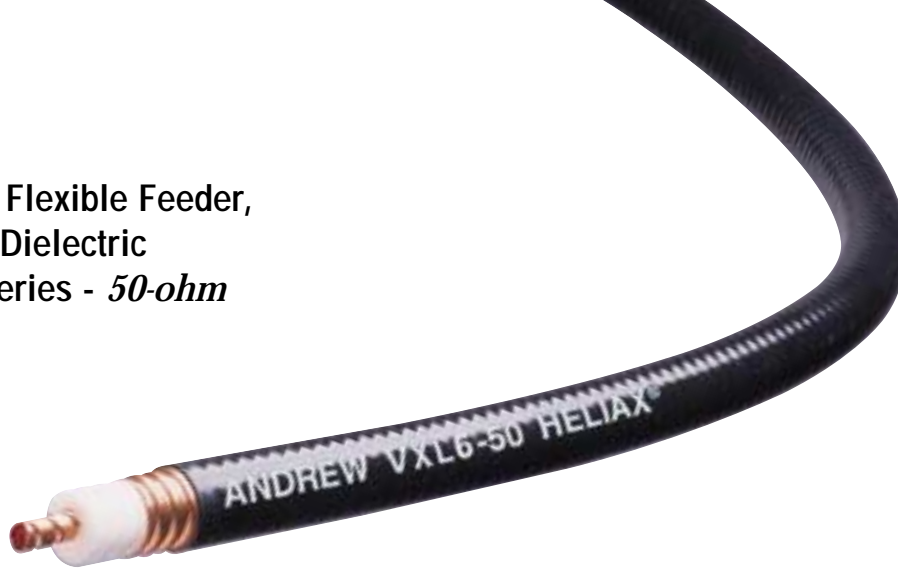

VXL6-50

Description	Type No.
Cable Ordering Information	
Standard Cable	
1-1/4" Standard Cable, Standard Jacket	VXL6-50
Fire Retardant Cable	
1-1/4" Fire Retardant Jacket (CATVR)	VXL6RN-50
Low VSWR and Specialized Cables	
1-1/4" Low VSWR, specify operating band	VXL6P-50-(**)

** Insert suffix number from "Low VSWR Specifications" table, page 511

Characteristics

Electrical	
Impedance, ohms	50 ± 1
Maximum Frequency, GHz	3.3
Velocity, percent	88
Peak Power Rating, kW	180
dc Resistance, ohms/1000 ft (1000 m)	
Inner	0.54 (1.77)
Outer	0.25 (0.82)
dc Breakdown, volts	8500
Jacket Spark, volts RMS	10000
Capacitance, pF/ft (m)	22.6 (74.2)
Inductance, µH/ft (m)	0.05 (0.194)
Mechanical	
Outer Conductor	Copper
Inner Conductor	Copper Tube
Diameter over Jacket, in (mm)	1.55 (39.4)
Diameter over Copper Outer Conductor, in (mm)	1.41 (35.8)
Diameter Inner Conductor, in (mm)	0.536 (13.6)
Minimum Bending Radius, in (mm)	10 (250)
Number of Bends, minimum (typical)	15 (50)
Bending Moment, lb-ft (Nm)	22 (30.4)
Cable Weight, lb/ft (kg/m)	0.5 (0.74)
Tensile Strength, lb (kg)	400 (181)
Flat Plate Crush Strength, lb/in (kg/mm)	75 (1.3)

Attenuation and Average Power

Frequency MHz	Attenuation dB/100 ft	Attenuation dB/100 m	Average Power kW
0.5	0.018	0.060	154.35
1	0.026	0.085	108.94
1.5	0.032	0.104	88.83
2	0.037	0.121	76.84
10	0.083	0.273	34.00
20	0.119	0.389	23.85
30	0.146	0.479	19.36
50	0.190	0.625	14.86
88	0.256	0.840	11.05
100	0.274	0.899	10.33
108	0.285	0.936	9.9
150	0.340	1.12	8.32
174	0.368	1.21	7.69
200	0.397	1.30	7.13
300	0.495	1.62	5.72
400	0.580	1.90	4.88
450	0.619	2.03	4.57
500	0.657	2.15	4.31
512	0.666	2.18	4.25
600	0.728	2.39	3.89
700	0.795	2.61	3.56
800	0.858	2.81	3.30
824	0.872	2.86	3.25
894	0.914	3.00	3.10
960	0.953	3.13	2.97
1000	0.976	3.20	2.90
1250	1.11	3.65	2.55
1500	1.24	4.07	2.29
1700	1.34	4.38	2.12
1800	1.38	4.54	2.05
2000	1.47	4.83	1.92
2100	1.52	4.98	1.87
2200	1.56	5.12	1.81
2300	1.61	5.27	1.76
3000	1.89	6.21	1.50
3300	2.01	6.59	1.41

Standard Conditions:

For Attenuation, VSWR 1.0 ambient temperature 20°C (68°F). For Average Power, VSWR 1.0, ambient temperature 40°C (104°F), inner conductor temperature 100°C (212°F), no solar loading.

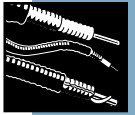

N Male
V6PNM-RPC



N Female
V6PNF-RPC



7-16 DIN Male
V6PDM-RPC



7-16 DIN Female
V6PDF-RPC

Connectors

Interface	Description	Type Number	Inner Contact Attachment	Outer Contact Attachment	Plating Code	Max. Length in (mm)	Max. Dia. in (mm)
N Male	OnePiece	V6PNM-RPC	Captivated	Self-Flare	SG	3.3 (84)	2.03 (51.6)
N Female	OnePiece	V6PNF-RPC	Captivated	Self-Flare	SG	4.0 (102)	2.03 (51.6)
7-16 DIN Male	OnePiece	V6PDM-RPC	Captivated	Self-Flare	SS	3.6 (91)	2.03 (51.6)
7-16 DIN Female	OnePiece	V6PDF-RPC	Captivated	Self-Flare	SS	3.5 (89)	2.03 (51.6)

Plating Codes: SG - Silver Plated Body and Gold Plated Pin. SS - Silver Plated Body and Pin.

Connector Accessories - See page 624

Standard VSWR Specifications

Frequency Band, GHz	Type No.	Assembly VSWR, Maximum (R.L., dB)				
		1-25 ft (3-8 m)	25-100 ft (8-30 m)	100-200 ft (30-60 m)	200-500 ft (60-150m)	Above 500 ft (150 m)
0.806-0.960	VXL6-50	1.10 (26.4)*	1.11 (25.7)*	1.12 (24.9)*	1.13 (24.3)*	1.13 (24.3)**
and 1.7-2.0	VXL6RN-50	1.10 (26.4)*	1.11 (25.7)*	1.12 (24.9)*	1.13 (24.3)*	1.13 (24.3)**

* Expected typical values based on guaranteed 1.13 VSWR for bulk cable and Type N or DIN straight connectors. If guaranteed values are required, contact Andrew.

** 1.13 VSWR guaranteed for bulk standard cable lengths 500 ft and above.

Low VSWR Specifications, Type VXL6P-50-()

Frequency Band, GHz	Type No.	Using Connector Type*	Assembly VSWR, Maximum (R.L., dB)				
			1 to 25 ft (0.3-8 m)	25-100 ft (8-30 m)	100-200 ft (30-60 m)	200-500 ft (60-150 m)	Above 500 ft (150 m)
0.806-0.960	VXL6P-50-40	N	1.08 (28.3)	1.08 (28.3)	1.08 (28.3)	1.09 (27.3)	1.10 (26.4)
		7-16 DIN	1.08 (28.3)	1.08 (28.3)	1.08 (28.3)	1.09 (27.3)	1.10 (26.4)
0.806-0.960 and 1.7-2.3	VXL6P-50-42	N	1.10 (26.4)	1.10 (26.4)	1.10 (26.4)	1.10 (26.4)	1.10 (26.4)
		7-16 DIN	1.10 (26.4)	1.10 (26.4)	1.10 (26.4)	1.10 (26.4)	1.10 (26.4)
1.7-2.3	VXL6P-50-41	N	1.10 (26.4)	1.10 (26.4)	1.10 (26.4)	1.10 (26.4)	1.10 (26.4)
		7-16 DIN	1.10 (26.4)	1.10 (26.4)	1.10 (26.4)	1.10 (26.4)	1.10 (26.4)

* Connectors ordered separately.

VSWR values apply to straight connectors only, are guaranteed for factory fit assemblies, and are typical for field cut lengths. If two different connector interfaces are selected, the higher VSWR value is guaranteed.



Accessories

Description	Type No.
Hangers – For more hangers, adapters and mounting hardware see pages 599-607	
Standard Hangers Kit of 10. Standard tower configuration spacing is 3-4 feet (1-1.2 m). For different spacing recommendations, refer to Cable Hanger Spacing, page 593-598	42396A-1
Hardware Kit of 10. 3/8" bolts, lockwashers, nuts	
3/4" (19mm) long	31769-5
1" (25mm) long	31769-1
Snap-In Hangers Kit of 10. For prepunched 3/4" (19mm) holes on tower member or adapters, Recommended maximum spacing is 3-ft. For different spacing recommendations, refer to Cable Hanger Spacing, page 593-598	206706-3
Click-On Hangers Kit of 10. Recommended maximum spacing is 3-ft Mounting Hardware see page 605	L6CLICK
Kwik-Clamps Kit of 10. See page 607 for hanger options	
Support/Hoisting Grip. Use at 200-ft (60m) intervals.	
Grip with one clamp	L6SGRIP
Support clamp kit of 10	L6SGRIP-6IK
Standard Hoisting Grip	29961
Grounding and Surge Protection – for additional grounding kits and our surge protection offerings, see pages 609-616	
SureGround Grounding Kit with standard weatherproofing	
Factory attached one-hole lug, 600 mm (24") lead	SGL6-06B1
Factory attached two-hole lug, 600 mm (24") lead	SGL6-06B2
Field attached two-hole lug, 1500 mm (59") lead	SGL6-15B4
SureGround Plus Grounding Kit with weatherproofing boot	
Factory attached one-hole lug, 600 mm (24") lead	SGPL6-06B1
Factory attached two-hole lug, 600 mm (24") lead	SGPL6-06B2
Field attached two-hole lug, 1500 mm (59") lead	SGPL6-15B4

Description	Type No.	
Weatherproofing – for additional weatherproofing information see pages 617-618		
WeatherShield™ Connector Protection Housing		
VXL6 to LDF4	WS-L6L4	
VXL6 to FSJ4	WS-L6F4	
Cold Shrink Weatherproofing Kit		
1-1/4" Coax to 1-1/4" Coax N Connectors	241474-6	
1-1/4" Coax to 1/4" Coax	241475-11	
1-1/4" Coax to 3/8" or 1/2" Coax	241475-5A	
1-1/4" to APTL6 Arrestors	241474-6	
Connector/Splice Weatherproofing Kit	221213	
Entry Systems – For entry systems offerings see pages 619-620		
Standard Cable Entry Boots	4" Boots	5" Boots
One Hole:	204679A-3	48939A-2
Tools – for additional tool offerings see pages 620-623		
EASIX [®] Plus Automated Cable Prep Tool	CPTL6	
1-1/4" Connector Torque Wrench	244375	
DIN Connector Coupling Torque Wrench	244377	
N Connector Coupling Torque Wrench	244379	



1-1/4" Foam Dielectric, LDF Series – 50-ohm



HELIAIX® Coaxial Cables

LDF6-50

Description	Type No.
Cable Ordering Information	
Standard Cable	
1-1/4" Standard Cable, Standard Jacket	LDF6-50
Fire Retardant Cable	
1-1/4" Fire Retardant Jacket (CATVR)	LDF6RN-50
Low VSWR and Specialized Cables	
1-1/4" Low VSWR, specify operating band	LDF6P-50-(**)

** Insert suffix number from "Low VSWR Specifications" table, page 515

Characteristics

Electrical	
Impedance, ohms	50 ± 1
Maximum Frequency, GHz	3.3
Velocity, percent	89
Peak Power Rating, kW	205
dc Resistance, ohms/1000 ft (1000 m)	
Inner	0.22 (0.72)
Outer	0.19 (0.62)
dc Breakdown, volts	9000
Jacket Spark, volts RMS	10000
Capacitance, pF/ft (m)	22.9 (75.1)
Inductance, µH/ft (m)	0.056 (0.184)
Mechanical	
Outer Conductor	Copper
Inner Conductor	Copper
Diameter over Jacket, in (mm)	1.55 (39.4)
Diameter over Copper Outer Conductor, in (mm)	1.41 (35.8)
Diameter Inner Conductor, in (mm)	0.516 (13.1)
Nominal Inside Transverse Dimensions, cm	3.11
Minimum Bending Radius, in (mm)	15 (380)
Number of Bends, minimum (typical)	15 (40)
Bending Moment, lb-ft (N·m)	36 (49)
Cable Weight, lb/ft (kg/m)	0.63 (0.94)
Tensile Strength, lb (kg)	1300 (590)
Flat Plate Crush Strength, lb/in (kg/mm)	125 (2.2)

Attenuation and Average Power

Frequency MHz	Attenuation dB/100 ft	Attenuation dB/100 m	Average Power, kW
0.5	0.017	0.056	175.0
1	0.024	0.079	123.0
1.5	0.030	0.097	101.0
2	0.034	0.112	87.1
10	0.077	0.253	38.6
20	0.110	0.361	27.1
30	0.135	0.444	22.0
50	0.176	0.579	16.9
88	0.237	0.778	12.6
100	0.254	0.832	11.7
108	0.264	0.867	11.3
150	0.314	1.03	9.47
174	0.340	1.12	8.75
200	0.367	1.20	8.12
300	0.457	1.50	6.52
400	0.535	1.76	5.57
450	0.571	1.87	5.22
500	0.606	1.99	4.92
512	0.614	2.01	4.86
600	0.671	2.20	4.44
700	0.732	2.40	4.07
800	0.789	2.59	3.78
824	0.803	2.63	3.71
894	0.841	2.76	3.54
960	0.876	2.87	3.40
1000	0.897	2.94	3.32
1250	1.02	3.35	2.92
1500	1.14	3.73	2.62
1700	1.22	4.02	2.43
1800	1.27	4.16	2.35
2000	1.35	4.43	2.21
2100	1.39	4.56	2.14
2200	1.43	4.69	2.08
2300	1.47	4.82	2.03
3000	1.73	5.68	1.72
3300	1.84	6.02	1.62

Standard Conditions:

For Attenuation. VSWR 1.0, ambient temperature 20°C (68°F).

For Average Power. VSWR 1.0, ambient temperature 40°C (104°F), inner conductor temperature 100°C (212°F); no solar loading.



Connectors

Interface	Description	Type Number	Inner Contact Attachment	Outer Contact Attachment	Plating Code	Max. Length in (mm)	Max. Dia. in (mm)
N Male	OnePiece	L6PNM-RPC	Captivated	Self-Flare	SG	3.8 (96)	2.03 (51.6)
N Female	OnePiece	L6PNF-RPC	Captivated	Self-Flare	SG	3.1 (79)	2.03 (51.6)
N Female	RingFlare	L6PNF-RC	Captivated	Self-Flare	SG	3.4 (86)	2.0 (50.8)
7-16 DIN Male	OnePiece	L6PDM-RPC	Captivated	Self-Flare	SS	3.4 (86)	2.03 (51.6)
7-16 DIN Female	OnePiece	L6PDF-RPC	Captivated	Self-Flare	SS	3.4 (86)	2.03 (51.6)
7-16 DIN Female	Bulkhead	L6PDF-BH	Self-Tapping	Self-Flare	SS	4.1 (104)	2.0 (50.8)
7-16 DIN Female	RingFlare	L6PDF-RC	Captivated	Self-Flare	SS	3.2 (81)	2.0 (50.8)
7/8" EIA Flange	–	L46S	Self-Tapping	Self-Flare	BB	4.6 (117)	2.25 (57)
1-5/8" EIA Flange	–	L46R	Self-Tapping	Self-Flare	BB	5.1 (130)	3.5 (89)
F Flange Male	–	L46F	Self-Tapping	Self-Flare	BB	4.0 (102)	2.25 (57)
Splice	–	L46Z	Self-Tapping	Self-Flare	BB	3.0 (76)	2.0 (50.8)

Plating Codes: BB - Brass Body and Pin, SG - Silver Plated Body and Gold Plated Pin, SS - Silver Plated Body and Pin

Connector Accessories – See page 624

Factory Attached Connectors – For factory made cable assemblies and jumper cables, see pages 584-587.

Standard VSWR Specifications

Frequency Band, GHz	Type Number	Assembly VSWR, Maximum (R.L., dB)				
		1-25 ft (0.3-8 m)	25-100 ft (8-30 m)	100-200 ft (30-60 m)	200-500 ft (60-150m)	Above 500 ft (150 m)
0.806-0.960 and 1.7-2.0	LDF6-50	1.10 (26.4)*	1.11 (25.7)*	1.12 (24.97)*	1.13 (24.3)*	1.13 (24.3)**
	LDF6RN-50	1.10 (26.4)*	1.11 (25.7)*	1.12 (24.97)*	1.13 (24.3)*	1.13 (24.3)**

* Expected typical values based on guaranteed 1.13 VSWR for bulk cable and Type N or DIN straight connectors. If guaranteed values are required, contact Andrew.

** 1.13 VSWR guaranteed for bulk standard cable lengths 500 ft and above.

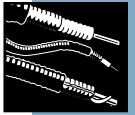

Low VSWR Specifications, Type LDF6P-50-()

Frequency Band, GHz	Type Number	Using Connector Type*	Assembly VSWR, Maximum (R.L., dB)				
			1-25 ft (0.3-8 m)	25-100 ft (8-30 m)	100-200 ft (30-60 m)	200-500 ft (60-150 m)	Above 500 ft (150 m)
0.806-0.960	LDF6P-50-40	N	1.07 (29.4)	1.08 (28.3)	1.08 (28.3)	1.09 (27.3)	1.10 (26.4)
		7-16 DIN	1.07 (29.4)	1.08 (28.3)	1.08 (28.3)	1.09 (27.3)	1.10 (26.4)
0.806-0.960 and 1.7-2.3	LDF6P-50-42	N	1.10 (26.4)	1.10 (26.4)	1.10 (26.4)	1.10 (26.4)	1.10 (26.4)
		7-16 DIN	1.10 (26.4)	1.10 (26.4)	1.10 (26.4)	1.10 (26.4)	1.10 (26.4)
1.427-1.535	LDF6P-50-4A	7/8" EIA	1.06 (30.7)	1.08 (28.3)	1.10 (26.4)	1.17 (22.1)	1.20 (20.8)
		N Male	1.08 (28.3)	1.10 (26.4)	1.12 (24.9)	1.15 (23.1)	1.15 (23.1)
		"F" Flange	1.10 (26.4)	1.12 (24.9)	1.15 (23.1)	1.20 (20.8)	1.25 (19.1)
		7-16 DIN Male	1.10 (26.4)	1.15 (23.1)	1.20 (20.8)	1.20 (20.8)	1.25 (19.1)
		7-16 DIN Female	1.08 (28.3)	1.10 (26.4)	1.12 (24.9)	1.15 (23.1)	1.20 (20.8)
		N Female	1.10 (26.4)	1.12 (24.9)	1.15 (23.1)	1.20 (20.8)	1.25 (19.1)
		LC Male	1.20 (20.8)	1.25 (19.1)	1.28 (18.2)	1.30 (17.7)	1.30 (17.7)
		LC Female	1.20 (20.8)	1.25 (19.1)	1.30 (17.7)	1.30 (17.7)	1.30 (17.7)
		1-5/8" EIA	1.10 (26.4)	1.15 (23.1)	1.20 (20.8)	1.20 (20.8)	1.25 (19.1)
1.7-2.3	LDF6P-50-41	N	1.09 (27.3)	1.09 (27.3)	1.10 (26.4)	1.10 (26.4)	1.10 (26.4)
		7-16 DIN	1.09 (27.3)	1.09 (27.3)	1.10 (26.4)	1.10 (26.4)	1.10 (26.4)
1.7-2.11	LDF6P-50-6A	7/8" EIA	1.06 (30.7)	1.08 (28.3)	1.10 (26.4)	1.12 (24.9)	1.15 (23.1)
		N Male	1.08 (28.3)	1.10 (26.4)	1.12 (24.9)	1.15 (23.1)	1.15 (23.1)
		"F" Flange	1.10 (26.4)	1.12 (24.9)	1.15 (23.1)	1.18 (21.6)	1.20 (20.8)
		7-16 DIN Male	1.10 (26.4)	1.12 (24.9)	1.15 (23.1)	1.18 (21.6)	1.20 (20.8)
		7-16 DIN Female	1.08 (28.3)	1.10 (26.4)	1.12 (24.9)	1.15 (23.1)	1.15 (23.1)
		N Female	1.10 (26.4)	1.12 (24.9)	1.15 (23.1)	1.18 (21.6)	1.20 (20.8)
		LC	1.20 (20.8)	1.22 (20.1)	1.24 (19.3)	1.25 (19.1)	1.25 (19.1)
		1-5/8" EIA	1.10 (26.4)	1.15 (23.1)	1.18 (21.6)	1.20 (20.8)	1.20 (20.8)
		1.85-2.2	LDF6P-50-7A	7/8" EIA	1.06 (30.7)	1.08 (28.3)	1.10 (26.4)
N Male	1.06 (30.7)			1.08 (28.3)	1.10 (26.4)	1.12 (24.9)	1.15 (23.1)
"F" Flange	1.08 (28.3)			1.10 (26.4)	1.12 (24.9)	1.15 (23.1)	1.15 (23.1)
7-16 DIN Male	1.08 (28.3)			1.10 (26.4)	1.12 (24.9)	1.15 (23.1)	1.15 (23.1)
7-16 DIN Female	1.06 (30.7)			1.08 (28.3)	1.10 (26.4)	1.12 (24.9)	1.15 (23.1)
N Female: L6PNF	1.08 (28.3)			1.10 (26.4)	1.12 (24.9)	1.15 (23.1)	1.15 (23.1)
LC	1.20 (20.8)			1.22 (20.1)	1.24 (19.3)	1.25 (19.1)	1.25 (19.1)
1-5/8" EIA	1.10 (26.4)			1.12 (24.9)	1.14 (23.7)	1.18 (21.6)	1.20 (20.8)*
1.9-2.3	LDF6P-50-8A			7/8" EIA	1.08 (28.3)	1.10 (26.4)	1.12 (24.9)
		N Male	1.08 (28.3)	1.10 (26.4)	1.12 (24.9)	1.15 (23.1)	1.15 (23.1)
		"F" Flange	1.10 (26.4)	1.12 (24.9)	1.15 (23.1)	1.18 (21.6)	1.20 (20.8)
		7-16 DIN Male	1.12 (24.9)	1.22 (20.1)	1.24 (19.3)	1.25 (19.1)	1.25 (19.1)
		7-16 DIN Female	1.08 (28.3)	1.10 (26.4)	1.12 (24.9)	1.15 (23.1)	1.20 (20.8)
		N Female	1.12 (24.9)	1.15 (23.1)	1.18 (21.6)	1.25 (19.1)	1.25 (19.1)
		LC Male	1.20 (20.8)	1.22 (20.1)	1.25 (19.1)	1.28 (18.2)	1.30 (17.7)
		LC Female	1.20 (20.8)	1.25 (19.1)	1.28 (18.2)	1.30 (17.7)	1.35 (16.6)
		1-5/8" EIA	1.20 (20.8)	1.22 (20.1)	1.24 (19.4)	1.25 (19.1)	1.25 (19.1)
2.3-2.7	LDF6P-50-9A	7/8" EIA	1.08 (28.3)	1.10 (26.4)	1.12 (24.9)	1.15 (23.1)	1.20 (20.8)
		N Male	1.08 (28.3)	1.10 (26.4)	1.15 (23.1)	1.18 (21.6)	1.20 (20.8)
		"F" Flange	1.10 (26.4)	1.12 (24.9)	1.15 (23.1)	1.20 (20.8)	1.25 (19.1)
		7-16 DIN Male	1.10 (26.4)	1.12 (24.9)	1.15 (23.1)	1.20 (20.8)	1.25 (19.1)
		7-16 DIN Female	1.08 (28.3)	1.10 (26.4)	1.12 (24.9)	1.15 (23.1)	1.20 (20.8)
		N Female	1.10 (26.4)	1.12 (24.9)	1.15 (23.1)	1.20 (20.8)	1.25 (19.1)
		LC Female	1.30 (17.7)	1.30 (17.7)	1.32 (17.2)	1.35 (16.6)	1.35 (16.6)
		LC Male	1.20 (20.8)	1.22 (20.1)	1.25 (19.1)	1.28 (18.2)	1.30 (17.7)
		1-5/8" EIA	1.20 (20.8)	1.20 (20.8)	1.22 (20.1)	1.25 (19.1)	1.25 (19.1)
0.010-2.7	LDF6P-50-10A	7/8" EIA	1.10 (26.4)	1.20 (20.8)	1.35 (16.6)	2.10 (9.0)	2.10 (9.0)
		N	1.10 (26.4)	1.20 (20.8)	1.35 (16.6)	2.10 (9.0)	2.10 (9.0)
		"F" Flange	1.10 (26.4)	1.20 (20.8)	1.35 (16.6)	2.10 (9.0)	2.10 (9.0)
		7-16 DIN	1.10 (26.4)	1.20 (20.8)	1.35 (16.6)	1.80 (10.9)	2.10 (9.0)
		LC Female	1.30 (17.7)	1.35 (16.6)	1.40 (15.6)	1.80 (10.9)	2.10 (9.0)
		LC Male	1.20 (20.8)	1.25 (19.1)	1.35 (16.6)	1.80 (10.9)	2.10 (9.0)
		1-5/8" EIA	1.20 (20.8)	1.30 (17.7)	1.35 (16.6)	1.80 (10.9)	2.10 (9.0)
0.010-3.3	LDF6P-50-11A	7/8" EIA	1.10 (26.4)	1.20 (20.8)	1.35 (16.6)	1.80 (10.9)	2.10 (9.0)
		N Male	1.10 (26.4)	1.20 (20.8)	1.35 (16.6)	2.10 (9.0)	2.10 (9.0)
		"F" Flange	1.10 (26.4)	1.20 (20.8)	1.35 (16.6)	1.80 (10.9)	2.10 (9.0)
		7-16 DIN	1.10 (26.4)	1.20 (20.8)	1.35 (16.6)	1.80 (10.9)	2.10 (9.0)
		N Female	1.10 (26.4)	1.20 (20.8)	1.35 (16.6)	2.10 (9.0)	2.10 (9.0)
		LC	1.30 (17.7)	1.40 (15.6)	1.50 (14.0)	1.80 (10.9)	2.10 (9.0)

* Connectors ordered separately

VSWR values apply to straight connectors only, are guaranteed for factory fit assemblies, and are typical for field cut lengths. If two different connector interfaces are selected, the higher VSWR value is guaranteed.



Accessories

Description	Type No.
Hangers – For more hangers, adapters and mounting hardware see pages 599-607	
Standard Hangers Kit of 10. Standard tower configuration spacing is 3-4 feet (1-1.2 m). For different spacing recommendations, refer to Cable Hanger Spacing, page 593-598	42396A-1
Hardware Kit of 10. 3/8" bolts, lockwashers, nuts	
3/4" (19mm) long	31769-5
1" (25mm) long	31769-1
Snap-In Hangers Kit of 10. For prepunched 3/4" (19mm) holes on tower member or adapters, Recommended maximum spacing is 3-ft. For different spacing recommendations, refer to Cable Hanger Spacing, page 593-598	206706-3
Click-On Hangers Kit of 10. Recommended maximum spacing is 3-ft Mounting Hardware see page 605	L6CLICK
Kwik-Clamps Kit of 10. See page 607 for hanger options	
Support/Hoisting Grip. Use at 200-ft (60m) intervals.	
Grip with one clamp	L6SGRIP
Support clamp kit of 10	L6SGRIP-6IK
Standard Hoisting Grip	29961
Grounding and Surge Protection – for additional grounding kits and our surge protection offerings, see pages 609-616	
SureGround Grounding Kit with standard weatherproofing	
Factory attached one-hole lug, 600 mm (24") lead	SGL6-06B1
Factory attached two-hole lug, 600 mm (24") lead	SGL6-06B2
Field attached two-hole lug, 1500 mm (59") lead	SGL6-15B4
SureGround Plus Grounding Kit with weatherproofing boot	
Factory attached one-hole lug, 600 mm (24") lead	SGPL6-06B1
Factory attached two-hole lug, 600 mm (24") lead	SGPL6-06B2
Field attached two-hole lug, 1500 mm (59") lead	SGPL6-15B4
Arrestor Plus Integrated T-Series Arrestors – see page 614	
Bulkhead N Female	APTL6-BNF-(*)
Bulkhead 7-16 DIN Female	APTL6-BDF-(*)

* Frequency band. See page 614

Description	Type No.
Weatherproofing – for additional weatherproofing information see pages 617-618	
WeatherShield™ Connector Protection Housing	
LDF6 to LDF4	WS-L6L4
LDF6 to FSJ4	WS-L6F4
Cold Shrink Weatherproofing Kit	
1-1/4" Coax to 1-1/4" Coax N Connectors	241474-6
1-1/4" Coax to 1/4" Coax	241475-11
1-1/4" Coax to 3/8" or 1/2" Coax	241475-5A
1-1/4" to APTL6 Arrestors	241474-6
Connector/Splice Weatherproofing Kit 221213	
Entry Systems – For entry systems offerings see pages 619-620	
Standard Cable Entry Boots	4" Boots 5" Boots
One Hole:	204679A-3 48939A-2
Tools – for additional tool offerings see pages 620-623	
EASIX [®] Plus Automated Cable Prep Tool	CPTL6
1-1/4" Connector Torque Wrench	244375
DIN Connector Coupling Torque Wrench	244377
N Connector Coupling Torque Wrench	244379

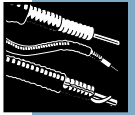

1-5/8" Flexible Feeder, Foam Dielectric VXL Series - 50-ohm



HELIAX® Coaxial Cables

VXL7-50

Description	Type No.
Cable Ordering Information	
Standard Cable	
1-5/8" Standard Cable, Standard Jacket	VXL7-50
Fire Retardant Cable	
1-5/8" Fire Retardant Jacket (CATVR)	VXL7RN-50
Low VSWR and Specialized Cables	
1-5/8" Low VSWR, specify operating band	VXL7P-50-(**)
** Insert suffix number from "Low VSWR Specifications" table, page 518	
Characteristics	
Electrical	
Impedance, ohms	50 ± 1
Maximum Frequency, GHz	2.5
Velocity, percent	88
Peak Power Rating, kW	275
dc Resistance, ohms/1000 ft (1000 m)	
Inner	0.42 (1.39)
Outer	0.16 (0.52)
dc Breakdown, volts	10500
Jacket Spark, volts RMS	10000
Capacitance, pF/ft (m)	22.5 (73.8)
Inductance, µH/ft (m)	0.05 (0.194)
Mechanical	
Outer Conductor	Copper
Inner Conductor	Copper Tube
Diameter over Jacket, in (mm)	1.98 (50)
Diameter over Copper Outer Conductor, in (mm)	1.825 (46.3)
Diameter Inner Conductor, in (mm)	0.688 (17.5)
Minimum Bending Radius, in (mm)	15 (375)
Number of Bends, minimum (typical)	15 (50)
Bending Moment, lb-ft (Nm)	35 (48.4)
Cable Weight, lb/ft (kg/m)	0.75 (1.12)
Tensile Strength, lb (kg)	550 (249)
Flat Plate Crush Strength, lb/in (kg/mm)	110 (2.0)

Attenuation and Average Power

Frequency MHz	Attenuation dB/100 ft	Attenuation dB/100 m	Average Power, kW
0.5	0.014	0.044	247.0
1	0.019	0.063	175.0
1.5	0.024	0.077	142.0
2	0.027	0.089	123.0
10	0.062	0.202	54.3
20	0.088	0.289	38.1
30	0.109	0.356	30.9
50	0.142	0.465	23.6
88	0.191	0.627	17.5
100	0.205	0.671	16.4
108	0.213	0.699	15.7
150	0.254	0.834	13.2
174	0.276	0.904	12.2
200	0.297	0.976	11.3
300	0.372	1.22	9.01
400	0.437	1.43	7.67
450	0.467	1.53	7.18
500	0.496	1.63	6.76
512	0.503	1.65	6.67
600	0.550	1.81	6.09
700	0.602	1.97	5.57
800	0.650	2.13	5.15
824	0.662	2.17	5.06
894	0.694	2.28	4.83
960	0.724	2.38	4.63
1000	0.742	2.43	4.52
1250	0.848	2.78	3.95
1500	0.947	3.11	3.54
1700	1.02	3.35	3.28
2000	1.13	3.71	2.96
2300	1.23	4.05	2.72
2500	1.30	4.27	2.58

Standard Conditions:

For Attenuation. VSWR 1.0 ambient temperature 20°C (68°F). For Average Power, VSWR 1.0, ambient temperature 40°C (104°F), inner conductor temperature 100°C (212°F), no solar loading.

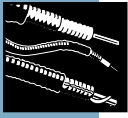

N Male
V7PNM-RPC



N Female
V7PNF-RPC



7-16 DIN Female
V7PDF-RPC



7-16 DIN Male
V7PDM-RPC

Connectors

Interface	Description	Type Number	Inner Contact Attachment	Outer Contact Attachment	Plating Code	Max.Length in (mm)	Max.Dia. in (mm)
N Male	OnePiece	V7PNM-RPC	Captivated	Self-Flare	SG	4.6 (117)	2.47 (62.7)
N Female	OnePiece	V7PNF-RPC	Captivated	Self-Flare	SG	4.7 (119)	2.47 (62.7)
7-16 DIN Male	OnePiece	V7PDM-RPC	Captivated	Self-Flare	SS	4.3 (109)	2.46 (62.5)
7-16 DIN Female	OnePiece	V7PDF-RPC	Captivated	Self-Flare	SS	4.3 (109)	2.46 (62.5)

Plating Codes: SG - Silver Plated Body and Gold Plated Pin. SS - Silver Plated Body and Pin.

Connector Accessories - See page 624

Standard VSWR Specifications

Frequency Band, GHz	Type No.	Assembly VSWR, Maximum (R.L., dB)				
		1-25 ft (3-8 m)	25-100 ft (8-30 m)	100-200 ft (30-60 m)	200-500 ft (60-150 m)	Above 500 ft (150 m)
0.806-0.960 and 1.7-2.0	VXL7-50	1.10 (26.4)*	1.10 (26.4)*	1.12 (24.9)*	1.13 (24.3)*	1.13 (24.3)**
	VXL7RN-50	1.10 (26.4)*	1.10 (26.4)*	1.12 (24.9)*	1.13 (24.3)*	1.13 (24.3)**

* Expected typical values based on guaranteed 1.13 VSWR for bulk cable and Type N or DIN straight connectors. If guaranteed values are required, contact Andrew.
 ** 1.13 VSWR guaranteed for bulk standard cable lengths 500 ft and above.

Low VSWR Specifications, Type VXL7P-50-()

Frequency Band, GHz	Type No.	Using Connector Type*	Assembly VSWR, Maximum (R.L., dB)				
			1 to 25 ft (0.3-8 m)	25-100 ft (8-30 m)	100-200 ft (30-60 m)	200-500 ft (60-150 m)	Above 500 ft (150 m)
0.806-0.960	VXL7P-50-40	N	1.07 (29.4)	1.08 (28.3)	1.08 (28.3)	1.09 (27.3)	1.10 (26.4)
		7-16 DIN	1.07 (29.4)	1.08 (28.3)	1.08 (28.3)	1.09 (27.3)	1.10 (26.4)
0.806-0.960 and 1.7-2.3	VXL7P-50-42	N	1.10 (26.4)	1.10 (26.4)	1.10 (26.4)	1.10 (26.4)	1.10 (26.4)
		7-16 DIN	1.10 (26.4)	1.10 (26.4)	1.10 (26.4)	1.10 (26.4)	1.10 (26.4)
1.7-2.3	VXL7P-50-41	N	1.10 (26.4)	1.10 (26.4)	1.10 (26.4)	1.10 (26.4)	1.10 (26.4)
		7-16 DIN	1.10 (26.4)	1.10 (26.4)	1.10 (26.4)	1.10 (26.4)	1.10 (26.4)

* Connectors ordered separately.

VSWR values apply to straight connectors only, are guaranteed for factory fit assemblies, and are typical for field cut lengths. If two different connector interfaces are selected, the higher VSWR value is guaranteed.



Accessories

Description	Type No.
Hangers – For more hangers, adapters and mounting hardware see pages 599-607	
Standard Hangers Kit of 10. Standard tower configuration spacing is 3-4 feet (1-1.2 m). For different spacing recommendations, refer to Cable Hanger Spacing, page 593-598	42396A-2
Hardware Kit of 10. 3/8" bolts, lockwashers, nuts	
3/4" (19mm) long	31769-5
1" (25mm) long	31769-1
Snap-In Hangers Kit of 10. For prepunched 3/4" (19mm) holes on tower member or adapters, Recommended maximum spacing is 3-ft. For different spacing recommendations, refer to Cable Hanger Spacing, page 593-598	206706-4
Click-On Hangers Kit of 10. Recommended maximum spacing is 3-ft	L7CLICK
Mounting Hardware see page 605	
Kwik-Clamps Kit of 10. See page 607 for hanger options	
Support/Hoisting Grip. Use at 200-ft (60m) intervals.	
Grip with one clamp	L7SGRIP
Support clamp kit of 10	L7SGRIP-7IK
Standard Hoisting Grip	24312A

Grounding and Surge Protection – for additional grounding kits and our surge protection offerings, see pages 609-616

SureGround Grounding Kit with standard weatherproofing	
Factory attached one-hole lug, 600 mm (24") lead	SGL7-06B1
Factory attached two-hole lug, 600 mm (24") lead	SGL7-06B2
Field attached two-hole lug, 1500 mm (59") lead	SGL7-15B4
SureGround Plus Grounding Kit with weatherproofing boot	
Factory attached one-hole lug, 600 mm (24") lead	SGPL7-06B1
Factory attached two-hole lug, 600 mm (24") lead	SGPL7-06B2
Field attached two-hole lug, 1500 mm (59") lead	SGPL7-15B4

Description	Type No.	
Weatherproofing – for additional weatherproofing information see pages 617-618		
WeatherShield™ Connector Protection Housing		
VXL7 to LDF4	WS-L7L4	
VXL7 to FSJ4	WS-L7F4	
Cold Shrink Weatherproofing Kit		
1-5/8" Coax to 1-1/4" Coax N Connectors	241474-6	
1-5/8" Coax to 1/4" Coax	241475-11	
1-5/8" Coax to 3/8" or 1/2" Coax	241475-5A	
1-5/8" to APTL7 Arrestors	241474-6	
Connector/Splice Weatherproofing Kit	221213	
Entry Systems – For entry systems offerings see pages 619-620		
Standard Cable Entry Boots	4" Boots	5" Boots
One Hole:	204679A-4	48939A-4
Tools – for additional tool offerings see pages 620-623		
EASIA [®] Plus Automated Cable Prep Tool	CPTL7	
1-5/8" Connector Torque Wrench	244374	
DIN Connector Coupling Torque Wrench	244377	
N Connector Coupling Torque Wrench	244379	



1-5/8" Foam Dielectric, LDF Series – 50-ohm

LDF7-50A

Description	Type No.
Cable Ordering Information	
Standard Cable	
1-5/8" Standard Cable, Standard Jacket	LDF7-50A
Fire Retardant Cable	
1-5/8" Fire Retardant Jacket (CATVR)	LDF7RN-50A
Low VSWR and Specialized Cables	
1-5/8" Low VSWR, specify operating band	LDF7P-50A-(**)

** Insert suffix number from "Low VSWR Specifications" table, page 522.

Characteristics

Electrical	
Impedance, ohms	50 ± 1
Maximum Frequency, GHz	2.5
Velocity, percent	88
Peak Power Rating, kW	315
dc Resistance, ohms/1000 ft (1000 m)	
Inner	0.25 (0.83)
Outer	0.16 (0.52)
dc Breakdown, volts	11000
Jacket Spark, volts RMS	10000
Capacitance, pF/ft (m)	23.1 (75.8)
Inductance, μH/ft (m)	0.058 (0.190)
Mechanical	
Outer Conductor	Copper
Inner Conductor	Copper Tube
Diameter over Jacket, in (mm)	1.98 (50)
Diameter over Copper Outer Conductor, in (mm)	1.825 (46.3)
Diameter Inner Conductor, in (mm)	0.681 (17.3)
Nominal Inside Transverse Dimensions, cm	4.05
Minimum Bending Radius, in (mm)	20 (510)
Number of Bends, minimum (typical)	15 (50)
Bending Moment, lb-ft (N•m)	40 (54.2)
Cable Weight, lb/ft (kg/m)	0.82 (1.2)
Tensile Strength, lb (kg)	800 (363)
Flat Plate Crush Strength, lb/in (kg/mm)	120 (2.1)

Attenuation and Average Power

Frequency MHz	Attenuation dB/100 ft	Attenuation dB/100 m	Average Power, kW
0.5	0.014	0.044	247.0
1	0.019	0.063	175.0
1.5	0.024	0.077	142.0
2	0.027	0.089	123.0
10	0.062	0.202	54.3
20	0.088	0.289	38.1
30	0.109	0.356	30.9
50	0.142	0.465	23.6
88	0.191	0.627	17.5
100	0.205	0.671	16.4
108	0.213	0.699	15.7
150	0.254	0.834	13.2
174	0.276	0.904	12.2
200	0.297	0.976	11.3
300	0.372	1.22	9.01
400	0.437	1.43	7.67
450	0.467	1.53	7.18
500	0.496	1.63	6.76
512	0.503	1.65	6.67
600	0.550	1.81	6.09
700	0.602	1.97	5.57
800	0.650	2.13	5.15
824	0.662	2.17	5.06
894	0.694	2.28	4.83
960	0.724	2.38	4.63
1000	0.742	2.43	4.52
1250	0.848	2.78	3.95
1500	0.947	3.11	3.54
1700	1.02	3.35	3.28
2000	1.13	3.71	2.96
2300	1.23	4.05	2.72
2500	1.30	4.27	2.58

Standard Conditions:

For Attenuation, VSWR 1.0, ambient temperature 20°C (68°F), atmospheric pressure, dry air.

For Average Power, VSWR 1.0, inner temperature 100°C (212°F), ambient temperature 40°C (104°F), atmospheric pressure, dry air, no solar loading.

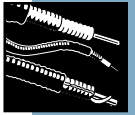

Connectors

Interface	Description	Type Number	Inner Contact Attachment	Outer Contact Attachment	Plating Code	Max. Length in (mm)	Max. Dia. in (mm)
N Male	OnePiece	L7PNM-RPC	Captivated	Self-Flare	SS	4.4 (112)	2.47 (62.7)
N Female	OnePiece	L7PNF-RPC	Captivated	Self-Flare	SG	4.5 (114)	2.47 (62.7)
N Female	RingFlare	L7PNF-RC	Captivated	Self-Flare	SG	4.2 (107)	2.36 (59.9)
7-16 DIN Male	OnePiece	L7PDM-RPC	Captivated	Self-Flare	SS	4.2 (107)	2.46 (62.5)
7-16 DIN Female	OnePiece	L7PDF-RPC	Captivated	Self-Flare	SS	4.1 (104)	2.45 (62.2)
7-16 DIN Female	RingFlare	L7PDF-RC	Captivated	Self-Flare	SS	3.4 (86)	2.36 (59.9)
7/8\" EIA Flange	-	L47S	Tab Flare	Self-Flare	BB	5.1 (130)	2.25 (57)
1-5/8\" EIA Flange	-	L47R	Tab Flare	Self-Flare	BB	5.1 (130)	3.5 (89)
F Flange Flange Male	-	L47F	Tab Flare	Self-Flare	BB	5.9 (150)	2.25 (57)
F Flange Flange Female	-	201942	Tab Flare	Self-Flare	BB	5.5 (140)	2.25 (57)
Splice	-	L47Z	Tab Flare	Self-Flare	BB	5.1 (130)	2.9 (74)

Plating Codes: BB - Brass Body and Pin, SG - Silver Plated Body and Gold Plated Pin, SS - Silver Plated Body and Pin

Connector Accessories – See page 624

Factory Attached Connectors – For factory made cable assemblies and jumper cables, see pages 584-587.

Standard VSWR Specifications

Frequency Band, GHz	Type Number	Assembly VSWR, Maximum (R.L., dB)				
		1-25 ft (0.3-8 m)	25-100 ft (8-30 m)	100-200 ft (30-60 m)	200-500 ft (60-150 m)	Above 500 ft (150 m)
0.806-0.960	LDF7-50A	1.10 (26.4)*	1.10 (26.4)*	1.12 (24.97)*	1.13 (24.3)*	1.13 (24.3)**
and 1.7-2.0	LDF7RN-50A	1.10 (26.4)*	1.10 (26.4)*	1.12 (24.97)*	1.13 (24.3)*	1.13 (24.3)**

* Expected typical values based on guaranteed 1.13 VSWR for bulk cable and Type N or DIN straight connectors. If guaranteed values are required, contact Andrew.
 ** 1.13 VSWR guaranteed for bulk standard cable lengths 500 ft and above.



Low VSWR Specifications, Type LDF7P-50A-()

Frequency Band, GHz	Type Number	Using Connector Type*	Assembly VSWR, Maximum (R.L., dB)				
			1-25 ft (0.3-8 m)	25-100 ft (8-30 m)	100-200 ft (30-60 m)	200-500 ft (60-150 m)	Above 500 ft (150 m)
0.780-0.960	LDF7P-50A-13A	N	1.07 (29.4)	1.07 (29.4)	1.08 (28.3)	1.10 (26.4)	1.12 (24.9)
		7-16 DIN Male	1.07 (29.4)	1.07 (29.4)	1.08 (28.3)	1.10 (26.4)	1.12 (24.9)
		7-16 DIN Female	1.08 (28.3)	1.08 (28.3)	1.10 (26.4)	1.12 (24.9)	1.12 (24.9)
0.806-0.960	LDF7P-50A-40	N	1.06 (30.7)	1.07 (29.4)	1.08 (28.3)	1.09 (27.3)	1.10 (26.4)
		7-16 DIN	1.06 (30.7)	1.07 (29.4)	1.08 (28.3)	1.09 (27.3)	1.10 (26.4)
0.800-0.960 and 1.85-1.99	LDF7P-50A-17A	N	1.09 (27.3)	1.09 (27.3)	1.10 (26.4)	1.12 (24.9)	1.12 (24.9)
		7-16 DIN	1.09 (27.3)	1.09 (27.3)	1.10 (26.4)	1.12 (24.9)	1.12 (24.9)
0.806-0.960 and 1.7-2.3	LDF7P-50A-42	N	1.10 (26.4)	1.10 (26.4)	1.10 (26.4)	1.10 (26.4)	1.10 (26.4)
		7-16 DIN	1.10 (26.4)	1.10 (26.4)	1.10 (26.4)	1.10 (26.4)	1.10 (26.4)
1.427-1.535	LDF7P-50A-4A	N	1.06 (30.7)	1.08 (28.3)	1.10 (26.4)	1.12 (24.9)	1.15 (23.1)
		7-16 DIN Male	1.06 (30.7)	1.08 (28.3)	1.10 (26.4)	1.12 (24.9)	1.15 (23.1)
		N Female Bulkhead	1.10 (26.4)	1.12 (24.9)	1.15 (23.1)	1.18 (21.6)	1.20 (20.8)
		7/8" EIA	1.06 (30.7)	1.08 (28.3)	1.10 (26.4)	1.12 (24.9)	1.15 (23.1)
		"F" Flange Female	1.10 (26.4)	1.18 (21.6)	1.20 (20.8)	1.22 (20.1)	1.25 (19.1)
		7-16 DIN Female	1.10 (26.4)	1.12 (24.9)	1.15 (23.1)	1.18 (21.6)	1.20 (20.8)
		LC Female	1.10 (26.4)	1.12 (24.9)	1.18 (21.6)	1.20 (20.8)	1.22 (20.1)
		1-5/8" EIA	1.10 (26.4)	1.15 (23.1)	1.18 (21.6)	1.20 (20.8)	1.22 (20.1)
		"F" Flange Male	1.20 (20.8)	1.22 (20.1)	1.25 (19.1)	1.28 (18.2)	1.30 (17.7)
		LC Male	1.30 (17.7)	1.32 (17.2)	1.35 (16.5)	1.38 (15.9)	1.40 (15.6)
		1.7-2.3	LDF7P-50A-41	N	1.10 (26.4)	1.10 (26.4)	1.10 (26.4)
7-16 DIN	1.10 (26.4)			1.10 (26.4)	1.10 (26.4)	1.10 (26.4)	1.10 (26.4)
1.7-2.11	LDF7P-50A-6A	N	1.08 (28.3)	1.10 (26.4)	1.12 (24.9)	1.15 (23.1)	1.15 (23.1)
		7-16 DIN Male	1.08 (28.3)	1.10 (26.4)	1.12 (24.9)	1.15 (23.1)	1.20 (20.8)
		N Female Bulkhead	1.10 (26.4)	1.12 (24.9)	1.15 (23.1)	1.20 (20.8)	1.25 (19.1)
		7/8" EIA	1.08 (28.3)	1.10 (26.4)	1.12 (24.9)	1.15 (23.1)	1.15 (23.1)
		"F" Flange Female	1.30 (17.7)	1.32 (17.2)	1.35 (16.5)	1.38 (15.9)	1.40 (15.6)
		7-16 DIN Female	1.10 (26.4)	1.12 (24.9)	1.15 (23.1)	1.20 (20.8)	1.25 (19.1)
		LC Female	1.20 (20.8)	1.22 (20.1)	1.25 (19.1)	1.28 (18.2)	1.30 (17.7)
		1-5/8" EIA	1.10 (26.4)	1.12 (24.9)	1.15 (23.1)	1.20 (20.8)	1.25 (19.1)
		"F" Flange Male	1.12 (24.9)	1.15 (23.1)	1.18 (21.6)	1.20 (20.8)	1.25 (19.1)
1.85-2.11	LDF7P-50A-7A	N	1.08 (28.3)	1.10 (26.4)	1.12 (24.9)	1.15 (23.1)	1.15 (23.1)
		7-16 DIN Male	1.08 (28.3)	1.10 (26.4)	1.12 (24.9)	1.15 (23.1)	1.20 (20.8)
		N Female Bulkhead	1.10 (26.4)	1.12 (24.9)	1.15 (23.1)	1.20 (20.8)	1.25 (19.1)
		7/8" EIA	1.08 (28.3)	1.10 (26.4)	1.12 (24.9)	1.15 (23.1)	1.15 (23.1)
		"F" Flange Female	1.20 (20.8)	1.22 (20.1)	1.25 (19.1)	1.28 (18.2)	1.30 (17.7)
		7-16 DIN Female	1.10 (26.4)	1.12 (24.9)	1.15 (23.1)	1.20 (20.8)	1.25 (19.1)
		LC Female	1.30 (17.7)	1.32 (17.2)	1.35 (16.5)	1.38 (15.9)	1.40 (15.6)
		1-5/8" EIA	1.10 (26.4)	1.12 (24.9)	1.15 (23.1)	1.20 (20.8)	1.25 (19.1)
		"F" Flange Male	1.12 (24.9)	1.15 (23.1)	1.18 (21.6)	1.20 (20.8)	1.25 (19.1)
		1.9-2.3	LDF7P-50A-8A	N	1.08 (28.3)	1.10 (26.4)	1.12 (24.9)
7-16 DIN Male	1.10 (26.4)			1.15 (23.1)	1.20 (20.8)	1.25 (19.1)	1.25 (19.1)
N Female Bulkhead	1.25 (19.1)			1.28 (18.2)	1.30 (17.7)	1.32 (17.2)	1.35 (16.5)
7/8" EIA	1.08 (28.3)			1.10 (26.4)	1.12 (24.9)	1.15 (23.1)	1.15 (23.1)
"F" Flange Female	1.30 (17.7)			1.35 (16.5)	1.40 (15.6)	1.45 (14.8)	1.50 (14.0)
7-16 DIN Female	1.20 (20.8)			1.25 (19.1)	1.28 (18.2)	1.30 (17.7)	1.35 (16.5)
LC Female	1.25 (19.1)			1.30 (17.7)	1.35 (16.5)	1.40 (15.6)	1.40 (15.6)
1-5/8" EIA	1.20 (20.8)			1.25 (19.1)	1.28 (18.2)	1.30 (17.7)	1.35 (16.5)
"F" Flange Male	1.15 (23.1)			1.20 (20.8)	1.25 (19.1)	1.28 (18.2)	1.30 (17.7)
2.1-2.2	LDF7P-50A-9A			N	1.08 (28.3)	1.10 (26.4)	1.12 (24.9)
		7-16 DIN Male	1.10 (26.4)	1.15 (23.1)	1.20 (20.8)	1.25 (19.1)	1.25 (19.1)
		N Female Bulkhead	1.25 (19.1)	1.28 (18.2)	1.30 (17.7)	1.32 (17.2)	1.35 (16.5)
		7/8" EIA	1.08 (28.3)	1.10 (26.4)	1.12 (24.9)	1.15 (23.1)	1.15 (23.1)
		"F" Flange Female	1.30 (17.7)	1.35 (16.5)	1.40 (15.6)	1.45 (14.8)	1.50 (14.0)
		7-16 DIN Female	1.20 (20.8)	1.25 (19.1)	1.28 (18.2)	1.30 (17.7)	1.35 (16.5)
		LC Female	1.25 (19.1)	1.30 (17.7)	1.35 (16.5)	1.40 (15.6)	1.40 (15.6)
		1-5/8" EIA	1.15 (23.1)	1.20 (20.8)	1.25 (19.1)	1.28 (18.2)	1.30 (17.7)
		"F" Flange Male	1.20 (20.8)	1.25 (19.1)	1.28 (18.2)	1.30 (17.7)	1.35 (16.5)
0.01-2.5	LDF7P-50A-10A	N	1.10 (26.4)	1.20 (20.8)	1.30 (17.7)	1.55 (13.3)	1.65 (12.2)
		7-16 DIN Male	1.10 (26.4)	1.20 (20.8)	1.30 (17.7)	1.60 (12.7)	1.65 (12.2)
		7/8" EIA	1.10 (26.4)	1.20 (20.8)	1.30 (17.7)	1.55 (13.3)	1.65 (12.2)
		7-16 DIN Female	1.15 (23.1)	1.25 (19.1)	1.35 (16.5)	1.65 (12.2)	1.75 (11.3)
		1-5/8" EIA	1.15 (23.1)	1.25 (19.1)	1.35 (16.5)	1.65 (12.2)	1.75 (11.3)
		"F" Flange Male	1.10 (26.4)	1.20 (20.8)	1.30 (17.7)	1.55 (13.3)	1.65 (12.2)

* Connectors ordered separately

VSWR values apply to straight connectors only, are guaranteed for factory fit assemblies, and are typical for field cut lengths. If two different connector interfaces are selected, the higher VSWR value is guaranteed.



Accessories

Description	Type No.
Hangers – For more hangers, adapters and mounting hardware see pages 599-607	
Standard Hangers Kit of 10. Standard tower configuration spacing is 3-4 feet (1-1.2 m). For different spacing recommendations, refer to Cable Hanger Spacing, page 593-598	42396A-2
Hardware Kit of 10. 3/8" bolts, lockwashers, nuts	
3/4" (19 mm) long	31769-5
1" (25 mm) long	31769-1
Snap-in Hangers Kit of 10. For prepunched 3/4" (19 mm) holes on tower member or adapters, Recommended maximum spacing is 3-ft. For different spacing recommendations, refer to Cable Hanger Spacing, page 593-598	206706-4
Click-On Hangers Kit of 10. Recommended maximum spacing is 3-ft	L7CLICK
Mounting Hardware see page 605	
Kwik-Clamps Kit of 10. See page 607 for hanger options	
Support/Hoisting Grip . Use at 200-ft (60m) intervals.	
Grip with one clamp	L7SGRIP
Support clamp kit of 10	L7SGRIP-7IK
Standard Hoisting Grip	24312

Grounding and Surge Protection – for additional grounding kits and our surge protection offerings, see pages 609-616

SureGround Grounding Kit with standard weatherproofing	
Factory attached one-hole lug, 600 mm (24") lead	SGL7-06B1
Factory attached two-hole lug, 600 mm (24") lead	SGL7-06B2
Field attached two-hole lug, 1500 mm (59") lead	SGL7-15B4
SureGround Plus Grounding Kit with weatherproofing boot	
Factory attached one-hole lug, 600 mm (24") lead	SGPL7-06B1
Factory attached two-hole lug, 600 mm (24") lead	SGPL7-06B2
Field attached two-hole lug, 1500 mm (59") lead	SGPL7-15B4
Arrestor Plus Integrated T-Series Arrestors – see page 614	
Bulkhead N Female	APTL7-BNF-(*)
Bulkhead 7-16 DIN Female	APTL7-BDF-(*)

* Frequency band. See page 614.

Description	Type No.	
Weatherproofing – for additional weatherproofing information see pages 617-618		
WeatherShield™ Connector Protection Housing		
LDF7 to LDF4	WS-L7L4	
LDF7 to FSJ4	WS-L7F4	
Cold Shrink Weatherproofing Kit		
1-5/8" Coax to 1-5/8" Coax N Connectors	241474-6	
1-5/8" Coax to 1/4" Coax	241475-11	
1-5/8" Coax to 3/8" or 1/2" Coax	241475-5A	
1-5/8" to APTL7 Arrestors	241474-6	
Connector/Splice Weatherproofing Kit	221213	
Entry Systems – For entry systems offerings see pages 619-620		
Standard Cable Entry Boots	4" Boots	5" Boots
One Hole:	204679A-4	48939A-4
Tools – for additional tool offerings see pages 620-623		
EASIAx® Plus Automated Cable Prep Tool	CPTL7	
1-5/8" Connector Torque Wrench	244374	
DIN Connector Coupling Torque Wrench	244377	
N Connector Coupling Torque Wrench	244379	



2-1/4" Foam Dielectric, LDF Series – 50-ohm

LDF12-50

Description	Type No.
Cable Ordering Information	
Standard Cable	
2-1/4" Standard Cable, Standard Jacket	LDF12-50
Fire Retardant Cable	
2-1/4" Fire Retardant Jacket (CATVR)	LDF12RN-50
Low VSWR Cable	
2-1/4" Low VSWR, specify operating band	LDF12P-50-(**)

** Insert suffix number from "Low VSWR Specifications" table, page 525.

Characteristics

Electrical	
Impedance, ohms	50 ± 1
Maximum Frequency, GHz	2.2
Velocity, percent	88
Peak Power Rating, kW	425
dc Resistance, ohms/1000 ft (1000 m)	
Inner	0.21 (0.68)
Outer	0.09 (0.29)
dc Breakdown, volts	13000
Jacket Spark, volts RMS	10000
Capacitance, pF/ft (m)	22.7 (74.6)
Inductance, μH/ft (m)	0.058 (0.189)
Mechanical	
Outer Conductor	Copper
Inner Conductor	Copper Tube
Diameter over Jacket, in (mm)	2.35 (60)
Diameter over Copper Outer Conductor, in (mm)	2.2 (55.9)
Diameter Inner Conductor, in (mm)	0.835 (21.2)
Minimum Bending Radius, in (mm)	24 (610)
One-Time Bending Radius, in (mm)	9.5 (240)
Number of Bends, minimum (typical)	15 (50)
Bending Moment, lb-ft (N•m)	70 (95)
Cable Weight, lb/ft (kg/m)	1.22 (1.82)
Tensile Strength, lb (kg)	1500 (681)
Flat Plate Crush Strength, lb/in (kg/mm)	150 (2.7)

Attenuation and Average Power

Frequency MHz	Attenuation dB/100 ft	Attenuation dB/100 m	Average Power, kW
0.5	0.011	0.037	321.0
1	0.016	0.052	227.0
1.5	0.020	0.064	185.0
2	0.023	0.074	160.0
10	0.052	0.169	70.3
20	0.074	0.242	49.2
30	0.091	0.299	39.8
50	0.119	0.391	30.4
88	0.161	0.529	22.5
100	0.173	0.566	21.0
108	0.180	0.591	20.1
150	0.215	0.707	16.8
174	0.234	0.767	15.5
200	0.253	0.829	14.4
300	0.317	1.04	11.4
400	0.374	1.23	9.7
450	0.400	1.31	9.06
500	0.426	1.40	8.52
512	0.432	1.42	8.40
600	0.474	1.55	7.66
700	0.519	1.70	6.99
800	0.562	1.84	6.45
824	0.572	1.88	6.34
894	0.601	1.97	6.03
960	0.628	2.06	5.78
1000	0.644	2.11	5.64
1250	0.739	2.42	4.91
1500	0.828	2.72	4.38
1700	0.896	2.94	4.05
1800	0.929	3.05	3.91
2000	0.994	3.26	3.65
2100	1.03	3.37	3.54
2200	1.06	3.47	3.43

Standard Conditions:

For Attenuation. VSWR 1.0, ambient temperature 20°C (68°F).

For Average Power. VSWR 1.0, ambient temperature 40°C (104°F), inner conductor temperature 100°C (212°F); no solar loading.



7-16 DIN Female
L12PDF



3-1/8" EIA Flange
L12FB-302

Connectors

Interface	Description	Type Number	Inner Contact Attachment	Outer Contact Attachment	Plating Code	Max. Length in (mm)	Max. Dia. in (mm)
N Female	–	L12PNF	Self-Tapping	Self-Flare	SS	5.1 (130)	2.75 (69.9)
7-16 DIN Male	–	L12PDM	Self-Tapping	Self-Flare	SS	5.8 (147)	2.75 (69.9)
7-16 DIN Female	–	L12PDF	Self-Tapping	Self-Flare	SS	5.5 (139)	2.75 (69.9)
3 1/8" EIA Flange	Gas Pass	L12FP-302	Self-Tapping	Self-Flare	BS	7.6 (192)	5.19 (131.8)
3 1/8" EIA Flange	Gas Barrier	L12FB-302	Self-Tapping	Self-Flare	BS	7.6 (192)	5.19 (131.8)
Splice	–	L12Z	Self-Tapping	Self-Flare	BB	5.8 (147)	3.00 (76.2)

Plating Codes: BB - Brass Body and Pin, BS - Brass Body and Silver Plated Pin, SG - Silver Plated Body and Gold Plated Pin, SS - Silver Plated Body and Pin

Connector Accessories – See page 624

Factory Attached Connectors – For factory made cable assemblies and jumper cables, see pages 584-587.

Low VSWR Specifications, Type LDF12P-50A-()

Frequency Band, GHz	Type Number	Using Connector Type*	Assembly VSWR, Maximum (R.L., dB)				
			1-25 ft (0.3-8 m)	25-100 ft (8-30 m)	100-200 ft (30-60 m)	200-500 ft (60-150 m)	Above 500 ft (150 m)
0.806-0.960	LDF12P-50-1	N Female	1.08 (28.3)	1.09 (27.3)	1.10 (26.4)	1.10 (26.4)	1.10 (26.4)
		7-16 DIN Female	1.08 (28.3)	1.09 (27.3)	1.10 (26.4)	1.10 (26.4)	1.10 (26.4)
0.806-0.96 and 1.7-2.2	LDF12P-50-2	N Female	1.13 (24.2)	1.14 (23.7)	1.15 (23.1)	1.15 (23.1)	1.15 (23.1)
		7-16 DIN Female	1.13 (24.2)	1.14 (23.7)	1.15 (23.1)	1.15 (23.1)	1.15 (23.1)
1.7-1.9	LDF12P-50-3	N Female	1.13 (24.2)	1.13 (24.2)	1.14 (23.7)	1.14 (23.7)	1.15 (23.1)
		7-16 DIN Female	1.13 (24.2)	1.13 (24.2)	1.14 (23.7)	1.14 (23.7)	1.15 (23.1)

* Connectors ordered separately

VSWR values apply to straight connectors only, are guaranteed for factory fit assemblies, and are typical for field cut lengths. If two different connector interfaces are selected, the higher VSWR value is guaranteed.



Accessories

Description	Type No.
Hangers – For more hangers, adapters and mounting hardware see pages 599-607	
Standard Hangers Kit of 10. Standard tower configuration spacing is 3-4 feet (1-1.2m). For different spacing recommendations, refer to Cable Hanger Spacing, page 593-598	42396A-4
Hardware Kit of 10. 3/8" bolts, lockwashers, nuts	
3/4" (19mm) long	31769-5
1" (25mm) long	31769-1
Snap-in Hangers Kit of 10. For prepunched 3/4" (19mm) holes on tower member or adapters. Standard tower configuration spacing is 3-4 feet. (1-1.2m). For different spacing recommendations, refer to Cable Hanger Spacing, page 593-598	206706-5
Support/Hoisting Grip. Use at 200-ft (60m) intervals.	
Grip with one clamp	L12SGRIP
Support clamp kit of 10	L12SGRIP-12IK
Standard Hoisting Grip	31535

Grounding and Surge Protection – for additional grounding kits and our surge protection offerings, see pages 609-616

SureGround Grounding Kit with standard weatherproofing	
Factory attached one-hole lug, 600 mm (24") lead	SGL12-06B1
Factory attached two-hole lug, 600 mm (24") lead	SGL12-06B2
Field attached two-hole lug, 1500 mm (59") lead	SGL12-15B4
SureGround Plus Grounding Kit with weatherproofing boot	
Factory attached one-hole lug, 600 mm (24") lead	SGPL12-06B1
Factory attached two-hole lug, 600 mm (24") lead	SGPL12-06B2
Field attached two-hole lug, 1500 mm (59") lead	SGPL12-15B4

Description	Type No.
Weatherproofing – for additional weatherproofing information see pages 617-618	
Cold Shrink Weatherproofing Kit	
2-1/4" Coax - to 3/8" or 1/2" Coax	241475-8
Connector/Splice Weatherproofing Kit	221213
Entry Systems – For entry systems offerings see pages 619-620	
Standard Cable Entry Boots	
4" Boots – One Hole:	204679A-8
5" Boots – One Hole:	48939A-9
Tools – for additional tool offerings see pages 620-623	
LDF12 Connector Torque Wrench	244373
DIN Connector Coupling Torque Wrench	244377
N Connector Coupling Torque Wrench	244379

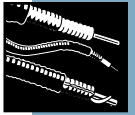

1/4" Air Dielectric, Plenum Rated (CATVP), HS Series – 50-ohm



HS1RP-50A

Description	Type No.
Cable Ordering Information	
Plenum Cable	
1/4" Fire Retardant Cable, 1/4" Fire Retardant Jacket (CATVP)	HS1RP-50A
Characteristics	
Electrical	
Impedance, ohms	50 ± 2
Maximum Frequency, GHz	10
Velocity, percent	84
Peak Power Rating, kW	6.4
dc Resistance, ohms/1000 ft (1000 m)	
Inner	2.1 (6.8)
Outer	2.0 (6.5)
dc Breakdown, volts	1600
Jacket Spark, volts RMS	4000
Capacitance, pF/ft (m)	23.8 (78.0)
Inductance, µH/ft (m)	0.061 (0.202)
Mechanical	
Outer Conductor	Copper
Inner Conductor	Copper
Diameter over Jacket, in (mm)	0.29 (7.4)
Diameter over Copper Outer Conductor, in (mm)	0.25 (6.4)
Minimum Bending Radius, in (mm)	1 (25)
Number of Bends, minimum (typical)	15 (20)
Bending Moment, lb-ft (N•m)	1.9 (2.6)
Cable Weight, lb/ft (kg/m)	0.063 (45)
Tensile Strength, lb (kg)	100 (45)
Flat Plate Crush Strength, lb/in (kg/mm)	80 (1.4)

Attenuation and Average Power

Frequency MHz	Attenuation dB/100 ft	Attenuation dB/100 m	Average Power, kW
0.5	0.120	0.395	6.40
1	0.170	0.559	6.40
1.5	0.209	0.685	6.40
2	0.241	0.792	6.10
10	0.541	1.78	2.72
20	0.767	2.52	1.92
30	0.941	3.09	1.56
50	1.22	4.00	1.21
88	1.62	5.33	0.907
100	1.73	5.69	0.850
108	1.80	5.91	0.817
150	2.13	6.99	0.691
174	2.30	7.54	0.640
200	2.47	8.10	0.596
300	3.04	9.98	0.484
400	3.53	11.6	0.417
450	3.75	12.3	0.393
500	3.96	13.0	0.372
512	4.01	13.2	0.367
600	4.36	14.3	0.338
700	4.72	15.5	0.312
800	5.07	16.6	0.291
824	5.14	16.9	0.286
894	5.37	17.6	0.274
960	5.58	18.3	0.264
1000	5.70	18.7	0.259
1250	6.41	21.0	0.230
1500	7.06	23.2	0.209
1700	7.55	24.8	0.195
1800	7.79	25.5	0.189
2000	8.24	27.0	0.179
2100	8.46	27.8	0.174
2200	8.68	28.5	0.170
2300	8.89	29.2	0.166
3000	10.3	33.7	0.144
3400	11.0	36.1	0.134
4000	12.0	39.5	0.123
5000	13.6	44.7	0.108
6000	15.1	49.5	0.098
8000	17.7	58.2	0.083
10000	20.2	66.2	0.073

Standard Conditions:

For Attenuation. VSWR 1.0, ambient temperature 20°C (68°F).

For Average Power. VSWR 1.0, ambient temperature 40°C (104°F), inner conductor temperature 100°C (212°F); no solar loading.



Connectors

Interface	Description	Type Number	Inner Contact Attachment	Outer Contact Attachment	Plating Code	Max. Length in (mm)	Max. Dia. in (mm)
N Male	Hex Head	F1PNMV2-H	Solder	Self-Clamping	SG	2.1 (53)	0.95 (24.1)
N Male	High Freq.	F1PNM-HF	Solder	Tab Flare	SG	1.3 (33)	0.81 (20.5)
N Male	Right Angle Hex Head	F1PNR-HC	Captivated	Self-Clamping	SG	1.7/1.3 (43/33)	0.95 (24.1)
N Female		F1PNF	Solder	Self-Flare	SG	2.2 (55.2)	0.58 (14.8)
N Female	Bulkhead	F1PNF-BH	Solder	Self-Clamping	SG	2.3 (58)	0.94 (23.9)
BNC Male	-	F1PBM	Solder	Self-Clamping	SS	2.0 (50)	0.69 (17.5)
UHF Male	-	41SP	Solder	Solder	BB	1.8 (46)	0.77 (19.6)
UHF Female	-	41U	Solder	Solder	BS	2.1 (53)	0.77 (19.6)
SMA Male	Up to 6 GHz	F1PSM	Solder	Self-Clamping	PG	1.7 (43)	0.49 (12.5)
SMA Male	Right Angle	F1PSR	Solder	Self-Clamping	PG	1.6/0.75 (41/19)	0.50 (12.7)
SMA Female	Up to 6 GHz, Bulkhead	F1PSF	Solder	Self-Clamping	PG	1.7 (43)	0.49 (12.5)
SMA Male	Up to 18 GHz	41EWS	Solder	Tab Flare	G	0.94 (23.9)	0.40 (10.2)
SMA Female	Up to 18 GHz	41ENS	Solder	Tab Flare	G	1.00 (25.4)	0.40 (10.2)
TNC Male	11 GHz and Below	F1PTM	Solder	Self-Clamping	SG	1.68 (43)	0.57 (14.5)
TNC Female	Bulkhead	41AENT	Captivated	Tab Flare	NG	1.5 (38)	0.70 (17.8)
TNC Male	Hi Freq, Above 11 GHz	F1PTM-HF	Captivated	Tab Flare	NG	1.9 (48.8)	0.70 (17.8)
Mini-UHF Male	-	F1MU	Captivated	Crimp	NS	1.53 (39)	0.47 (11.9)
7-16 DIN Male	-	F1PDM	Solder	Self-Clamping	SS	1.82 (46.3)	1.25 (31.75)
7-16 DIN Female	-	F1PDF	Solder	Self-Clamping	SS	1.85 (47)	0.551 (14)
7-16 DIN Female	Panel Mount	F1PDF-PM	Solder	Self-Clamping	SS	1.85 (47)	1.26 (32)
7-16 DIN Female	Bulkhead	F1PDF-BH	Solder	Self Clamping	SS	1.85 (47)	1.62 (41)

* Stainless steel body Plating Codes: BB - Brass Body and Pin, BS - Brass Body and Silver Plated Pin, NG - Nickel Plated Body and Gold Plated Pin, NS- Nickel Plated Body and Silver Plated Pin, PG - Passivated Body and Gold Plated Pin, SG - Silver Plated Body and Gold Plated Pin, SS - Silver Plated Body and Pin, G - Stainless Steel Body and Gold Plated Pin.

Connector Accessories – See page 624

Factory Attached Connectors – For factory made cable assemblies and jumper cables, see pages 584-587.

Accessories

Description	Type No.
Hangers – For more hangers, adapters and mounting hardware see pages 599-607	
Insulated Hanger , single. Recommended maximum spacing is 2.5 ft (0.76 m). For different spacing recommendations, refer to Cable Hanger Spacing, page 593-598	11662-3
Angle Adapter , for insulated hanger	40430-1
Nylon Cable Tie Kit of 50. Indoor use, Recommended maximum spacing is 1.5 ft (0.5 m)	40417
Nylon Cable Tie Kit in plastic box. 100 each 4, 5.5 and 7.5 inch ties. Indoor use, Recommended maximum spacing is 1.5 ft (0.5 m)	CT-K350
Velcro Cable Ties , Black, 8 inch. Indoor Use	
Kit of 10	VCT8-10
Kit of 50	VCT8-50
Kit of 100	VCT8-100

Description	Type No.
Grounding and Surge Protection – for additional grounding kits and our surge protection offerings, see pages 609-616	
Standard Grounding Kit	
Factory attached one-hole lug, 24" lead	223158
Factory attached two-hole lug, 24" lead	223158-2
Field attached one-hole lug, 36" lead	223158-3
Weatherproofing – for additional weatherproofing information see pages 617-618	
Cold Shrink Weatherproofing Kit	
5/8" Coax to 1/4" Coax	241475-13
7/8" Coax to 1/4" Coax	241475-12
1-1/4" or 1-5/8" Coax to 1/4" Coax	241475-11
1/4" to 1-1/2" Omni/Panel base Type N or DIN	241548-10
1/4" to 2" Omni/Panel base Type N or DIN	241548-11
Connector/Splice Weatherproofing Kit	221213
Entry Systems – For entry systems offerings see pages 619-620	
Standard Cable Entry Boots	
4" Boots – Three Hole:	204679A-17
Tools – for additional tool offerings see pages 620-623	
EASIAx® Cutting Tool FSJ1/FSJ4/HS1	207865
N Connector Coupling Torque Wrench	244379

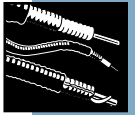

1/4" High Power,
High Temperature,
Air Dielectric,
HST Series – 50-ohm



HELIAX® Coaxial Cables

HST1-50

Description	Type No.
Cable Ordering Information	
High Power, High Temperature Cable	
1/4" Cable	HST1-50
Characteristics	
Electrical	
Impedance, ohms	50 ± 2
Maximum Frequency, GHz	18
Velocity, percent	82
Peak Power Rating, kW	6.4
dc Resistance, ohms/1000 ft (1000 m)	
Inner	2.05 (6.71)
Outer	2.0 (6.5)
dc Breakdown, volts	1600
Jacket Spark, volts RMS	4000
Capacitance, pF/ft (m)	25.1 (82.4)
Inductance, µH/ft (m)	0.061 (0.202)
Mechanical	
Outer Conductor	Copper
Inner Conductor	Silver Plated Copper
Diameter over Jacket, in (mm)	0.29 (7.4)
Diameter over Copper Outer Conductor, in (mm)	0.25 (6.4)
Minimum Bending Radius, in (mm)	1 (25)
Number of Bends, minimum (typical)	15 (20)
Bending Moment, lb-ft (N·m)	1.7 (2.3)
Cable Weight, lb/ft (kg/m)	0.057 (0.085)
Tensile Strength, lb (kg)	100 (45)
Flat Plate Crush Strength, lb/in (kg/mm)	80 (1.4)

Attenuation and Average Power

Frequency MHz	Attenuation dB/100 ft	Attenuation dB/100 m	Average Power, kW
0.5	0.116	0.382	6.40
1	0.165	0.540	6.40
1.5	0.202	0.662	6.40
2	0.233	0.764	6.40
10	0.523	1.72	6.26
20	0.742	2.43	4.41
30	0.911	2.99	3.60
50	1.18	3.87	2.77
88	1.57	5.16	2.08
100	1.68	5.51	1.95
108	1.75	5.73	1.87
150	2.07	6.78	1.58
174	2.23	7.32	1.47
200	2.40	7.87	1.37
300	2.96	9.70	1.11
400	3.43	11.3	0.954
450	3.65	12.0	0.897
500	3.86	12.7	0.849
512	3.91	12.8	0.838
600	4.25	13.9	0.771
700	4.61	15.1	0.711
800	4.95	16.2	0.662
824	5.02	16.5	0.652
894	5.25	17.2	0.624
960	5.45	17.9	0.601
1000	5.57	18.3	0.588
1250	6.28	20.6	0.522
1500	6.92	22.7	0.473
1700	7.41	24.3	0.442
1800	7.64	25.1	0.429
2000	8.10	26.6	0.405
2100	8.31	27.3	0.394
2200	8.53	28.0	0.384
2300	8.74	28.7	0.375
3000	10.1	33.2	0.324
3400	10.9	35.6	0.302
4000	11.9	39.0	0.276
5000	13.5	44.3	0.243
6000	15.0	49.1	0.219
8000	17.7	58.0	0.185
10000	20.2	66.2	0.163
12000	22.5	73.8	0.146
14000	24.7	81.0	0.133
16000	26.8	87.8	0.123
18000	28.8	94.4	0.114

Standard Conditions:

For Attenuation. VSWR 1.0, ambient temperature 20°C (68°F).

For Average Power. VSWR 1.0, ambient temperature 40°C (104°F), inner conductor temperature 200°C (392°F); no solar loading.



Connectors

Interface	Description	Type Number	Inner Contact Attachment	Outer Contact Attachment	Plating Code	Max. Length in (mm)	Max. Dia. in (mm)
N Male	Hex Head	F1PNMV2-H	Solder	Self-Clamping	SG	2.1 (53)	0.95 (24.1)
N Male	High Freq.	F1PNM-HF	Solder	Tab Flare	SG	1.3 (33)	0.81 (20.5)
N Male	Right Angle Hex Head	F1PNR-HC	Captivated	Self-Clamping	SG	1.7/1.3 (43/33)	0.95 (24.1)
N Female		F1PNF	Solder	Self-Flare	SG	2.2 (55.2)	0.58 (14.8)
N Female	Bulkhead	F1PNF-BH	Solder	Self-Clamping	SG	2.3 (58)	0.94 (23.9)
BNC Male	-	F1PBM	Solder	Self-Clamping	SS	2.0 (50)	0.69 (17.5)
UHF Male	-	41SP	Solder	Solder	BB	1.8 (46)	0.77 (19.6)
UHF Female	-	41U	Solder	Solder	BS	2.1 (53)	0.77 (19.6)
SMA Male	Up to 6 GHz	F1PSM	Solder	Self-Clamping	PG	1.7 (43)	0.49 (12.5)
SMA Male	Right Angle	F1PSR	Solder	Self-Clamping	PG	1.6/0.75 (41/19)	0.50 (12.7)
SMA Female	Up to 6 GHz, Bulkhead	F1PSF	Solder	Self-Clamping	PG	1.7 (43)	0.49 (12.5)
SMA Male	Up to 18 GHz	41EWS	Solder	Tab Flare	G	0.94 (23.9)	0.40 (10.2)
SMA Female	Up to 18 GHz	41ENS	Solder	Tab Flare	G	1.00 (25.4)	0.40 (10.2)
TNC Male	11 GHz and Below	F1PTM	Solder	Self-Clamping	SG	1.68 (43)	0.57 (14.5)
TNC Female	Bulkhead	41AENT	Captivated	Tab Flare	NG	1.5 (38)	0.70 (17.8)
TNC Male	Hi Freq, Above 11 GHz	F1PTM-HF	Captivated	Tab Flare	NG	1.9 (48.8)	0.70 (17.8)
Mini-UHF Male	-	F1MU	Captivated	Crimp	NS	1.53 (39)	0.47 (11.9)
7-16 DIN Male	-	F1PDM	Solder	Self-Clamping	SS	1.82 (46.3)	1.25 (31.75)
7-16 DIN Female	-	F1PDF	Solder	Self-Clamping	SS	1.85 (47)	0.551 (14)
7-16 DIN Female	Panel Mount	F1PDF-PM	Solder	Self-Clamping	SS	1.85 (47)	1.26 (32)
7-16 DIN Female	Bulkhead	F1PDF-BH	Solder	Self Clamping	SS	1.85 (47)	1.62 (41)

* Stainless steel body **Plating Codes:** BB - Brass Body and Pin, BS - Brass Body and Silver Plated Pin, NG - Nickel Plated Body and Gold Plated Pin, NS - Nickel Plated Body and Silver Plated Pin, PG - Passivated Body and Gold Plated Pin+A135, SG - Silver Plated Body and Gold Plated Pin, SS - Silver Plated Body and Pin, G - Stainless Steel Body and Gold Plated Pin.

Connector Accessories – See page 624

Factory Attached Connectors – For factory made cable assemblies and jumper cables, see pages 584-587.

Accessories

Description	Type No.
Hangers – For more hangers, adapters and mounting hardware see pages 599-607	
Insulated Hanger , single. Recommended maximum spacing is 2.5 ft (0.76 m). For different spacing recommendations, refer to Cable Hanger Spacing, page 593-598	11662-3
Angle Adapter , for insulated hanger	40430-1
Nylon Cable Tie Kit of 50, Indoor use, Recommended maximum spacing is 1.5 ft (0.5 m)	40417
Nylon Cable Tie Kit in plastic box. 100 each 4, 5.5 and 7.5 inch ties. Indoor use, Recommended maximum spacing is 1.5 ft (0.5 m)	CT-K350
Velcro Cable Ties , Black, 8 inch. Indoor Use	
Kit of 10	VCT8-10
Kit of 50	VCT8-50
Kit of 100	VCT8-100

Description	Type No.
Grounding and Surge Protection – for additional grounding kits and our surge protection offerings, see pages 609-616	
Standard Grounding Kit	
Factory attached one-hole lug, 24" lead	223158
Factory attached two-hole lug, 24" lead	223158-2
Field attached one-hole lug, 36" lead	223158-3
Weatherproofing – for additional weatherproofing information see pages 617-618	
Cold Shrink Weatherproofing Kit	
5/8" Coax to 1/4" Coax	241475-13
7/8" Coax to 1/4" Coax	241475-12
1-1/4" or 1-5/8" Coax to 1/4" Coax	241475-11
1/4" to 1-1/2" Omni/Panel base Type N or DIN	241548-10
1/4" to 2" Omni/Panel base Type N or DIN	241548-11
Connector/Splice Weatherproofing Kit	221213
Entry Systems – For entry systems offerings see pages 619-620	
Standard Cable Entry Boots	
4" Boots – Three Hole:	204679A-17
Tools – for additional tool offerings see pages 620-623	
EASIAx® Cutting Tool FSJ1/FSJ4/HS1/HST1	207865
N Connector Coupling Torque Wrench	244379



3/8" Air Dielectric, Plenum Rated (CATVP), HS Series – 50-ohm



HS2RP-50

Description	Type No.
Cable Ordering Information	
Plenum Cable	
3/8" Fire Retardant Cable	HS2RP-50
Characteristics	
Electrical	
Impedance, ohms	50 ± 1
Maximum Frequency, GHz	13.4
Velocity, percent	83
Peak Power Rating, kW	13.2
dc Resistance, ohms/1000 ft (1000 m)	
Inner	1.41 (4.64)
Outer	1.52 (4.99)
dc Breakdown, volts	2300
Jacket Spark, volts RMS	5000
Capacitance, pF/ft (m)	23.61 (77.47)
Inductance, µH/ft (m)	0.064 (0.208)
Mechanical	
Outer Conductor	Copper
Inner Conductor	Copper-Clad Aluminum
Diameter over Jacket, in (mm)	0.415 (10.5)
Diameter over Copper Outer Conductor, in (mm)	0.375 (9.5)
Minimum Bending Radius, in (mm)	1 (25)
Number of Bends, minimum	20 (50)
Bending Moment, lb-ft (N·m)	1.8 (2.45)
Cable Weight, lb/ft. (kg/m)	0.076 (0.113)
Tensile Strength, lb (kg)	210 (95)
Flat Plate Crush Strength, lb/in (kg/mm)	100 (1.8)

Attenuation and Average Power Ratings

Frequency MHz	Attenuation dB/100 ft	Attenuation dB/100 m	Average Power, kW
0.5	0.083	0.273	13.2
1	0.118	0.386	13.2
1.5	0.144	0.473	12.1
2	0.166	0.546	10.5
10	0.374	1.23	4.67
20	0.530	1.74	3.30
30	0.650	2.13	2.69
50	0.843	2.76	2.07
88	1.12	3.69	1.55
100	1.20	3.94	1.46
108	1.25	4.09	1.40
150	1.48	4.84	1.18
174	1.59	5.23	1.10
200	1.71	5.62	1.02
300	2.11	6.93	0.827
400	2.45	8.05	0.712
450	2.61	8.56	0.670
500	2.76	9.04	0.634
512	2.79	9.16	0.626
600	3.03	9.95	0.576
700	3.29	10.8	0.531
800	3.53	11.6	0.495
824	3.59	11.8	0.487
894	3.75	12.3	0.466
960	3.89	12.8	0.449
1000	3.98	13.0	0.439
1250	4.48	14.7	0.390
1500	4.94	16.2	0.354
1700	5.29	17.4	0.330
1800	5.46	17.9	0.320
2000	5.78	19.0	0.302
2100	5.94	19.5	0.294
2200	6.09	20.0	0.287
2300	6.24	20.5	0.280
3000	7.23	23.7	0.242
3400	7.75	25.4	0.226
4000	8.49	27.8	0.206
5000	9.63	31.6	0.182
6000	10.7	35.1	0.164
8000	12.6	41.4	0.138
10000	14.4	47.2	0.121
12000	16.1	52.7	0.109
13400	17.2	56.3	0.102

Standard Conditions:

For attenuation, VSWR 1.0, ambient temperature 20°C (68°F).

For Average Power, VSWR 1.0, ambient temperature 40°C (104°F), inner conductor temperature 100°C (212°F), no solar loading.

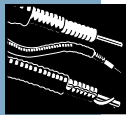

N Male
F2PNM-H



7-16 DIN Female
F2PDF



7-16 DIN Male
F2PDM-C



N Female
F2PNF



7-16 DIN Male
Right Angle
F2PDR-C

Connectors

Interface	Description	Type Number	Inner Contact Attachment	Outer Contact Attachment	Plating Code	Max. Length in (mm)	Max. Dia. in (mm)
N Male	Hex Head	F2PNM-H	Solder	Self-Flare	SG	1.9 (48)	0.94 (23)
N Male	Hex Head	F2PNM-HC	Captivated	Self-Flare	SG	1.9 (48)	0.94 (23)
N Female		F2PNF	Solder	Self-Flare	SG	2.1 (53)	0.67 (17)
N Female		F2PNF-C	Captivated	Self-Flare	SG	2.1 (53)	0.64 (16)
N Female	Bulkhead	F2PNF-BH	Solder	Self-Flare	SG	2.1 (53)	0.95 (24)
7-16 DIN Male		F2PDM	Solder	Self-Flare	SS	2.2 (57)	1.4 (36)
7-16 DIN Male		F2PDM-C	Captivated	Self-Flare	SS	2.1 (53)	1.4 (36)
7-16 DIN Female		F2PDF	Solder	Self-Flare	SS	2.2 (56)	1.1 (28)
7-16 DIN Female		F2PDF-C	Captivated	Self-Flare	SS	2.1 (51.6)	0.79 (20)
7-16 DIN Female	Panel Mt.	F2PDF-PM	Solder	Self-Flare	SS	2.2 (56)	1.1 (28)
7-16 DIN Male	Right Angle	F2PDR-C	Captivated	Self-Flare	SS	1.7/1.3 (43/34)	1.4 (36)

Plating Codes: SG - Silver Plated Body and Gold Plated Pin, SS - Silver Plated Body and Pin, BS - Brass Body and Silver Plated Pin.

Accessories

Description	Type No.
Hangers – For more hangers, adapters and mounting hardware see pages 599-607.	
Insulated Hanger , single. Recommended maximum spacing is 2.5 ft (0.76 m). For different spacing recommendations, refer to Cable Hanger Spacing, page 593-598.	11662-3
Angle Adapter , for insulated hanger	40430-1
Nylon Cable Tie Kit of 50, Indoor use, Recommended maximum spacing is 1.5 ft (0.5 m)	40417
Nylon Cable Tie Kit in plastic box. 100 each 4, 5.5 and 7.5 inch ties. Indoor use, Recommended maximum spacing is 1.5 ft (0.5 m)	CT-K350
Velcro Cable Ties , Black, 8 inch. Indoor Use	
Kit of 10	VCT8-10
Kit of 50	VCT8-50
Kit of 100	VCT8-100
Grounding and Surge Protection – for additional grounding kits and our surge protection offerings, see pages 609-616.	
Standard Grounding Kit	
Factory attached one-hole lug, 24" lead	223158
Factory attached two-hole lug, 24" lead	223158-2
Field attached one-hole lug, 36" lead	223158-3

Connector Accessories – See page 624

Factory Attached Connectors – For factory made cable assemblies and jumper cables, see pages 584-587.

Accessories

Description	Type No.
Weatherproofing – for additional weatherproofing information see pages 617-618.	
Connector/Splice Weatherproofing Kit	221213
Entry Systems – For entry systems offerings see pages 619-620.	
Standard Cable Entry Boots	
4" Boots – One Hole:	204679A-19
5" Boots – Three Hole:	48939A-16
Tools – for additional tool offerings see pages 620-623.	
EASIX® Cutting Tool FSJ2/FSJ4	241372
N Connector Coupling Torque Wrench	244379

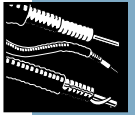

3/8" High Power, High Temperature Plenum Rated, Air Dielectric, HST Series – 50-ohm



HST2-50

Description	Type No.
Cable Ordering Information	
High Power, High Temperature, Plenum Cable	
3/8" Cable	HST2-50
Characteristics	
Electrical	
Impedance, ohms	50 ± 1
Maximum Frequency, GHz	13.4
Velocity, percent	83
Peak Power Rating, kW	13.2
dc Resistance, ohms/1000 ft (1000 m)	
Inner	1.41 (4.64)
Outer	1.52 (4.99)
dc Breakdown, volts	2300
Jacket Spark, volts RMS	5000
Capacitance, pF/ft (m)	23.61 (77.47)
Inductance, µH/ft (m)	0.064 (0.208)
Mechanical	
Outer Conductor	Copper
Inner Conductor	Silver Plated, Copper-Clad Aluminum
Diameter over Jacket, in (mm)	0.415 (10.5)
Diameter over Copper Outer Conductor, in (mm)	0.375 (9.5)
Minimum Bending Radius, in (mm)	1 (25)
Number of Bends, minimum	20 (50)
Bending Moment, lb-ft (N·m)	1.8 (2.45)
Cable Weight, lb/ft. (kg/m)	0.094 (0.140)
Tensile Strength, lb (kg)	210 (95)
Flat Plate Crush Strength, lb/in (kg/mm)	100 (1.8)

Attenuation and Average Power Ratings

Frequency MHz	Attenuation dB/100 ft	Attenuation dB/100 m	Average Power, kW
0.5	0.085	0.279	13.2
1	0.120	0.395	13.2
1.5	0.147	0.484	13.2
2	0.170	0.559	13.2
10	0.383	1.26	13.2
20	0.543	1.78	12.3
30	0.667	2.19	9.98
50	0.865	2.84	7.70
88	1.16	3.79	5.76
100	1.23	4.05	5.40
108	1.28	4.21	5.19
150	1.52	4.99	4.38
174	1.64	5.39	4.06
200	1.76	5.79	3.77
300	2.18	7.15	3.06
400	2.54	8.32	2.63
450	2.70	8.85	2.47
500	2.85	9.36	2.34
512	2.89	9.48	2.31
600	3.14	10.3	2.12
700	3.41	11.2	1.95
800	3.66	12.0	1.82
824	3.72	12.2	1.79
894	3.89	12.8	1.71
960	4.04	13.3	1.65
1000	4.13	13.6	1.61
1250	4.67	15.3	1.43
1500	5.16	16.9	1.29
1700	5.52	18.1	1.21
1800	5.70	18.7	1.17
2000	6.04	19.8	1.10
2100	6.21	20.4	1.07
2200	6.37	20.9	1.05
2300	6.53	21.4	1.02
3000	7.59	24.9	0.878
3400	8.15	26.7	0.818
4000	8.95	29.4	0.745
5000	10.2	33.4	0.655
6000	11.3	37.2	0.588
8000	13.4	44.1	0.496
10000	15.4	50.5	0.433
12000	17.2	56.5	0.387
13400	18.4	60.5	0.362

Standard Conditions:

For attenuation. VSWR 1.0, ambient temperature 20°C (68°F).

For Average Power, VSWR 1.0, ambient temperature 40°C (104°F), inner conductor temperature 200°C (392°F), no solar loading.



N Male
F2PNM-H



7-16 DIN Female
F2PDF



7-16 DIN Male
F2PDM-C



N Female
F2PNF



7-16 DIN Male
Right Angle
F2PDR-C

Connectors

Interface	Description	Type Number	Inner Contact Attachment	Outer Contact Attachment	Plating Code	Max. Length in (mm)	Max. Dia. in (mm)
N Male	Hex Head	F2PNM-H	Solder	Self-Flare	SG	1.9 (48)	0.94 (23)
N Male	Hex Head	F2PNM-HC	Captivated	Self-Flare	SG	1.9 (48)	0.94 (23)
N Female		F2PNF	Solder	Self-Flare	SG	2.1 (53)	0.67 (17)
N Female		F2PNF-C	Captivated	Self-Flare	SG	2.1 (53)	0.64 (16)
N Female	Bulkhead	F2PNF-BH	Solder	Self-Flare	SG	2.1 (53)	0.95 (24)
7-16 DIN Male		F2PDM	Solder	Self-Flare	SS	2.2 (57)	1.4 (36)
7-16 DIN Male		F2PDM-C	Captivated	Self-Flare	SS	2.1 (53)	1.4 (36)
7-16 DIN Female		F2PDF	Solder	Self-Flare	SS	2.2 (56)	1.1 (28)
7-16 DIN Female		F2PDF-C	Captivated	Self-Flare	SS	2.1 (51.6)	0.79 (20)
7-16 DIN Female	Panel Mt.	F2PDF-PM	Solder	Self-Flare	SS	2.2 (56)	1.1 (28)
7-16 DIN Male	Right Angle	F2PDR-C	Captivated	Self-Flare	SS	1.7/1.3 (43/34)	1.4 (36)

Plating Codes: SG - Silver Plated Body and Gold Plated Pin, SS - Silver Plated Body and Pin, BS - Brass Body and Silver Plated Pin.

Accessories

Description	Type No.
Hangers – For more hangers, adapters and mounting hardware see pages 599-607.	
Insulated Hanger , single. Recommended maximum spacing is 2.5 ft (0.76 m). For different spacing recommendations, refer to Cable Hanger Spacing, page 593-598.	11662-3
Angle Adapter , for insulated hanger	40430-1
Nylon Cable Tie Kit of 50, Indoor use, Recommended maximum spacing is 1.5 ft (0.5 m)	40417
Nylon Cable Tie Kit in plastic box. 100 each 4, 5.5 and 7.5 inch ties. Indoor use, Recommended maximum spacing is 1.5 ft (0.5 m)	CT-K350
Velcro Cable Ties , Black, 8 inch. Indoor Use	
Kit of 10	VCT8-10
Kit of 50	VCT8-50
Kit of 100	VCT8-100
Grounding and Surge Protection – for additional grounding kits and our surge protection offerings, see pages 609-616.	
Standard Grounding Kit	
Factory attached one-hole lug, 24" lead	223158
Factory attached two-hole lug, 24" lead	223158-2
Field attached one-hole lug, 36" lead	223158-3

Connector Accessories – See page 624

Factory Attached Connectors – For factory made cable assemblies and jumper cables, see pages 584-587.

Accessories

Description	Type No.
Weatherproofing – for additional weatherproofing information see pages 617-618.	
Connector/Splice Weatherproofing Kit	221213
Entry Systems – For entry systems offerings see pages 619-620.	
Standard Cable Entry Boots	
4" Boots – One Hole:	204679A-19
5" Boots – Three Hole:	48939A-16
Tools – for additional tool offerings see pages 620-623.	
EASIX® Cutting Tool FSJ2/FSJ4	241372
N Connector Coupling Torque Wrench	244379



1/2" Air Dielectric, HJ Series – 50-ohm



HJ4-50

Description	Type No.
Cable Ordering Information	
Standard and Fire Retardant Cables	
1/2" Standard Cable, Standard Jacket	HJ4-50
1/2" Fire Retardant Jacket (CATVR)	HJ4RN-50
Low VSWR and Specialized Cables	
1/2" Low VSWR, specify operating band	HJ4P-50-(**)
Cable for Cellular, standard jacket 824-960 MHz, 1.20 VSWR, max.	HJ4P-50-5

** Insert suffix number from "Low VSWR Specifications" table, page 537.

Characteristics

Electrical	
Impedance, ohms	50 ± 1
Maximum Frequency, GHz	10.9
Velocity, percent	91.4
Peak Power Rating, kW	21.0
dc Resistance, ohms/1000 ft (1000 m)	
Inner	0.45 (1.48)
Outer	0.40 (1.31)
dc Breakdown, volts	2900
Jacket Spark, volts RMS	8000
Capacitance, pF/ft (m)	22.2 (73.0)
Inductance, µH/ft (m)	0.056 (0.182)
Mechanical	
Outer Conductor	Copper
Inner Conductor	Copper
Diameter over Jacket, in (mm)	0.58 (14.7)
Diameter over Copper Outer Conductor, in (mm)	0.50 (12.7)
Diameter Inner Conductor, in (mm)	0.165 (4.2)
Nominal Inside Transverse Dimensions, cm	0.90
Minimum Bending Radius, in (mm)	5 (125)
Number of Bends, minimum (typical)	15 (20)
Bending Moment, lb-ft (N·m)	8 (10.9)
Cable Weight, lb/ft (kg/m)	0.25 (0.37)
Tensile Strength, lb (kg)	700 (320)
Flat Plate Crush, lb/in (kg/mm)	250 (4.5)

Attenuation and Average Power Ratings

Frequency MHz	Attenuation dB/100 ft	Attenuation dB/100 m	Average Power, kW
0.5	0.0560	0.184	21.0
1	0.0792	0.260	21.0
1.5	0.0971	0.319	20.0
2	0.112	0.37	17.3
10	0.253	0.83	7.69
20	0.359	1.18	5.41
30	0.442	1.45	4.40
50	0.574	1.88	3.38
88	0.768	2.52	2.53
100	0.821	2.69	2.37
108	0.854	2.80	2.27
150	1.01	3.33	1.91
174	1.10	3.60	1.77
200	1.18	3.87	1.65
300	1.46	4.80	1.33
400	1.71	5.60	1.14
450	1.82	5.96	1.07
500	1.92	6.31	1.01
512	1.95	6.39	1.00
600	2.12	6.97	0.914
700	2.31	7.58	0.840
800	2.49	8.16	0.781
824	2.53	8.29	0.768
894	2.64	8.68	0.734
960	2.75	9.03	0.706
1000	2.81	9.23	0.690
1250	3.19	10.5	0.609
1500	3.53	11.6	0.549
1700	3.80	12.5	0.512
2000	4.17	13.7	0.466
2300	4.52	14.8	0.430
3000	5.28	17.3	0.368
4000	6.27	20.6	0.310
5000†	7.17	23.5	0.271
6000	8.03	26.3	0.242
8000	9.61	31.5	0.202
10000	11.1	36.4	0.175
10900	11.7	38.4	0.166

Standard Conditions:

For Attenuation, VSWR 1.0 ambient temperature 20°C (68°F), atmospheric pressure, dry air.

For Average Power, VSWR 1.0, inner temperature 100°C (212°F), ambient temperature 40°C (104°F), atmospheric pressure, dry air, no solar loading.

† Operation of this cable in the 5350-5500 MHz band is not recommended because of VSWR spikes produced by the dielectric section spacing.

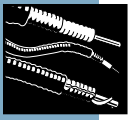

N Male
H4PNM



N Female
H4PNF

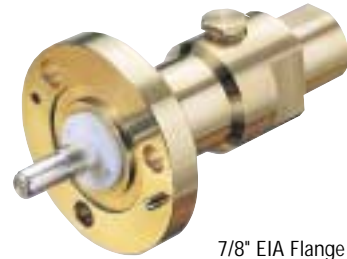

7/8" EIA Flange
H4MPB-014

Connectors

Interface	Description	Type Number	Reference*	Inner Contact Attachment	Outer Contact Attachment	Plating Code	Max. Length in (mm)	Max. Dia. in (mm)
N Male		H4PNM		Solder	Self-Flare	SG	2.8 (71)	1.0 (25)
N Female		H4PNF		Solder	Self-Flare	SG	2.8 (71)	1.0 (25)
7-16 DIN Male		H4PDM		Spring Finger	Self-Flare	SS	2.6 (66)	1.3 (33)
7/8" EIA Flange	Gas Pass/ Barrier Option	H4MPB-014	74ARG	Solder	Self-Flare	BB	3.3 (84)	2.25 (57)
End Terminal		74T		Solder	Self-Flare	BB	4.6 (117)	0.9 (23)
Splice		74Z		Solder	Self-Flare	BB	4.9 (124)	1.1 (28)

Plating Codes: BB - Brass Body and Pin, SG - Silver Plated Body and Gold Plated Pin, SS - Silver Plated Body and Pin

* Previous Type Number.

Connector Accessories

	Type Number
Connector Reattachment Kit for H4PNF, H4PNM, 74PN, 74PW	34767A-22
Bulkhead Adapter, for N Females	26016-2
7/8" EIA Gas Barrier	1260A



Low VSWR Specifications, Type HJ4P-50-()

Frequency Band, GHz	Type No.	Using Connector Type**	Assembly VSWR, Maximum (R.L., dB)	
			1-20 ft (0.3-6 m)	Above 20 ft (6 m)
0.94-1.45 *	HJ4P-50-1	N Male: H4PNM , N Female: H4PNF	1.20 (20.8)	1.25 (19.9)
1.7-2.3	HJ4P-50-4	N Male: H4PNM	1.10 (26.4)	1.15 (23.1)
		N Female: H4PNF	1.15 (23.1)	1.20 (20.8)
		7/8" EIA: H4MPB-014	1.10 (26.4)	1.15 (23.1)
3.625-4.2 *	HJ4P-50-2	N Male: H4PNM , N Female: H4PNF	1.30 (17.7)	1.35 (16.6)

* Specify operating band

** Connectors ordered separately.

VSWR values are guaranteed for factory fit assemblies and are typical for cut lengths. If two different connector interfaces are selected, the higher VSWR value is guaranteed.

Accessories

Description	Type No.
Hangers – For more hangers, adapters and mounting hardware see pages 599-607.	
Standard Hangers Kit of 10. Recommended maximum spacing is 3-ft (1 m). For different spacing recommendations, refer to Cable Hanger Spacing, page 593-598.	43211A
Hardware Kit of 10. 3/8" bolts, lockwashers, nuts	
3/4" (19mm) long	31769-5
1" (25mm) long	31769-1
Snap-In Hangers Kit of 10. For pre-punched 3/4" (19mm) holes on tower member or adapters. Recommended maximum spacing is 3-ft (1 m). For different spacing recommendations, refer to Cable Hanger Spacing, page 593-598.	206706-1
Standard Hoisting Grip	43094

Grounding and Surge Protection – for additional grounding kits and our surge protection offerings, see pages 609-616.

Standard Grounding Kit with standard weatherproofing	
Factory attached one-hole lug, 600 mm (24") lead	204989-1
Factory attached two-hole lug, 600 mm (24") lead	241088-1
Field attached two-hole lug, 1500 mm (60") lead	241545

Description	Type No.
Weatherproofing – for additional weatherproofing information see pages 617-618.	
Connector/Splice Weatherproofing Kit	221213
Entry Systems – For entry systems offerings see pages 619-620.	
Standard Cable Entry Boots	4" Boots 5" Boots
One Hole:	204679A-6 48939A-7
Three Hole:	204679A-1 48939A-5



1/2" High Power, High Temperature, Air Dielectric, HT Series – 50-ohm

HT4-50

Description	Type No.
Cable Ordering Information	
Standard Cable	
1/2" Standard Cable, Unjacketed	HT4-50
Characteristics	
Electrical	
Impedance, ohms	50 ± 1
Maximum Frequency, GHz	10.9
Velocity, percent	92.0
Peak Power Rating, kW	21.0
dc Resistance, ohms/1000 ft (1000 m)	
Inner	0.45 (1.48)
Outer	0.40 (1.31)
dc Breakdown, volts	2900
Capacitance, pF/ft (m)	22.0 (72.2)
Inductance, µH/ft (m)	0.056 (0.182)
Mechanical	
Outer Conductor	Copper
Inner Conductor	Copper
Diameter over Copper Conductor, in (mm)	0.50 (12.7)
Minimum Bending Radius, in (mm)	5 (125)
Number of Bends, minimum (typical)	15 (30)
Bending Moment, lb-ft (N·m)	7.3 (9.9)
Cable Weight, lb/ft (kg/m)	0.21 (0.31)
Tensile Strength, lb (kg)	830 (380)
Flat Plate Crush, lb/in (kg/mm)	290 (5.3)

Attenuation and Average Power Ratings

Frequency MHz	Attenuation dB/100 ft	Attenuation dB/100 m	Average Power, kW
0.5	0.0580	0.190	21.0
1	0.0822	0.270	21.0
1.5	0.101	0.331	21.0
2	0.117	0.383	21.0
10	0.265	0.870	20.8
20	0.379	1.24	14.5
30	0.468	1.54	11.8
50	0.613	2.01	9.00
88	0.829	2.72	6.65
100	0.888	2.91	6.21
108	0.926	3.04	5.96
150	1.11	3.63	4.98
174	1.20	3.94	4.59
200	1.30	4.26	4.25
300	1.63	5.35	3.38
400	1.92	6.31	2.87
450	2.06	6.75	2.68
500	2.19	7.18	2.52
512	2.22	7.28	2.49
600	2.43	7.99	2.27
700	2.67	8.75	2.07
800	2.89	9.48	1.91
824	2.94	9.65	1.88
894	3.09	10.1	1.79
960	3.23	10.6	1.71
1000	3.31	10.9	1.67
1250	3.79	12.4	1.45
1500	4.25	13.9	1.30
1700	4.60	15.1	1.20
2000	5.10	16.7	1.08
2300	5.59	18.3	0.987
3000	6.65	21.8	0.829
4000	8.07	26.5	0.683
5000†	9.41	30.9	0.586
6000	10.7	35.1	0.516
8000	13.1	43.1	0.420
10000	15.5	50.7	0.357
10900	16.5	54.0	0.335

Standard Conditions:

For Attenuation, VSWR 1.0 ambient temperature 20°C (68°F), atmospheric pressure, dry air.

For Average Power, VSWR 1.0, inner temperature 200°C (392°F), ambient temperature 40°C (104°F), atmospheric pressure, dry air, no solar loading.

† Operation of this cable in the 5400-5600 MHz band is not recommended because of VSWR spikes produced by the dielectric section spacing.



N Male
H4PNM



N Female
H4PNF

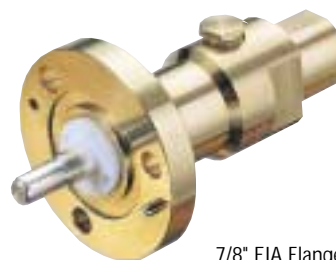

7/8" EIA Flange
H4MPB-014

Connectors

Interface	Description	Type Number	Reference*	Inner Contact Attachment	Outer Contact Attachment	Plating Code	Max. Length in (mm)	Max. Dia. in (mm)
N Male		H4PNM		Solder	Self Flare	SG	2.8 (71)	1.0 (25)
N Female		H4PNF		Solder	Self Flare	SG	2.8 (71)	1.0 (25)
7-16 DIN Male		H4PDM		Spring Finger	Self Flare	SS	2.6 (66)	1.3 (33)
7/8" EIA Flange	Gas Pass/ Barrier Option	H4MPB-014	74ARG	Solder	Self Flare	BB	3.3 (84)	2.25 (57)
End Terminal		74T		Solder	Self Flare	BB	4.6 (117)	0.9 (23)
Splice		74Z		Solder	Self Flare	BB	4.9 (124)	1.1 (28)

Plating Codes: BB - Brass Body and Pin, SG - Silver Plated Body and Gold Plated Pin, SS - Silver Plated Body and Pin

* Previous Type Number.

Connector Accessories

	Type Number
Connector Reattachment Kit for H4PNF, H4PNM, 74PN, 74PW	34767A-22
Bulkhead Adapter, for N Females	26016-2
7/8" EIA Gas Barrier	1260A

Accessories

Description	Type No.
Hangers – For more hangers, adapters and mounting hardware see pages 599-607.	
Standard Hangers Kit of 10. Recommended maximum spacing is 3-ft (1 m). For different spacing recommendations, refer to Cable Hanger Spacing, page 593-598.	43211A
Hardware Kit of 10. 3/8" bolts, lockwashers, nuts	
3/4" (19mm) long	31769-5
1" (25mm) long	31769-1
Standard Hoisting Grip	43094

Description	Type No.
Grounding and Surge Protection – for additional grounding kits and our surge protection offerings, see pages 609-616.	
Standard Grounding Kit with standard weatherproofing	
Factory attached one-hole lug, 600 mm (24") lead	204989-1
Factory attached two-hole lug, 600 mm (24") lead	241088-1
Field attached two-hole lug, 1500 mm (60") lead	241545

Weatherproofing – for additional weatherproofing information see pages 617-618.	
Connector/Splice Weatherproofing Kit	221213

Entry Systems – For entry systems offerings see pages 619-620.		
Standard Cable Entry Boots	4" Boots	5" Boots
One Hole:	204679A-6	48939A-7
Three Hole:	204679A-1	48939A-5

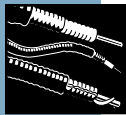

**1/2" Air Dielectric,
Plenum Rated (CATVP),
HL Series – 50-ohm**

HL4RP-50

Description	Type No.
Cable Ordering Information	
Plenum Cable	
1/2" Fire Retardant Cable, Fire Retardant Jacket (CATVP)	HL4RP-50
Characteristics	
Electrical	
Impedance, ohms	50 ± 2
Maximum Frequency, GHz	6.0
Velocity, percent	88.0
Peak Power Rating, kW	21.0
dc Resistance, ohms/1000 ft (1000 m)	
Inner	0.45 (1.48)
Outer	0.58 (1.90)
dc Breakdown, volts	4000
Capacitance, pF/ft (m)	23.0 (75.3)
Inductance, µH/ft (m)	0.058 (0.191)
Mechanical	
Outer Conductor	Copper
Inner Conductor	Copper-Clad Aluminum
Diameter over Jacket, in (mm)	0.61 (15.5)
Diameter over Copper Outer Conductor, in (mm)	0.55 (14)
Minimum Bending Radius, in (mm)	5 (125)
Number of Bends, minimum (typical)	10 (15)
Bending Moment, lb-ft (N·m)	3.0 (4.1)
Cable Weight, lb/ft (kg/m)	0.18 (0.27)
Tensile Strength, lb (kg)	250 (114)
Flat Plate Crush, lb/in (kg/mm)	80 (1.4)

Attenuation and Average Power Ratings

Frequency MHz	Attenuation dB/100 ft	Attenuation dB/100 m	Average Power, kW
0.5	0.049	0.162	40.0
1	0.070	0.229	37.8
1.5	0.086	0.281	30.9
2	0.099	0.324	26.7
10	0.223	0.730	11.9
20	0.317	1.04	8.34
30	0.389	1.28	6.78
50	0.506	1.66	5.22
88	0.678	2.22	3.89
100	0.725	2.38	3.64
108	0.754	2.47	3.50
150	0.896	2.94	2.95
174	0.968	3.18	2.73
200	1.04	3.42	2.53
300	1.29	4.24	2.04
400	1.51	4.95	1.75
450	1.61	5.28	1.64
500	1.70	5.59	1.55
512	1.73	5.66	1.53
600	1.88	6.17	1.40
700	2.05	6.72	1.29
800	2.20	7.23	1.20
824	2.24	7.35	1.18
894	2.34	7.69	1.13
960	2.44	8.00	1.08
1000	2.50	8.19	1.06
1250	2.83	9.29	0.933
1500	3.14	10.3	0.841
1700	3.37	11.1	0.783
1800	3.49	11.4	0.758
2000	3.71	12.2	0.713
2100	3.81	12.5	0.693
2200	3.92	12.9	0.675
2300	4.02	13.2	0.657
3000	4.70	15.4	0.562
3400	5.07	16.6	0.521
4000	5.59	18.3	0.473
5000	6.41	21.0	0.412
6000	7.18	23.6	0.368

Standard Conditions:

For Attenuation, VSWR 1.0 ambient temperature 20°C (68°F).

For Average Power, VSWR 1.0, ambient temperature 40°C (104°F), inner conductor temperature 100°C (212°F), no solar loading.



Connectors

Interface	Description	Type Number	Inner Contact Attachment	Outer Contact Attachment	Plating Code	Max. Length in (mm)	Max. Dia. in (mm)
N Male	Hex Head	L4PNM-H	Solder	Self-Flare	SG	2.6 (66)	0.95 (24.1)
N Male	RingFlare	L4PNM-RC	Captivated	RingFlare	SG	3.0 (75.7)	0.86 (21.8)
N Male	Right Angle, Hex	L4PNR-H	Solder	Self-Flare	SG	3.2/1.5 (81/38)	0.95 (24.1)
N Male	Right Angle, Hex	L4PNR-HC	Captivated	Self-Flare	SG	3.2/1.5 (81/38)	0.91 (23.1)
N Female	-	L4PNF	Solder	Self-Flare	SG	2.6 (66)	0.94 (23.9)
N Female	Bulk Head	L4PNF-BH	Solder	Self-Flare	SG	2.6 (66)	0.96 (24.4)
N Female	Panel Mount	L4PNF-PM	Solder	Self-Flare	SG	2.6 (66)	1.0 (25.4)
N Female	RingFlare	L4PNF-RC	Captivated	RingFlare	SG	2.8 (71)	0.86 (21.8)
7-16 DIN Male	-	L4PDM	Solder	Self-Flare	SS	2.6 (66)	1.4 (35.6)
7-16 DIN Male	Right Angle	L4PDR	Solder	Self-Flare	SS	1.8/2.8 (46/72)	1.41 (35.9)
7-16 DIN Male	Right Angle	L4PDR-C	Captivated	Self-Flare	SS	1.8/2.8 (46/72)	1.41 (35.9)
7-16 DIN Male	RingFlare	L4PDM-RC	Captivated	RingFlare	SS	2.64 (67.1)	0.86 (21.8)
7-16 DIN Female	-	L4PDF	Solder	Self-Flare	SS	2.7 (69)	1.1 (27.9)
7-16 DIN Female	Bulk Head	L4PDF-BH	Solder	Self-Flare	SS	2.73 (69.4)	1.62 (41.1)
7-16 DIN Female	Bulk Head	L4PDF-BHC	Captivated	Self-Flare	SS	2.9 (74)	1.63 (41.4)
7-16 DIN Female	Panel Mount	L4PDF-PM	Solder	Self-Flare	SS	2.7 (69)	1.2 (29.4)
7-16 DIN Female	RingFlare	L4PDF-RC	Captivated	RingFlare	SS	2.8 (71)	0.86 (21.8)
7/8" EIA Flange	-	L44R	Solder	Self-Flare	BB	3.2 (81)	2.25 (57.2)
7/8" EIA Flange	Right Angle	124990-1	Solder	Self-Flare	BB	2.3/1.6 (58/41)	2.25 (57.2)
F Flange Male	-	L44F	Solder	Self-Flare	BB	2.3 (58)	2.25 (57.2)
F Flange Female	-	209865	Solder	Self-Flare	BS	2.3 (58)	2.25 (57.2)
UHF Male	-	L44P	Solder	Self-Flare	BB	2.3 (58)	0.91 (23.1)
UHF Female	-	L44U	Solder	Self-Flare	BS	2.3 (58)	0.91 (23.1)
HN Male	-	L44J	Solder	Self-Flare	BB	2.5 (64)	0.91 (23.1)
LC Male	-	L44M	Solder	Self-Flare	BB	3.6 (91)	0.91 (23.1)
TNC Female	-	L44NT	Solder	Self-Flare	BB	2.8 (71)	0.94 (23.9)
End Terminal	-	L44T	Solder	Self-Flare	BB	4.0 (102)	0.91 (23.1)
Splice	-	L44Z	Solder	Self-Flare	BB	3.2 (81)	1.1 (27.9)

Plating Codes: BB - Brass Body and Pin, BS - Brass Body and Silver Plated Pin, SG - Silver Plated Body and Gold Plated Pin, SS - Silver Plated Body and Pin

Connector Accessories – See page 624

Factory Attached Connectors – For factory made cable assemblies and jumper cables, see pages 584-587.



Accessories

Description	Type No.
Hangers – For more hangers, adapters and mounting hardware see pages 599-607.	
Standard Hangers Kit of 10. Recommended maximum spacing is 3-ft (1 m). For different spacing recommendations, refer to Cable Hanger Spacing, page 593-598.	43211A
Hardware Kit of 10. 3/8" bolts, lockwashers, nuts	
3/4" (19mm) long	31769-5
1" (25mm) long	31769-1
Standard Hoisting Grip	43094

Grounding and Surge Protection – for additional grounding kits and our surge protection offerings, see pages 609-616.

SureGround Grounding Kit with standard weatherproofing	
Factory attached one-hole lug, 600 mm (24") lead	SGL4-06B1
Factory attached two-hole lug, 600 mm (24") lead	SGL4-06B2
Field attached two-hole lug, 1500 mm (59") lead	SGL4-15B4
SureGround Plus Grounding Kit with weatherproofing boot	
Factory attached one-hole lug, 600 mm (24") lead	SGPL4-06B1
Factory attached two-hole lug, 600 mm (24") lead	SGPL4-06B2
Field attached two-hole lug, 1500 mm (59") lead	SGPL4-15B4

Description	Type No.
Weatherproofing – for additional weatherproofing information see pages 617-618.	
Cold Shrink Weatherproofing Kit	
1/2" Coax N Connector to 1/2" Coax N Connector	241474-4
5/8" Coax to 1/2" Coax	242475-13
7/8" Coax to 1/2" Coax	241475-9
1-1/4" or 1-5/8" Coax to 1/2" Coax	241475-5A
2-1/4" Coax to 1/2" Coax	241475-8
1/2" to 1-1/2" Omni/Panel base Type N or DIN	241548-8
1/2" LDF4 to Antenna Type N interface	241548-4
Connector/Splice Weatherproofing Kit	221213

Entry Systems – For entry systems offerings see pages 619-620.

Standard Cable Entry Boots	4" Boots	5" Boots
One Hole:	204679A-5	48939A-6
Three Hole:	204679A-7	48939A-8
Four Hole	204679A-16	48939A-17

Tools – for additional tool offerings see pages 620-623.

EASIX [®] Cutting Tool	207866
DIN Connector Coupling Torque Wrench	244377
N Connector Coupling Torque Wrench	244379



1/2" Air Dielectric, High Power High Temperature, HLT Series – 50-ohm



HLT4-50T

Description	Type No.
Cable Ordering Information	
Plenum Cable	
1/2" Fire Retardant Cable, Fire Retardant Jacket (CATVP, UL910)	HLT4-50T
Characteristics	
Electrical	
Impedance, ohms	52.5 ± 2
Maximum Frequency, GHz	4.0
Velocity, percent	93.0
Peak Power Rating, kW	21.4
dc Resistance, ohms/1000 ft (1000 m)	
Inner	0.45 (1.48)
Outer	0.58 (1.90)
dc Breakdown, volts	3000
Capacitance, pF/ft (m)	20.4 (66.8)
Inductance, µH/ft (m)	0.058 (0.191)
Mechanical	
Outer Conductor	Copper
Inner Conductor	Copper-Clad Aluminum
Diameter over Jacket, in (mm)	0.61 (15.5)
Diameter over Copper Outer Conductor, in (mm)	0.55 (14)
Diameter Inner Conductor, in (mm)	0.189 (4.8)
Minimum Bending Radius, in (mm)	5 (125)
Number of Bends, minimum (typical)	10 (15)
Bending Moment, lb-ft (N•m)	3.0 (4.1)
Cable Weight, lb/ft (kg/m)	0.18 (0.27)
Tensile Strength, lb (kg)	250 (114)
Flat Plate Crush, lb/in (kg/mm)	100 (1.8)

Attenuation and Average Power Ratings

Frequency MHz	Attenuation dB/100 ft	Attenuation dB/100 m	Average Power, kW
0.5	0.047	0.153	21.4
1	0.066	0.217	21.4
1.5	0.081	0.266	21.4
2	0.094	0.308	21.4
10	0.213	0.700	21.4
20	0.305	1.00	15.7
30	0.377	1.24	12.7
50	0.494	1.62	9.72
88	0.669	2.20	7.18
100	0.718	2.35	6.70
108	0.748	2.45	6.42
150	0.896	2.94	5.36
174	0.973	3.19	4.94
200	1.05	3.45	4.57
300	1.32	4.34	3.64
400	1.56	5.12	3.08
450	1.67	5.48	2.88
500	1.78	5.83	2.70
512	1.80	5.91	2.67
600	1.98	6.50	2.43
700	2.17	7.12	2.22
800	2.35	7.72	2.04
824	2.40	7.86	2.01
894	2.52	8.26	1.91
960	2.63	8.63	1.83
1000	2.70	8.85	1.78
1250	3.10	10.2	1.55
1500	3.48	11.4	1.38
1700	3.77	12.4	1.28
1800	3.91	12.8	1.23
2000	4.18	13.7	1.15
2100	4.32	14.2	1.11
2200	4.45	14.6	1.08
2300	4.58	15.0	1.05
3000	5.47	17.9	0.881
3400	5.95	19.5	0.809
4000	6.65	21.8	0.724

Standard Conditions:

For Attenuation, VSWR 1.0 ambient temperature 20°C (68°F).

For Average Power, VSWR 1.0, ambient temperature 40°C (104°F), inner conductor temperature 200°C (392°F), no solar loading.



N Male
L4PNM-RC



N Female
L4PNF-RC



7-16 DIN Male
L4PDM-RC



7-16 DIN Female
L4PDF-RC



7/8" EIA Flange
L44R



UHF Male
L44P

Connectors

Interface	Description	Type Number	Inner Contact Attachment	Outer Contact Attachment	Plating Code	Max. Length in (mm)	Max. Dia. in (mm)
N Male	Hex Head	L4PNM-H	Solder	Self-Flare	SG	2.6 (66)	0.95 (24.1)
N Male	RingFlare	L4PNM-RC	Captivated	RingFlare	SG	3.0 (75.7)	0.86 (21.8)
N Male	Right Angle, Hex	L4PNR-H	Solder	Self-Flare	SG	3.2/1.5 (81/38)	0.95 (24.1)
N Male	Right Angle	L4PNR-HC	Captivated	Self-Flare	SG	3.2/1.5 (81/38)	0.91 (23.1)
N Female	-	L4PNF	Solder	Self-Flare	SG	2.6 (66)	0.94 (23.9)
N Female	Bulk Head	L4PNF-BH	Solder	Self-Flare	SG	2.6 (66)	0.96 (24.4)
N Female	Panel Mount	L4PNF-PM	Solder	Self-Flare	SG	2.6 (66)	1.0 (25.4)
N Female	RingFlare	L4PNF-RC	Captivated	RingFlare	SG	2.8 (71)	0.86 (21.8)
7-16 DIN Male	-	L4PDM	Solder	Self-Flare	SS	2.6 (66)	1.4 (35.6)
7-16 DIN Male	Right Angle	L4PDR	Solder	Self-Flare	SS	1.8/2.8 (46/72)	1.41 (35.9)
7-16 DIN Male	Right Angle	L4PDR-C	Captivated	Self-Flare	SS	1.8/2.8 (46/72)	1.41 (35.9)
7-16 DIN Male	RingFlare	L4PDM-RC	Captivated	RingFlare	SS	2.64 (67.1)	0.86 (21.8)
7-16 DIN Female	-	L4PDF	Solder	Self-Flare	SS	2.7 (69)	1.1 (27.9)
7-16 DIN Female	Bulk Head	L4PDF-BH	Solder	Self-Flare	SS	2.73 (69.4)	1.62 (41.1)
7-16 DIN Female	Bulk Head	L4PDF-BHC	Captivated	Self-Flare	SS	2.9 (74)	1.63 (41.4)
7-16 DIN Female	Panel Mount	L4PDF-PM	Solder	Self-Flare	SS	2.7 (69)	1.2 (29.4)
7-16 DIN Female	RingFlare	L4PDF-RC	Captivated	RingFlare	SS	2.8 (71)	0.86 (21.8)
7/8" EIA Flange	-	L44R	Solder	Self-Flare	BB	3.2 (81)	2.25 (57.2)
7/8" EIA Flange	Right Angle	124990-1	Solder	Self-Flare	BB	2.3/1.6 (58/41)	2.25 (57.2)
F Flange Male	-	L44F	Solder	Self-Flare	BB	2.3 (58)	2.25 (57.2)
F Flange Female	-	209865	Solder	Self-Flare	BS	2.3 (58)	2.25 (57.2)
UHF Male	-	L44P	Solder	Self-Flare	BB	2.3 (58)	0.91 (23.1)
UHF Female	-	L44U	Solder	Self-Flare	BS	2.3 (58)	0.91 (23.1)
HN Male	-	L44J	Solder	Self-Flare	BB	2.5 (64)	0.91 (23.1)
LC Male	-	L44M	Solder	Self-Flare	BB	3.6 (91)	0.91 (23.1)
TNC Female	-	L44NT	Solder	Self-Flare	BB	2.8 (71)	0.94 (23.9)
End Terminal	-	L44T	Solder	Self-Flare	BB	4.0 (102)	0.91 (23.1)
Splice	-	L44Z	Solder	Self-Flare	BB	3.2 (81)	1.1 (27.9)

Plating Codes: BB - Brass Body and Pin, BS - Brass Body and Silver Plated Pin, SG - Silver Plated Body and Gold Plated Pin, SS - Silver Plated Body and Pin

Connector Accessories – See page 624

Factory Attached Connectors – For factory made cable assemblies and jumper cables, see pages 584-587.

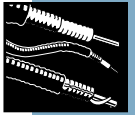

Accessories

Description	Type No.
Hangers – For more hangers, adapters and mounting hardware see pages 599-607.	
Standard Hangers Kit of 10. Recommended maximum spacing is 3-ft (1 m). For different spacing recommendations, refer to Cable Hanger Spacing, page 593-598.	43211A
Hardware Kit of 10. 3/8" bolts, lockwashers, nuts	
3/4" (19 mm) long	31769-5
1" (25 mm) long	31769-1
Standard Hoisting Grip	43094

Grounding and Surge Protection – for additional grounding kits and our surge protection offerings, see pages 609-616.

SureGround Grounding Kit with standard weatherproofing	
Factory attached one-hole lug, 600 mm (24") lead	SGL4-06B1
Factory attached two-hole lug, 600 mm (24") lead	SGL4-06B2
Field attached two-hole lug, 1500 mm (59") lead	SGL4-15B4
SureGround Plus Grounding Kit with weatherproofing boot	
Factory attached one-hole lug, 600 mm (24") lead	SGPL4-06B1
Factory attached two-hole lug, 600 mm (24") lead	SGPL4-06B2
Field attached two-hole lug, 1500 mm (59") lead	SGPL4-15B4

Accessories

Description	Type No.
Weatherproofing – for additional weatherproofing information see pages 617-618.	
Cold Shrink Weatherproofing Kit	
1/2" Coax N Connector to 1/2" Coax N Connector	241474-4
5/8" Coax to 1/2" Coax	242475-13
7/8" Coax to 1/2" Coax	241475-9
1-1/4" or 1-5/8" Coax to 1/2" Coax	241475-5A
2-1/4" Coax to 1/2" Coax	241475-8
1/2" to 1-1/2" Omni/Panel base Type N or DIN	241548-8
1/2" LDF4 to Antenna Type N interface	241548-4
Connector/Splice Weatherproofing Kit	221213

Entry Systems – For entry systems offerings see pages 619-620.

Standard Cable Entry Boots	4" Boots	5" Boots
One Hole:	204679A-5	48939A-6
Three Hole:	204679A-7	48939A-8
Four Hole	204679A-16	48939A-17

Tools – for additional tool offerings see pages 620-623.

EASIA [®] X Cutting Tool	207866
DIN Connector Coupling Torque Wrench	244377
N Connector Coupling Torque Wrench	244379



**1/2" Air Dielectric,
Plenum Rated (CATVP),
HS Series – 50-ohm**

HS4RP-50

Description	Type No.
Cable Ordering Information	
Plenum Cable	
1/2" Fire Retardant Cable	HS4RP-50
Characteristics	
Electrical	
Impedance, ohms	50 ± 2
Maximum Frequency, GHz	10.2
Velocity, percent	81
Peak Power Rating, kW	15.6
dc Resistance, ohms/1000 ft (1000 m)	
Inner	0.87 (2.85)
Outer	1.00 (3.28)
dc Breakdown, volts	2500
Jacket Spark, volts RMS	5000
Capacitance, pF/ft (m)	25.04 (82.16)
Inductance, µH/ft (m)	0.063 (0.206)
Mechanical	
Outer Conductor	Copper
Inner Conductor	Copper-Clad Aluminum
Diameter over Jacket, in (mm)	0.52 (13.2)
Diameter over Copper Outer Conductor, in (mm)	0.48 (12.2)
Minimum Bending Radius, in (mm)	1.25 (32)
Number of Bends, minimum	20 (50)
Bending Moment, lb-ft (N•m)	4.5 (6.12)
Cable Weight, lb/ft (kg/m)	0.138 (0.205)
Tensile Strength, lb (kg)	175 (80)
Flat Plate Crush Strength, lb/in (kg/mm)	110 (1.9)

Attenuation and Average Power Ratings

Frequency MHz	Attenuation dB/100 ft	Attenuation dB/100 m	Average Power, kW
0.5	0.065	0.214	15.6
1	0.092	0.303	15.6
1.5	0.113	0.372	15.0
2	0.131	0.429	13.0
10	0.294	0.965	5.77
20	0.417	1.37	4.07
30	0.512	1.68	3.31
50	0.664	2.18	2.55
88	0.887	2.91	1.91
100	0.947	3.11	1.79
108	0.985	3.23	1.72
150	1.17	3.83	1.46
174	1.26	4.13	1.35
200	1.35	4.44	1.25
300	1.67	5.48	1.02
400	1.94	6.37	0.874
450	2.07	6.78	0.821
500	2.19	7.17	0.777
512	2.21	7.26	0.767
600	2.41	7.90	0.705
700	2.61	8.57	0.650
800	2.81	9.21	0.605
824	2.85	9.35	0.595
894	2.98	9.77	0.570
960	3.09	10.2	0.549
1000	3.16	10.4	0.537
1250	3.57	11.7	0.476
1500	3.94	12.9	0.431
1700	4.22	13.9	0.402
1800	4.36	14.3	0.390
2000	4.62	15.2	0.368
2100	4.75	15.6	0.358
2200	4.87	16.0	0.349
2300	4.99	16.4	0.340
3000	5.79	19.0	0.293
3400	6.22	20.4	0.273
4000	6.82	22.4	0.249
5000	7.76	25.5	0.219
6000	8.63	28.3	0.197
8000	10.2	33.6	0.166
10000	11.7	38.4	0.145
10200	11.8	38.8	0.144

Standard Conditions:

For Attenuation. VSWR 1.0 ambient temperature 20°C (68°F).

For Average Power, VSWR 1.0, ambient temperature 40°C (104°F), inner conductor temperature 100°C (212°F), no solar loading.



Connectors

Interface	Description	Type Number	Inner Contact Attachment	Outer Contact Attachment	Plating Code	Max. Length in (mm)	Max. Dia. in (mm)
N Male	Hex Head	F4PNMV2-H	Solder	Crush-Flare	SG	2.13 (54.0)	0.94 (23.8)
N Male	Hex Head	F4PNMV2-HC	Captivated	Crush-Flare	SG	2.13 (54.0)	0.94 (23.8)
N Male	Rt Angle, Hex Hd	F4PNR-H	Solder	Tab-Flare	SG	3.3/1.5 (84/38)	0.86 (21.8)
N Male		F4PNR-HC	Captivated	Crush-Flare	SG	2.8 (71.9)/1.6 (41.5)	1 (25.7)
N Female	-	F4PNF	Solder	Self-Flare	SG	2.3 (53.3)	0.88 (22.4)
N Female	-	F4PNF-C	Captivated	Self-Flare	SG	2.3 (53.3)	0.88 (22.4)
N Female	Bulkhead	F4PNF-BH	Solder	Self-Flare	SG	2.3 (58)	0.95 (24.1)
4.1/9.5 DIN Male	-	F4PKM-C	Captivated	Self-Flare	SS	2.0 (50)	0.95 (24.1)
4.1/9.5 DIN Male	Rt Angle, Outdoor Use	F4PKR-C	Captivated	Self-Flare	SS	2.3/1.5 (57/38)	0.95 (24.1)
7-16 DIN Male	-	F4PDMV2-C	Captivated	Crush-Flare	SS	1.98 (50.2)	1.05 (26.7)
7-16 DIN Male	-	F4PDMV2	Solder	Crush-Flare	SS	2.10 (53.4)	1.05 (26.7)
7-16 DIN Male	Right Angle	F4PDR	Solder	Self-Flare	SS	2.4/1.8 (61/46)	1.4 (35.6)
7-16 DIN Male	Right Angle	F4PDR-C	Captivated	Self-Flare	SS	2.1/2.0 (53/50)	1.4 (35.6)
7-16 DIN Female	-	F4PDF-C	Captivated	Self-Flare	SS	2.0 (50)	1.1 (27.9)
7-16 DIN Female	-	F4PDF	Solder	Self-Flare	SS	2.0 (50)	1.1 (27.9)
7-16 DIN Female	Bulkhead	F4PDF-BH	Solder	Self-Flare	SS	2.01 (51.1)	1.50 (38)
7-16 DIN Female	Panel Mount	F4PDF-PM	Solder	Self-Flare	SS	2.01 (51.1)	1.26 (32)
7-16 DIN Female	Bulkhead	F4PDF-BHC	Captivated	Self-Flare	SS	2.0 (50)	1.8 (45.7)
7-16 DIN Female	Panel Mount	F4PDF-PMC	Captivated	Self-Flare	SS	2.0 (50)	1.3 (33)
7/8\" EIA Flange	-	44ASR	Solder	Tab-Flare	BS	3.3 (84)	1.4 (35.6)
UHF Male	-	44ASP	Solder	Tab-Flare	BS	2.1 (53)	0.84 (21.3)
UHF Female	-	44ASU	Solder	Tab-Flare	BS	2.3 (58)	0.84 (21.3)
HN Male	-	44ASJ	Solder	Tab-Flare	BB	2.4 (61)	0.84 (21.3)
SC Male	-	44SPCW	Solder	Tab-Flare	SG	2.7 (69)	0.88 (22.4)

Plating Codes: BB - Brass Body and Pin, BS - Brass Body and Silver Plated Pin, SG - Silver Plated Body and Gold Plated Pin, SS - Silver Plated Body and Pin

Connector Accessories – See page 624

Factory Attached Connectors – For factory made cable assemblies and jumper cables, see pages 584-587.

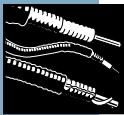

Accessories

Description	Type No.
Hangers – For more hangers, adapters and mounting hardware see pages 599-607.	
Standard Hangers Kit of 10. Recommended maximum spacing is 3-ft (1 m). For different spacing recommendations, refer to Cable Hanger Spacing, page 593-598.	43211A
Hardware Kit of 10. 3/8" bolts, lockwashers, nuts	
3/4" (19 mm) long	31769-5
1" (25 mm) long	31769-1
Standard Hoisting Grip	43094
Grounding and Surge Protection – for additional grounding kits and our surge protection offerings, see pages 609-616.	
Standard Grounding Kits	
Factory attached one-hole lug 24"	204989-1
Factory attached two-hole lug 24"	241088-1
Field attached two-hole lug 60"	241545

Description	Type No.
Weatherproofing – for additional weatherproofing information see pages 617-618.	
Connector/Splice Weatherproofing Kit	221213
Entry Systems – For entry systems offerings see pages 619-620.	
Standard Cable Entry Boots	4" Boots 5" Boots
One Hole:	204679A-5 48939A-6
Three Hole:	204679A-7 48939A-8
Four Hole:	204679A-16 48939A-17
Tools – for additional tool offerings see pages 620-623.	
EASIAX® Cutting Tool FSJ4/FSJ1	207865
DIN Connector Coupling Torque Wrench	244377
N Connector Coupling Torque Wrench	244379



1/2" High Power, High Temperature, Plenum Rated Air Dielectric, HST Series – 50-ohm



HST4-50

Description	Type No.
-------------	----------

Cable Ordering Information

High Power, High Temperature, Plenum Cable	
1/2" Cable	HST4-50

Characteristics

Electrical	
Impedance, ohms	50 ± 2
Maximum Frequency, GHz	10.2
Velocity, percent	81
Peak Power Rating, kW	15.6
dc Resistance, ohms/1000 ft (1000 m)	
Inner	0.87 (2.85)
Outer	1.00 (3.28)
dc Breakdown, volts	2500
Jacket Spark, volts RMS	4000
Capacitance, pF/ft (m)	25.04 (82.16)
Inductance, µH/ft (m)	0.063 (0.206)
Mechanical	
Outer Conductor	Copper
Inner Conductor	Silver Plated, Copper-Clad Aluminum
Diameter over Jacket, in (mm)	0.52 (13.2)
Diameter over Copper Outer Conductor, in (mm)	0.48 (12.2)
Minimum Bending Radius, in (mm)	1.25 (32)
Number of Bends, minimum	20 (50)
Bending Moment, lb-ft (N•m)	4.57 (6.22)
Cable Weight, lb/ft (kg/m)	0.165 (0.245)
Tensile Strength, lb (kg)	175 (80)
Flat Plate Crush Strength, lb/in (kg/mm)	110 (1.9)

Attenuation and Average Power Ratings

Frequency MHz	Attenuation dB/100 ft	Attenuation dB/100 m	Average Power, kW
0.5	0.074	0.244	15.6
1	0.105	0.345	15.6
1.5	0.129	0.423	15.6
2	0.149	0.489	15.6
10	0.335	1.10	15.6
20	0.477	1.56	15.6
30	0.586	1.92	15.6
50	0.762	2.50	13.3
88	1.02	3.35	9.92
100	1.09	3.58	9.29
108	1.13	3.72	8.92
150	1.35	4.42	7.52
174	1.46	4.78	6.95
200	1.57	5.14	6.46
300	1.94	6.38	5.21
400	2.27	7.44	4.47
450	2.42	7.93	4.19
500	2.56	8.39	3.96
512	2.59	8.50	3.91
600	2.82	9.27	3.59
700	3.07	10.1	3.30
800	3.31	10.9	3.06
824	3.36	11.0	3.01
894	3.52	11.5	2.88
960	3.66	12.0	2.77
1000	3.74	12.3	2.71
1250	4.24	13.9	2.39
1500	4.71	15.4	2.15
1700	5.05	16.6	2.00
1800	5.22	17.1	1.94
2000	5.55	18.2	1.83
2100	5.71	18.7	1.78
2200	5.86	19.2	1.73
2300	6.02	19.7	1.68
3000	7.04	23.1	1.44
3400	7.58	24.9	1.34
4000	8.36	27.4	1.21
5000	9.57	31.4	1.06
6000	10.7	35.1	0.947
8000	12.8	42.1	0.790
10000	14.8	48.6	0.685
10200	15.0	49.2	0.676

Standard Conditions:

For Attenuation, VSWR 1.0 ambient temperature 20°C (68°F).

For Average Power, VSWR 1.0, ambient temperature 40°C (104°F), inner conductor temperature 200°C (392°F), no solar loading.



N Male
F4PNMV2-H



N Female Bulkhead
F4PNF-BH



UHF Male
44ASP



N Male Right Angle
F4PNR-H

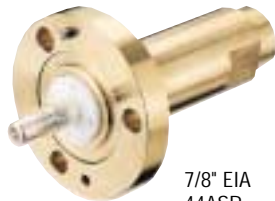

7/8" EIA
44ASR



7-16 DIN Female
F4PDF-C



7-16 DIN Male
F4PDMV2-C

Connectors

Interface	Description	Type Number	Inner Contact Attachment	Outer Contact Attachment	Plating Code	Max. Length in (mm)	Max. Dia. in (mm)
N Male	Hex Head	F4PNMV2-H	Solder	Crush-Flare	SG	2.13 (54.0)	0.94 (23.8)
N Male	Hex Head	F4PNMV2-HC	Captivated	Crush-Flare	SG	2.13 (54.0)	0.94 (23.8)
N Male	Rt Angle, Hex Hd	F4PNR-H	Solder	Tab-Flare	SG	3.3/1.5 (84/38)	0.86 (21.8)
N Male	–	F4PNR-HC	Captivated	Crush-Flare	SG	2.8 (71.9)/1.6 (41.5)	1 (25.7)
N Female	–	F4PNF	Solder	Self-Flare	SG	2.3 (53.3)	0.88 (22.4)
N Female	–	F4PNF-C	Captivated	Self-Flare	SG	2.3 (53.3)	0.88 (22.4)
N Female	Bulkhead	F4PNF-BH	Solder	Self-Flare	SG	2.3 (58)	0.95 (24.1)
4.1/9.5 DIN Male	–	F4PKM-C	Captivated	Self-Flare	SS	2.0 (50)	0.95 (24.1)
4.1/9.5 DIN Male	Rt Angle, Outdoor Use	F4PKR-C	Captivated	Self-Flare	SS	2.3/1.5 (57/38)	0.95 (24.1)
7-16 DIN Male	–	F4PDMV2-C	Captivated	Crush-Flare	SS	1.98 (50.2)	1.05 (26.7)
7-16 DIN Male	–	F4PDMV2	Solder	Crush-Flare	SS	2.10 (53.4)	1.05 (26.7)
7-16 DIN Male	Right Angle	F4PDR	Solder	Self-Flare	SS	2.4.1.8 (61/46)	1.4 (35.6)
7-16 DIN Male	Right Angle	F4PDR-C	Captivated	Self-Flare	SS	2.1/2.0 (53/50)	1.4 (35.6)
7-16 DIN Female	–	F4PDF-C	Captivated	Self-Flare	SS	2.0 (50)	1.1 (27.9)
7-16 DIN Female	–	F4PDF	Solder	Self-Flare	SS	2.0 (50)	1.1 (27.9)
7-16 DIN Female	Bulkhead	F4PDF-BH	Solder	Self-Flare	SS	2.01 (51.1)	1.50 (38)
7-16 DIN Female	Panel Mount	F4PDF-PM	Solder	Self-Flare	SS	2.01 (51.1)	1.26 (32)
7-16 DIN Female	Bulkhead	F4PDF-BHC	Captivated	Self-Flare	SS	2.0 (50)	1.8 (45.7)
7-16 DIN Female	Panel Mount	F4PDF-PMC	Captivated	Self-Flare	SS	2.0 (50)	1.3 (33)
7/8" EIA Flange	–	44ASR	Solder	Tab-Flare	BS	3.3 (84)	1.4 (35.6)
UHF Male	–	44ASP	Solder	Tab-Flare	BS	2.1 (53)	0.84 (21.3)
UHF Female	–	44ASU	Solder	Tab-Flare	BS	2.3 (58)	0.84 (21.3)
HN Male	–	44ASJ	Solder	Tab-Flare	BB	2.4 (61)	0.84 (21.3)
SC Male	–	44SPCW	Solder	Tab-Flare	SG	2.7 (69)	0.88 (22.4)

Plating Codes: BB - Brass Body and Pin, BS - Brass Body and Silver Plated Pin, SG - Silver Plated Body and Gold Plated Pin, SS - Silver Plated Body and Pin

Connector Accessories – See page 624

Factory Attached Connectors – For factory made cable assemblies and jumper cables, see pages 584-587.

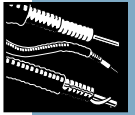

Accessories

Description	Type No.
Hangers – For more hangers, adapters and mounting hardware see pages 599-607.	
Standard Hangers Kit of 10. Recommended maximum spacing is 3-ft (1 m). For different spacing recommendations, refer to Cable Hanger Spacing, page 593-598.	43211A
Hardware Kit of 10. 3/8" bolts, lockwashers, nuts	
3/4" (19 mm) long	31769-5
1" (25 mm) long	31769-1
Standard Hoisting Grip	43094
Grounding and Surge Protection – for additional grounding kits and our surge protection offerings, see pages 609-616.	
Standard Grounding Kits	
Factory attached one-hole lug 24"	204989-1
Factory attached two-hole lug 24"	241088-1
Field attached one-hole lug 36"	204989-21
Field attached two-hole lug 60"	241545

Description	Type No.	
Weatherproofing – for additional weatherproofing information see pages 617-618.		
Connector/Splice Weatherproofing Kit	221213	
Entry Systems – For entry systems offerings see pages 619-620.		
Standard Cable Entry Boots	4" Boots	5" Boots
One Hole:	204679A-5	48939A-6
Three Hole:	204679A-7	48939A-8
Four Hole:	204679A-16	48939A-17
Tools – for additional tool offerings see pages 620-623.		
EASIA [®] X Cutting Tool FSJ4/FSJ1	207865	
DIN Connector Coupling Torque Wrench	244377	
N Connector Coupling Torque Wrench	244379	



5/8" Air Dielectric, HJ Series – 50-ohm

HJ4.5-50

Description	Type No.
Cable Ordering Information	
Standard and Fire Retardant Cables	
5/8" Standard Cable, Standard Jacket	HJ4.5-50
5/8" Fire Retardant Jacket (CATVR)	HJ4.5RN-50
Low VSWR and Specialized Cables	
5/8" Low VSWR, specify operating band	HJ4.5P-50-(**)
Cable for Cellular, standard jacket	
824-960 MHz, 1.20 VSWR, max.	HJ4.5P-50-1
880-960 MHz, 1.10 VSWR, max.	HJ4.5P-50-2
** Insert suffix number from "Low VSWR Specifications" table.	
Characteristics	
Electrical	
Impedance, ohms	50 ± 1
Maximum Frequency, GHz	6.6
Velocity, percent	92
Peak Power Rating, kW	40
dc Resistance, ohms/1000 ft (1000 m)	
Inner	0.41 (1.35)
Outer	0.23 (0.75)
dc Breakdown, volts	4000
Jacket Spark, volts RMS	5500
Capacitance, pF/ft (m)	22.3 (73.2)
Inductance, μH/ft (m)	0.056 (0.182)
Mechanical	
Outer Conductor	Copper
Inner Conductor	Copper
Diameter over Jacket, in (mm)	0.875 (22.2)
Diameter over Copper Outer Conductor, in (mm)	0.775 (19.7)
Diameter Inner Conductor, in (mm)	0.272 (6.9)
Nominal Inside Transverse Dimensions (cm)	1.51
Minimum Bending Radius, in (mm)	7 (180)
Number of Bends, minimum (typical)	15 (20)
Bending Moment, lb-ft (N·m)	16 (21.7)
Cable Weight, lb/ft (kg/m)	0.40 (0.59)
Tensile Strength, lb (kg)	750 (340)
Flat Plate Crush Strength, lb/in (kg/mm)	250 (4.5)

Attenuation and Average Power Ratings

Frequency MHz	Attenuation dB/100 ft	Attenuation dB/100 m	Average Power, kW
0.5	0.034	0.110	40.0
1	0.048	0.156	40.0
1.5	0.058	0.192	40.0
2	0.067	0.221	35.30
10	0.152	0.497	15.64
20	0.215	0.706	10.98
30	0.264	0.867	8.94
50	0.343	1.12	6.90
88	0.457	1.50	5.17
100	0.488	1.60	4.84
108	0.508	1.67	4.65
150	0.602	1.98	3.92
200	0.699	2.29	3.38
300	0.863	2.83	2.73
400	1.00	3.29	2.35
450	1.07	3.51	2.20
500	1.13	3.71	2.09
600	1.24	4.09	1.89
700	1.35	4.43	1.74
800	1.45	4.76	1.62
824	1.47	4.85	1.59
894	1.54	5.05	1.52
960	1.60	5.25	1.47
1000	1.64	5.37	1.43
1250	1.85	6.07	1.27
1500	2.04	6.70	1.16
2000	2.40	7.86	0.986
3000	3.01	9.89	0.784
4000*	3.55	11.6	0.665
5000	4.04	13.3	0.585
6000	4.49	14.8	0.525
6600	4.75	15.6	0.496

Standard Conditions:

For Attenuation. VSWR 1.0 ambient temperature 20°C (68°F), atmospheric pressure, dry air.

For Average Power. VSWR 1.0, inner temperature 100°C (212°F), ambient temperature 40°C (104°F), atmospheric pressure, dry air, no solar loading.

* Operation of this cable in the 4250-4400 MHz band is not recommended because of VSWR spikes produced by the dielectric spacing.



N Male
H4.5PNM



7-16 DIN Male
H4.5PDM

Connectors

Interface	Description	Type Number	Inner Contact Attachment	Outer Contact Attachment	Plating Code	Max. Length in (mm)	Max. Dia. in (mm)
N Male	–	H4.5PNM	Spring Finger	Self Flare	SG	2.6 (66)	1.3 (33)
7-16 DIN Male	–	H4.5PDM	Spring Finger	Self Flare	SS	2.8 (71)	1.3 (33)
Splice	–	85Z	Self-tapping	Self Flare	BB	3.1 (79)	1.6 (41)

Plating Codes: BB - Brass Body and Pin, SG - Silver Plated Body and Gold Plated Pin, SS - Silver Plated Body and Pin.

Connector Accessories

	Type Number
Bulkhead Adapter, for N or UHF Females	26016-2

Low VSWR Specifications, Type HJ4.5-50-()

Frequency Band, GHz	Type No.	Using Connector Type**	Assembly VSWR, Maximum (R.L., dB)				
			1-25 ft (0.3-8 m)	25-100 ft (8-30 m)	100-200 ft (30-60 m)	200-500 ft (60-150 m)	Above 500 ft (150 m)
0.824-0.960	HJ4.5P-50-1	N Plug: H4.5PNM	1.20 (20.8)	1.20 (20.8)	1.20 (20.8)	1.20 (20.8)	1.20 (20.8)
		7-16 DIN male: H4.5PDM	1.20 (20.8)	1.20 (20.8)	1.20 (20.8)	1.20 (20.8)	1.20 (20.8)
0.880-0.960	HJ4.5P-50-2	N Plug: H4.5PNM	1.10 (26.4)	1.10 (26.4)	1.10 (26.4)	1.10 (26.4)	1.10 (26.4)
		7-16 DIN male: H4.5PDM	1.10 (26.4)	1.10 (26.4)	1.10 (26.4)	1.10 (26.4)	1.10 (26.4)
0.940-2.7	HJ4.5P-50-3	N Plug: H4.5PNM	1.20 (20.8)	1.20 (20.8)	1.25 (19.1)	1.25 (19.1)	1.25 (19.1)
		7-16 DIN male: H4.5PDM	1.20 (20.8)	1.20 (20.8)	1.25 (19.1)	1.25 (19.1)	1.25 (19.1)
0.010-0.806	HJ4.5P-50-4	N Plug: H4.5PNM	1.25 (19.1)	1.25 (19.1)	1.30 (17.6)	1.30 (17.6)	1.30 (17.6)
		7-16 DIN male: H4.5PDM	1.25 (19.1)	1.25 (19.1)	1.30 (17.6)	1.30 (17.6)	1.30 (17.6)
0.010-2.7	HJ4.5P-50-5	N Plug: H4.5PNM	1.25 (19.1)	1.25 (19.1)	1.35 (16.5)	1.35 (16.5)	1.35 (16.5)
		7-16 DIN male: H4.5PDM	1.25 (19.1)	1.25 (19.1)	1.35 (16.5)	1.35 (16.5)	1.35 (16.5)
0.010-4.2	HJ4.5P-50-6	N Plug: H4.5PNM	1.30 (17.6)	1.35 (16.5)	1.40 (15.6)	1.50 (19.9)	1.50 (19.9)
		7-16 DIN male: H4.5PDM	1.30 (17.6)	1.35 (16.5)	1.40 (15.6)	1.50 (19.9)	1.50 (19.9)
4.4-6.6	HJ4.5P-50-7	N Plug: H4.5PNM	1.30 (17.6)	1.35 (16.5)	1.40 (15.6)	1.50 (19.9)	1.50 (19.9)
		7-16 DIN male: H4.5PDM	1.30 (17.6)	1.35 (16.5)	1.40 (15.6)	1.50 (19.9)	1.50 (19.9)

* Connectors ordered separately.

VSWR values are guaranteed for factory fit assemblies and are typical for field cut lengths. If two different connector interfaces are selected, the higher VSWR value is guaranteed.



Accessories

Description	Type No.
Hangers – For more hangers, adapters and mounting hardware see pages 599-607.	
Standard Hangers Kit of 10. Recommended maximum spacing is 3 ft (1 m). For different spacing recommendations, refer to Cable Hanger Spacing, page 593-598.	42396A-9
Hardware Kit of 10. 3/8" bolts, lockwashers, nuts	
3/4" (19 mm) long	31769-5
1" (25 mm) long	31769-1
Snap-in Hangers Kit of 10. For prepunched 3/4" (19 mm) holes on tower member or adapters. Recommended maximum spacing is 3-ft (1 m). For different spacing recommendations, refer to Cable Hanger Spacing, page 593-598.	206706-6
Click-On Hangers Kit of 10. Recommended maximum spacing is 3-ft. Mounting Hardware see page 605	L45CLICK
Standard Hoisting Grip	29958

Description	Type No.
Grounding and Surge Protection – for additional grounding kits and our surge protection offerings, see pages 609-616.	
SureGround Grounding Kit with standard weatherproofing	
Factory attached one-hole lug, 600 mm (24") lead	SGL45-06B1
Factory attached two-hole lug, 600 mm (24") lead	SGL45-06B2
Field attached two hole lug, 1500 mm (59") lead	SGL45-15B4
Standard Grounding Kit with standard weatherproofing	
Factory attached one-hole lug, 24" (610 mm) lead	204989-2
Factory attached two-hole lug, 24" (610 mm) lead	241088-2
Field attached two hole lug, 59" (1500 mm) lead	220497
Weatherproofing – for additional weatherproofing information see pages 617-618.	
Connector/Splice Weatherproofing Kit	221213
Entry Systems – For entry systems offerings see pages 619-620.	
Standard Cable Entry Boots	4" Boots 5" Boots
One Hole:	204679A-13 48939A-14
Three Hole:	204679A-14 48939A-15

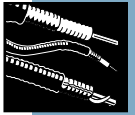

7/8" Air Dielectric, HJ Series – 50-ohm



HJ5-50

Description	Type No.
Cable Ordering Information	
Standard and Fire Retardant Cables	
Maximum VSWR 1.20 (824-960 and 1850-1990 MHz)	
7/8" Standard Cable, Standard Jacket	HJ5-50*
7/8" Fire Retardant Jacket (CATVP)	HJ5RP-50*
7/8" Fire Retardant Jacket (CATVR)	HJ5RN-50*
Low VSWR and Specialized Cables	
7/8" Low VSWR, specify operating band	HJ5P-50-(**)
Cable for Cellular, standard jacket 824-960 or 1850-1990 MHz, 1.10 VSWR, max.	25831-7
* For broadcast applications, specify channel and frequency.	
**Insert suffix number from "Low VSWR Specifications" table, page 557.	
Characteristics	
Electrical	
Impedance, ohms	50 ± 0.5
Maximum Frequency, GHz	5.2
Velocity, percent	91.6
Peak Power Rating, kW	90
dc Resistance, ohms/1000 ft (1000 m)	
Inner	0.25 (0.82)
Outer	0.20 (0.66)
dc Breakdown, volts	6000
Jacket Spark, volts RMS	8000
Capacitance, pF/ft (m)	22.2 (72.8)
Inductance μH/ft (m)	0.055 (0.180)
Mechanical	
Outer Conductor	Copper
Inner Conductor	Copper
Diameter over Jacket, in (mm)	1.11 (28.2)
Diameter over Copper Out Conductor, in (mm)	1.01 (25.7)
Diameter Inner Conductor, in (mm)	0.359 (9.1)
Nominal Inside Transverse Dimensions (cm)	2.02
Minimum Bending Radius, in (mm)	10 (250)
Number of Bends, minimum (typical)	15 (20)
Bending Moment, lb-ft (N·m)	25 (34)
Cable Weight, lb/ft (kg/m)	0.54 (0.80)
Tensile Strength, lb (kg)	800 (360)
Flat Plate Crush Strength, lb/in (kg/mm)	250 (4.5)

Attenuation and Average Power Ratings

Frequency MHz	Attenuation dB/100 ft	Attenuation dB/100 m	Average Power, kW
0.5	0.0250	0.0822	90.0
1	0.0355	0.116	78.4
1.5	0.0435	0.143	63.9
2	0.0503	0.165	55.3
10	0.113	0.372	24.5
20	0.161	0.529	17.3
30	0.198	0.651	14.0
50	0.258	0.846	10.8
88	0.346	1.13	8.05
100	0.369	1.21	7.53
108	0.385	1.26	7.23
150	0.457	1.50	6.09
174	0.494	1.62	5.63
200	0.532	1.75	5.23
300	0.661	2.17	4.21
400	0.772	2.53	3.60
450	0.823	2.70	3.38
500	0.871	2.86	3.19
512	0.883	2.90	3.15
600	0.963	3.16	2.89
700	1.05	3.44	2.65
800	1.13	3.71	2.46
824	1.15	3.77	2.42
894	1.20	3.94	2.31
960	1.25	4.11	2.22
1000	1.28	4.20	2.17
1250	1.45	4.77	1.91
1500	1.61	5.29	1.72
1700	1.73	5.69	1.60
2000	1.91	6.26	1.46
2300	2.07	6.79	1.34
3000†	2.43	7.96	1.15
4000	2.89	9.48	0.963
5000	3.32	10.9	0.839
5200	3.40	11.2	0.818

Standard Conditions:

For Attenuation. VSWR 1.0, ambient temperature 20°C (68°F), atmospheric pressure, dry air.

For average Power. VSWR 1.0 inner temperature 100°C (212°F), ambient temperature 40°C (104°F), atmospheric pressure, dry air, no solar loading.

† Contact Andrew for information on operation in the 3050-3200 MHz band.

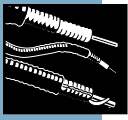

N Female
H5PNF



N Female
H5NF-T



7/8" EIA Flange
75AR



7-16 DIN Male
H5PDM



7-16 DIN Female
H5PDF



N Male
H5PNM

Connectors

Interface	Description	Type Number	Reference*	Inner Contact Attachment	Outer Contact Attachment	Plating Code	Max. Length in (mm)	Max. Dia. in (mm)
N Male	–	H5PNM	–	Self-tapping	Tab Flare	SG	3.5 (89)	1.4 (36)
N Male	Tunable	H5NM-T	–	Self-tapping	Tab Flare	BB	8.5 (216)	1.4 (36)
N Female	–	H5PNF	–	Self-tapping	Tab Flare	SG	3.4 (86)	1.4 (36)
N Female	Tunable	H5NF-T	–	Self-tapping	Tab Flare	BB	8.2 (208)	1.4 (36)
7-16 DIN Male	–	H5PDM	–	Spring Finger	Tab Flare	SS	2.8 (71)	1.4 (36)
7-16 DIN Female	–	H5PDF	–	Spring Finger	Tab Flare	SS	2.8 (71)	1.4 (36)
7/8" EIA Flange	Gas Pass	75AR	–	Self-tapping	Tab Flare	BB	3.7 (94)	2.25 (57)
7/8" EIA Flange	Gas Pass, Tunable	75ART	–	Self-tapping	Tab Flare	BB	5.9 (150)	2.25 (57)
7/8" EIA Flange	Gas Barrier	H5MB-014	75AG	Self-tapping	Tab Flare	BB	3.7 (94)	2.25 (57)
7/8" EIA Flange	Gas Barrier, Tunable	75AGT	–	Self-tapping	Tab Flare	BB	5.9 (150)	2.25 (57)
1-5/8" EIA Flange	Gas Pass/Barrier	H5MPB-110	–	Self-tapping	Tab Flare	BS	5.2 (132)	3.5 (89)
UHF Female	–	75AU	–	Self-tapping	Tab Flare	BS	3.4 (86)	1.4 (36)
LC Male	–	75AM	–	Self-tapping	Tab Flare	BB	5.0 (127)	1.4 (36)
End Terminal	–	75AT	–	Self-tapping	Tab Flare	BB	5.1 (130)	1.4 (36)
Splice	–	75AZ	–	Self-tapping	Tab Flare	BB	4.2 (107)	1.4 (36)

Plating Codes: BB - Brass Body and Pin, BS - Brass Body and Silver Plated Pin, SG - Silver Plated Body and Gold Plated Pin, SS - Silver Plated Body and Pin

* Previous Type Number.

Connector Accessories

	Type Number
Connector Reattachment Kit	
For H5PNF, H5PNM, 75AR, 75PN, 75PW	34767A-3
For 75AG, 75AU	34767A-5
For 75ART, 75AGT	34767A-44
For H5NF-T, 75NT	34767A-18
Bulkhead Adapter, for N or UHF Females	26016-2
90°, 7/8" EIA Miter Elbow, includes one inner connector	1060A



Terrestrial Microwave – Low VSWR Specifications

Frequency Band, GHz	Type Number	Recommended Connectors				VSWR, max. (R.L.)
		7/8" EIA No Gas Barrier	7/8" EIA Gas Barrier	Type N Plug	Type N Jack	
1.7-1.9	HJ5P-50-17L	75ART	75AGT	H5NM-T	H5NF-T	1.08 (28.3)
1.85-1.99	HJ5P-50-18	75ART	75AGT	H5NM-T	H5NF-T	1.08 (28.3)
2.11-2.2	HJ5P-50-21	75ART	75AGT	H5NM-T	H5NF-T	1.08 (28.3)
1.7-2.11	HJ5P-50-17	75ART	75AGT	H5NM-T	H5NF-T	1.08 (28.3)
1.9-2.3	HJ5P-50-19	75ART	75AGT	H5NM-T	H5NF-T	1.08 (28.3)
2.3-2.7	HJ5P-50-23W	75ART	75AGT	H5NM-T	H5NF-T	1.08 (28.3)
3.625-4.2	HJ5P-50-36	-	-	H5PNM	H5PNF	1.20 (20.8)

VSWR values are guaranteed for factory fit assemblies and are typical for field cut lengths. If two different connector interfaces are selected, the higher VSWR value is guaranteed.

Accessories

Description	Type No.
Hangers – For more hangers, adapters and mounting hardware see pages 599-607.	
Standard Hangers Kit of 10. Recommended maximum spacing is 3 ft (1 m). For different spacing recommendations, refer to Cable Hanger Spacing, pages 593-598.	42396A-5
Hardware Kit of 10. 3/8" bolts, lockwashers, nuts	
3/4" (19 mm) long	31769-5
1" (25 mm) long	31769-1
Click-On Hangers Kit of 10. Recommended maximum spacing is 3-ft (1 m). Mounting Hardware see page 605.	L5CLICK
Standard Hoisting Grip	19256B

Description	Type No.
Grounding and Surge Protection – for additional grounding kits and our surge protection offerings, see pages 609-616.	
SureGround Grounding Kit with standard weatherproofing	
Factory attached one-hole lug, 600mm (24") lead	SGL5-06B1
Factory attached two-hole lug, 600mm (24") lead	SGL5-06B2
Field attached two hole lug, 2000mm (79") lead	SGL5-20B4
Weatherproofing – for additional weatherproofing information see pages 617, 618.	
Connector/Splice Weatherproofing Kit	221213
Entry Systems – For entry systems offerings see pages 619, 620.	
Standard Cable Entry Boots	
One Hole:	204679A-2 48939A-1
Two Hole:	204679A-18 -
Three Hole:	204679A-15 48939A-2

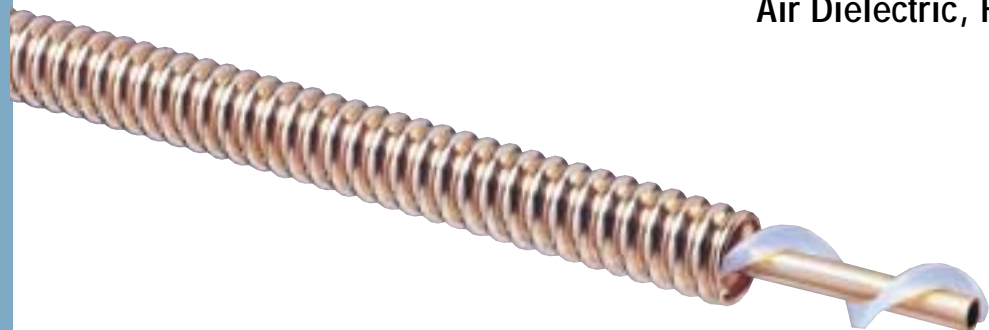

7/8" High Power, High Temperature, Air Dielectric, HT Series – 50-ohm

HT5-50

Description	Type No.
Cable Ordering Information	
Standard Cable	
7/8" Standard Cable, Unjacketed	HT5-50
Characteristics	
Electrical	
Impedance, ohms	50 ± 1
Maximum Frequency, GHz	5.2
Velocity, percent	92.5
Peak Power Rating, kW	90
dc Resistance, ohms/1000 ft (1000 m)	
Inner	0.25 (0.82)
Outer	0.20 (0.66)
dc Breakdown, volts	6000
Capacitance, pF/ft (m)	21.7 (71.2)
Inductance, µH/ft (m)	0.055 (0.182)
Mechanical	
Outer Conductor	Copper
Inner Conductor	Copper Tube
Diameter over Copper Outer Conductor, in (mm)	1.01 (25.5)
Minimum Bending Radius, in (mm)	10 (250)
Number of Bends, minimum (typical)	15 (30)
Bending Moment, lb-ft (N·m)	29 (39.3)
Cable Weight, lb/ft (kg/m)	0.45 (0.67)
Tensile Strength, lb (kg)	800 (360)
Flat Plate Crush Strength, lb/in (kg/mm)	240 (4.3)

Attenuation and Average Power Ratings

Frequency MHz	Attenuation dB/100 ft	Attenuation dB/100 m	Average Power, kW
0.5	0.0253	0.0829	90.0
1	0.0360	0.118	90.0
1.5	0.0442	0.145	90.0
2	0.0512	0.168	90.0
10	0.118	0.387	59.2
20	0.171	0.561	40.8
30	0.213	0.698	32.7
50	0.282	0.925	24.7
88	0.389	1.28	17.9
100	0.419	1.38	16.6
108	0.438	1.44	15.9
150	0.532	1.75	13.1
174	0.581	1.91	11.9
200	0.632	2.07	11.0
300	0.813	2.67	8.59
400	0.972	3.19	7.18
450	1.05	3.44	6.65
500	1.12	3.69	6.21
512	1.14	3.74	6.11
600	1.26	4.15	5.52
700	1.40	4.59	4.99
800	1.53	5.03	4.55
824	1.56	5.13	4.47
894	1.65	5.42	4.23
960	1.73	5.69	4.03
1000	1.78	5.85	3.92
1250	2.08	6.84	3.34
1500	2.37	7.77	2.94
1700	2.59	8.50	2.20
2000	2.91	9.56	1.51
2300	3.24	10.6	1.49
3000†	3.95	13.0	1.46
4000	4.91	16.1	1.42
5000	5.84	19.2	1.19
5200	6.02	19.8	1.16

Standard Conditions:

For Attenuation. VSWR 1.0, ambient temperature 20°C (68°F), atmospheric pressure, dry air.

For average power, VSWR 1.0 inner temperature 200°C (392°F), ambient temperature 40°C (104°F) atmospheric pressure, dry air, no solar loading.

† Operation of this cable in the 3550-3700 MHz band is not recommended because of VSWR spikes produced by the dielectric section spacing.

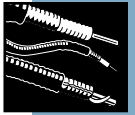

N Female
H5PNF



7-16 DIN Male
H5PDM



7-16 DIN Female
H5PDF



7/8" EIA Flange
75AR



N Male
H5PNM

Connectors

Interface	Description	Type Number	Reference*	Inner Contact Attachment	Outer Contact Attachment	Plating Code	Max. Length in (mm)	Max. Dia. in (mm)
N Male	-	H5PNM	-	Self-tapping	Tab Flare	SG	3.5 (89)	1.4 (36)
N Female	Tunable	H5NF-T	-	Self-tapping	Tab Flare	BB	8.2 (208)	1.4 (36)
7-16 DIN Male	-	H5PDM	-	Spring Finger	Tab Flare	SS	2.8 (71)	1.4 (36)
7-16 DIN Female	-	H5PDF	-	Spring Finger	Tab Flare	SS	2.8 (71)	1.4 (36)
7/8" EIA Flange	Gas Pass	75AR	-	Self-tapping	Tab Flare	BB	3.7 (94)	2.25 (57)
7/8" EIA Flange	Gas Barrier	H5MB-014	75AG	Self-tapping	Tab Flare	BB	3.7 (94)	2.25 (57)
UHF Female	-	75AU	-	Self-tapping	Tab Flare	BS	3.4 (86)	1.4 (36)
LC Male	-	75AM	-	Self-tapping	Tab Flare	BB	5.0 (127)	1.4 (36)
End Terminal	-	75AT	-	Self-tapping	Tab Flare	BB	5.1 (130)	1.4 (36)
Splice	-	75AZ	-	Self-tapping	Tab Flare	BB	4.2 (107)	1.4 (36)

Plating Codes: BB - Brass Body and Pin, BS - Brass Body and Silver Plated Pin, SG - Silver Plated Body and Gold Plated Pin, SS - Silver Plated Body and Pin

* Previous Type Number.

Accessories

Description	Type No.
Hangers – For more hangers, adapters and mounting hardware see pages 599-607.	
Standard Hangers Kit of 10. Recommended maximum spacing is 3 ft (1 m). For different spacing recommendations, refer to Cable Hanger Spacing, pages 593-598.	42396A-5
Hardware Kit of 10. 3/8" bolts, lockwashers, nuts	
3/4" (19 mm) long	31769-5
1" (25 mm) long	31769-1
Standard Hoisting Grip	19256B

Grounding and Surge Protection – for additional grounding kits and our surge protection offerings, see pages 609-616.

SureGround Grounding Kit with standard weatherproofing

Factory attached one-hole lug, 600 mm (24") lead	SGL5-06B1
Factory attached two-hole lug, 600 mm (24") lead	SGL5-06B2
Field attached two hole lug, 1500 mm (59") lead	SGL5-15B4

Connector Accessories

Description	Type Number
Connector Reattachment Kit	
For H5PNF, H5PNM, 75AR, 75PN, 75PW	34767A-3
For 75AG, 75AU	34767A-5
For 75ART, 75AGT	34767A-44
For H5NF-T, 75NT	34767A-18
Bulkhead Adapter , for N or UHF Females	26016-2
90°, 7/8" EIA Miter Elbow, includes one inner connector	1060A

Accessories

Description	Type No.
Weatherproofing – for additional weatherproofing information see pages 617, 618.	
Connector/Splice Weatherproofing Kit	221213

Entry Systems – For entry systems offerings see pages 619, 620.

Standard Cable Entry Boots	4" Boots	5" Boots
One Hole:	204679A-2	48939A-1
Two Hole:	204679A-18	-
Three Hole:	204679A-15	48939A-2



1-5/8" Air Dielectric, HJ Series – 50-ohm

HJ7-50A

Description	Type No.
-------------	----------

Cable Ordering Information

Standard and Fire Retardant Cables

Maximum VSWR 1.20 (824-960 and 1850-1990 MHz)

1-5/8" Standard Cable, Standard Jacket	HJ7-50A
1-5/8" Fire Retardant Jacket (CATVP)	HJ7RP-50A
1-5/8" Fire Retardant Jacket (CATVR)	HJ7RN-50A

Enhanced Power Cable

1-5/8" Cable with Polyolefin Dielectric for 25% increase in power ratings	27591-101
---	-----------

Low VSWR and Specialized Cables

1-5/8" Low VSWR, specify operating band	HJ7P-50A-(**)
1-5/8" Low VSWR, specify operating band	HJ7SP-50A-(**)
Cable for Cellular, standard jacket 824-960 or 1850-1990 MHz, 1.10 VSWR, max.	25816A-33
Broadcast, Low VSWR 54-216 MHz, 1.05 VSWR, max. over broadcast channel	
470-740 MHz, 1.08 VSWR, max. over broadcast channel	
740-856 MHz, 1.10 VSWR, max. over broadcast channel	42140*

* For broadcast applications, specify channel and frequency.

** Insert suffix number from "Low VSWR Specifications" table.

Characteristics

Electrical

Impedance, ohms	50 ± 0.5
Maximum Frequency, GHz	2.7
Velocity, percent	92.1
Peak Power Rating, kW	305
dc Resistance, ohms/1000 ft (1000 m)	
Inner	0.22 (0.72)
Outer	0.10 (0.33)
dc Breakdown, volts	11000
Jacket Spark, volts RMS	10000
Capacitance, pF/ft (m)	22.1 (72.4)
Inductance, µH/ft (m)	0.055 (0.181)

Mechanical

Outer Conductor	Copper
Inner Conductor	Copper
Diameter over Jacket, in (mm)	1.98 (50.3)
Diameter over Copper Outer Conductor, in (mm)	1.83 (46.5)
Diameter Inner Conductor, in (mm)	0.713 (18.1)
Nominal Inside Transverse Dimensions (cm)	3.99
Minimum Bending Radius, in (mm)	20 (510)
Number of Bends, minimum (typical)	15 (30)
Bending Moment, lb-ft (N·m)	30 (40.7)
Cable Weight, lb/ft (kg/m)	1.04 (1.55)
Tensile Strength, lb (kg)	750 (340)
Flat Plate Crush Strength, lb/in (kg/mm)	175 (3.1)

Attenuation and Average Power Ratings

Frequency MHz	Attenuation dB/100 ft	Attenuation dB/100 m	Average Power, kW
0.5	0.0138	0.0452	243
1	0.0195	0.0641	171.8
1.5	0.0239	0.0785	140.2
2	0.0277	0.0908	121.3
10	0.0623	0.205	53.8
20	0.0887	0.291	37.8
30	0.109	0.358	30.8
50	0.142	0.465	23.7
88	0.190	0.623	17.7
100	0.203	0.666	16.5
108	0.211	0.693	15.9
150	0.251	0.823	13.4
174	0.271	0.890	12.4
200	0.292	0.958	11.5
300	0.363	1.19	9.25
400	0.423	1.39	7.93
450	0.451	1.48	7.44
500	0.478	1.57	7.02
512	0.484	1.59	6.93
600	0.528	1.73	6.36
700	0.575	1.89	5.84
800	0.619	2.03	5.42
824	0.629	2.06	5.33
894	0.658	2.16	5.10
960	0.685	2.25	4.90
1000	0.701	2.30	4.79
1250	0.795	2.61	4.22
1700	0.948	3.11	3.54
2000	1.04	3.42	3.22
2300	1.13	3.71	2.97
2700	1.24	4.08	2.70

Standard Conditions:

For Attenuation, VSWR 1.0 ambient temperature 20°C (68°F), atmospheric pressure, dry air.

For Average Power, VSWR 1.0, inner temperature 100°C (212°F), ambient temperature 40°C (104°F), atmospheric pressure, dry air, no solar loading.

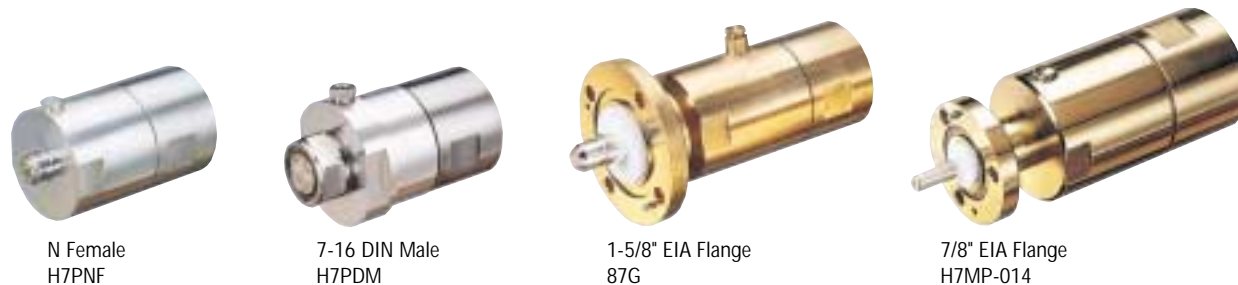
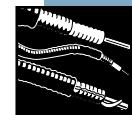

Connectors

Interface	Description	Type Number	Reference*	Inner Contact Attachment	Outer Contact Attachment	Plating Code	Max. Length in (mm)	Max. Dia. in (mm)
N Male	Tunable	H7NM-T	-	Tab Flare	Tab Flare	BB	11.6 (295)	2.4 (61)
N Female	-	H7PNF	-	Tab Flare	Tab Flare	SG	4.1 (104)	2.4 (61)
N Female	Tunable	H7NF-T	-	Tab Flare	Tab Flare	BB	11.4 (290)	2.4 (61)
7-16 DIN Male	-	H7PDM	-	Tab Flare	Tab Flare	SS	4.2 (107)	2.7 (69)
7-16 DIN Female	-	H7PDF	-	Tab Flare	Tab Flare	SS	4.2 (107)	2.7 (69)
1-5/8" EIA Flange	Gas Pass [†]	87R	-	Tab Flare	Tab Flare	BS	4.8 (122)	3.5 (89)
1-5/8" EIA Flange	Gas Block [†]	87G	-	Tab Flare	Tab Flare	BS	5.7 (145)	3.5 (89)
7/8" EIA Flange	Gas Pass [†]	H7MP-014	87S	Tab Flare	Tab Flare	BS	5.6 (142)	2.4 (61)
7/8" EIA Flange	Gas Pass, Tunable [†]	87ST	-	Tab Flare	Tab Flare	BS	11.8 (300)	2.4 (61)
7/8" EIA Flange	Gas Block [†]	H7MB-014	87SG	Tab Flare	Tab Flare	BS	5.6 (142)	2.4 (61)
7/8" EIA Flange	Gas Block, Tunable [†]	87SGT	-	Tab Flare	Tab Flare	BS	12.2 (310)	2.4 (61)
LC Female	-	87L	-	Tab Flare	Tab Flare	BB	4.9 (124)	2.4 (61)
End Terminal	-	87T	-	Tab Flare	Tab Flare	BB	7.0 (178)	2.4 (61)
Splice	-	87Z	-	Tab Flare	Tab Flare	BB	5.9 (150)	2.4 (61)

Plating Codes: BB - Brass Body and Pin, BS - Brass Body and Silver Plated Pin (inner connector), SG - Silver Plated Body and Gold Plated Pin, SS - Silver Plated Body and Pin

* Previous Type Number. † Includes inner.

Connector Accessories

	Type Number
Connector Reattachment Kit	
For 87G, 87R	34767A-6
For H7PNF, 87PN, H7MP-014, H7MB-014	34767A-7
For 87SGT, 87ST	34767A-20
For H7NF-T, H7NM-T, 87NT, 87WT	34767A-19
For 87Z	34767A-13
7/8" EIA Gas Barrier	1260A
1-5/8" EIA Gas Barrier	1261B
1-5/8" EIA End Terminal, for strap connection to center conductor, includes inner connector.	
Use with 87R	2061
1-5/8" Inner Connector, with anchor bead	34660
1-5/8" EIA 90° Miter Elbow, includes one inner connector	1061A



Terrestrial Microwave – Low VSWR Specifications

Frequency Band, GHz	Type Number	Recommended Connectors				VSWR, max. (R.L.)
		7/8" EIA No Gas Barrier	7/8" EIA Gas Barrier	Type N Plug	Type N Jack	
P Series						
1.7-1.9	HJ7P-50A-17L	87ST	87SGT	H7NM-T	H7NF-T	1.15 (23.1)
1.85-1.99	HJ7P-50A-18	H7MP-014*	H7MB-014*	H7NM-T	H7NF-T	1.15 (23.1)
2.11-2.2	HJ7P-50A-21	H7MP-014*	H7MB-014*	H7NM-T	H7NF-T	1.15 (23.1)
1.7-2.11	HJ7P-50A-17	87ST	87SGT	H7NM-T	H7NF-T	1.15 (23.1)
1.9-2.3	HJ7P-50A-19	87ST	87SGT	H7NM-T	H7NF-T	1.15 (23.1)
2.3-2.7	HJ7P-50A-23W	87ST	87SGT	H7NM-T	H7NF-T	1.15 (23.1)
SP Series						
1.7-1.9	HJ7SP-50A-17L	87ST	87SGT	-	-	1.10 (26.4)
1.85-1.99	HJ7SP-50A-18	-	-	H7NM-T	H7NF-T	1.12 (24.8)
2.11-2.2	HJ7SP-50A-21	87ST	87SGT	-	-	1.10 (26.4)
1.7-2.11	HJ7SP-50A-17	87ST	87SGT	H7NM-T	H7NF-T	1.12 (24.8)
1.9-2.3	HJ7SP-50A-19	87ST	87SGT	-	-	1.10 (26.4)
		-	-	H7NM-T	H7NF-T	1.12 (24.8)

* Tunable connector may be used.

VSWR values are guaranteed for factory fit assemblies and are typical for field cut lengths. If two different connector interfaces are selected, the higher VSWR value is guaranteed.

Accessories

Description	Type No.
Hangers – For more hangers, adapters and mounting hardware see pages 599-607.	
Standard Hangers Kit of 10. Recommended maximum spacing is 3 ft (1 m). For different spacing recommendations, refer to Cable Hanger Spacing, pages 593-598.	42396A-2
Hardware Kit of 10. 3/8" bolts, lockwashers, nuts	
3/4" (19 mm) long	31769-5
1" (25 mm) long	31769-1
Click-On Hangers Kit of 10. Recommended maximum spacing is 3-ft (1 m). Mounting Hardware see page 605.	L7CLICK
Standard Hoisting Grip	24312A

Description	Type No.
Grounding and Surge Protection – for additional grounding kits and our surge protection offerings, see pages 609-616.	
SureGround Grounding Kit with standard weatherproofing	
Factory attached one-hole lug, 600 mm (24") lead	SGL7-06B1
Factory attached two-hole lug, 600 mm (24") lead	SGL7-06B2
Field attached two hole lug, 1500 mm (59") lead	SGL7-15B4
Weatherproofing – for additional weatherproofing information see pages 617, 618.	
Connector/Splice Weatherproofing Kit	221213
Entry Systems – For entry systems offerings see pages 619, 620.	
Standard Cable Entry Boots	4" Boots 5" Boots
One Hole:	204679A-4 48939A-4

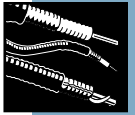

2-1/4" Air Dielectric, HJ Series – 50-ohm



HJ12-50

Description	Type No.
-------------	----------

Cable Ordering Information

Standard and Fire Retardant Cables	
Maximum VSWR 1.20 (824-960 and 1850-1990 MHz)	
2-1/4" Standard Cable, Standard Jacket	HJ12-50
2-1/4" Fire Retardant Jacket (CATVR)	HJ12RN-50
Low VSWR and Specialized Cables	
2-1/4" Low VSWR, specify operating band	HJ12P-50-(**)
Cable for Cellular, standard jacket	
824-960 MHz 1.10 VSWR, max.	207760-3
Broadcast, Low VSWR	
54-216 MHz, 1.05 VSWR, max. over broadcast channel	
470-740 MHz, 1.08 VSWR, max. over broadcast channel	
740-856 MHz, 1.10 VSWR, max. over broadcast channel	207761*

* For broadcast applications, specify channel and frequency.
 **Insert suffix number from "Low VSWR Specifications" table.

Characteristics

Electrical	
Impedance, ohms	50 ± 0.5
Maximum Frequency, GHz	2.3
Velocity, percent	93.1
Peak Power Rating, kW	425
dc Resistance, ohms/1000 ft (1000 m)	
Inner	0.17 (0.56)
Outer	0.075 (0.25)
dc Breakdown, volts	13000
Jacket Spark, volts RMS	10000
Capacitance, pF/ft (m)	21.8 (71.5)
Inductance, µH/ft (m)	0.055 (0.180)
Mechanical	
Outer Conductor	Copper
Inner Conductor	Copper
Diameter over Jacket, in (mm)	2.38 (60.4)
Diameter over Copper Outer Conductor, in (mm)	2.23 (56.6)
Diameter Inner Conductor, in (mm)	0.890 (22.6)
Nominal Inside Transverse Dimension (cm)	4.96
Minimum Bending Radius, in (mm)	22 (560)
Number of Bends, minimum (typical)	15 (50)
Bending Moment, lb-ft (N·m)	55 (75)
Cable Weight, lb/ft (kg/m)	1.16 (1.73)
Tensile Strength, lb (kg)	980 (445)
Flat Plate Crush Strength, lb/in (kg/mm)	145 (2.6)

Attenuation and Average Power Ratings

Frequency MHz	Attenuation dB/100 ft	Attenuation dB/100 m	Average Power, kW
0.5	0.0114	0.0375	342
1	0.0162	0.0531	241.2
1.5	0.0198	0.0651	196.8
2	0.0229	0.0752	170.2
10	0.0517	0.170	75.5
20	0.0736	0.242	53.0
30	0.0906	0.297	43.1
50	0.118	0.387	33.1
88	0.158	0.519	24.7
100	0.169	0.555	23.1
108	0.176	0.577	22.2
150	0.209	0.686	18.7
174	0.226	0.743	17.2
200	0.244	0.800	16.0
300	0.303	0.994	12.9
400	0.354	1.16	11.0
450	0.378	1.24	10.3
500	0.400	1.31	9.76
512	0.405	1.33	9.63
600	0.442	1.45	8.82
700	0.482	1.58	8.10
800	0.519	1.70	7.52
824	0.528	1.73	7.39
894	0.553	1.81	7.06
960	0.576	1.89	6.78
1000	0.589	1.93	6.63
1250	0.669	2.20	5.83
1500	0.744	2.44	5.25
1700	0.800	2.62	4.88
2000	0.880	2.89	4.44
2300	0.956	3.14	4.08

Standard Conditions:

For Attenuation. VSWR 1.0 ambient temperature 20°C (68°F), atmospheric pressure, dry air.

For Average Power. VSWR 1.0, inner temperature 100°C (212°F), ambient temperature 40°C (104°F), atmospheric pressure, dry air, no solar loading.

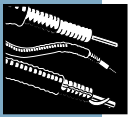

N Female
H12PNF



3-1/8" EIA Flange
82GF



1-5/8" EIA Flange
82R



7/8" EIA Flange
82S

Connectors

Interface	Description	Type Number	Inner Contact Attachment	Outer Contact Attachment	Plating Code	Max. Length in (mm)	Max. Dia. in (mm)
N Female	–	H12PNF	Tab Flare	Tab Flare	SG	4.4 (112)	2.8 (71)
7-16 DIN Male	–	H12PDM	Tab Flare	Tab Flare	SS	4.5 (114)	3.1 (79)
3-1/8" EIA Flange	Gas Pass, Female	82RF	Tab Flare	Tab Flare	BB	6.9 (175)	5.2
3-1/8" EIA Flange	Gas Barrier, Female	82GF	Tab Flare	Tab Flare	BB	6.9 (175)	5.2
1-5/8" EIA Flange	Gas Pass, Male	82R	Tab Flare	Tab Flare	BB	4.8 (122)	3.5 (89)
7/8" EIA Flange	Gas Pass, Male	82S	Tab Flare	Tab Flare	BB	5.7 (145)	2.8 (71)
Splice	–	82Z	Tab Flare	Tab Flare	BB	5.9 (150)	3.4 (86)

Plating Codes: BB - Brass Body and Pin, SG - Silver Plated Body and Gold Plated Pin, SS - Silver Plated Body and Pin

Connector Accessories

	Type Number
Connector Reattachment Kit	
For H12PNF, 82PN	34767A-46
For 82R	34767A-47
For 82RF	34767A-49
For 82GF	34767A-50
1-5/8" EIA Gas Barrier	1261B
1-5/8" EIA End Terminal, for strap connection to center conductor, includes inner connector.	
Use with 82R	2061
1-5/8" Inner Connector, with anchor bead	34660
3-1/8" Inner Connector, with anchor bead	ACX350-20
3-1/8" EIA 90° Miter Elbow, includes inner conductor	ACX350-10SE
1-5/8" EIA 90° Miter Elbow	ACX150-10SE
7/8" EIA 90° Miter Elbow	1060A

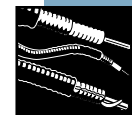

Terrestrial Microwave – Low VSWR Specifications

Frequency Band, GHz	Type Number	Recommended Connectors			VSWR, max. (R.L.)
		7/8" EIA No Gas Barrier	Type N Jack		
1.7-1.9	HJ12P-50-17L	82S	H12PNF		1.15 (23.1)
1.85-1.99	HJ12P-50-18	82S	H12PNF		1.15 (23.1)
2.11-2.2	HJ12P-50-21	82S	H12PNF		1.15 (23.1)

Frequency Band, GHz	Type Number	Recommended Connectors			VSWR, max. (R.L.)
		7/8" EIA No Gas Barrier	Type N Jack		
1.7-2.11	HJ12P-50-17	82S	H12PNF		1.15 (23.1)
1.9-2.3	HJ12P-50-19	82S	H12PNF		1.15 (23.1)

VSWR values are guaranteed for factory fit assemblies and are typical for field cut lengths. If two different connector interfaces are selected, the higher VSWR value is guaranteed.

Accessories

Description	Type No.
Hangers – For more hangers, adapters and mounting hardware see pages 599-607.	
Standard Hangers Kit of 10. Standard tower configuration spacing is 3-4 feet (1-1.2m). For different spacing recommendations, refer to Cable Hanger Spacing, pages 593-598.	42396A-4
Hardware Kit of 10. 3/8" bolts, lock washers, nuts	
3/4" (19 mm) long	31769-5
1" (25 mm) long	31769-1
Snap-In Hangers Kit of 10. For pre-punched 3/4" (19 mm) holes on tower member or adapters. Standard tower configuration spacing is 3-4 feet. (1-1.2m). For different spacing recommendations, refer to Cable Hanger Spacing, pages 593-598.	206706-5
Standard Hoisting Grip	31535

Description	Type No.
Grounding and Surge Protection – for additional grounding kits and our surge protection offerings, see pages 609-616.	
SureGround Grounding Kit with standard weatherproofing	
Factory attached one-hole lug, 600 mm (24") lead	SGL12-06B1
Factory attached two-hole lug, 600 mm (24") lead	SGL12-06B2
Field attached two hole lug, 1500 mm (59") lead	SGL12-15B4
Weatherproofing – for additional weatherproofing information see pages 617, 618.	
Connector/Splice Weatherproofing Kit	221213
Entry Systems – For entry systems offerings see pages 619, 620.	
Standard Cable Entry Boots	4" Boots 5" Boots
One Hole:	204679A-8 48939A-9



3" Air Dielectric, HJ Series – 50-ohm

HJ8-50B

Description	Type No.
-------------	----------

Cable Ordering Information

Standard Cable	
3" Standard Cable, Standard Jacket	HJ8-50B
Low VSWR and Specialized Cables	
Cable for Cellular, standard jacket 824-894 MHz, 1.20 VSWR, max.	209227
Broadcast, Low VSWR	
54-216 MHz, 1.05 VSWR, max. over broadcast channel	
470-740 MHz, 1.08 VSWR, max. over broadcast channel	
740-856 MHz, 1.10 VSWR, max. over broadcast channel	42141*
Cable with Polyethylene Dielectric (12% lower attenuation at 800 MHz)	27591-6

* For broadcast applications, specify channel and frequency.

Characteristics

Electrical	
Impedance, ohms	50 ± 0.5
Maximum Frequency, GHz	1.64
Velocity, percent	93.3
Peak Power Rating, kW	640
dc Resistance, ohms/1000 ft (1000 m)	
Inner	0.15 (0.49)
Outer	0.07 (0.23)
dc Breakdown, volts	16000
Jacket Spark, volts RMS	10000
Capacitance, pF/ft (m)	21.7 (71.2)
Inductance, µH/ft (m)	0.055 (0.18)
Mechanical	
Outer Conductor	Copper
Inner Conductor	Copper
Diameter over Jacket, in (mm)	3.01 (76.6)
Diameter over Copper Outer Conductor, in (mm)	2.85 (72.4)
Diameter Inner Conductor, in (mm)	1.14 (29.0)
Nominal Inside Transverse Dimensions, (cm)	6.35
Minimum Bending Radius, in (mm)	30 (760)
Number of Bends, minimum (typical)	15 (25)
Bending Moment, lb-ft (N·m)	30 (41)
Cable Weight, lb/ft (kg/m)	1.78 (2.6)
Tensile Strength, lb (kg)	750 (340)
Flat Plate Crush Strength, lb/in (kg/mm)	175 (3.1)

Attenuation and Average Power Ratings

Frequency MHz	Attenuation dB/100 ft	Attenuation dB/100 m	Average Power, kW
0.5	0.0089	0.0291	640
1	0.0126	0.0414	476
1.5	0.0155	0.0508	387
2	0.0179	0.0588	334
10	0.0410	0.135	146
20	0.0590	0.194	102
30	0.0732	0.240	81.9
50	0.0964	0.316	62.2
88	0.132	0.432	45.6
100	0.141	0.464	42.4
	0.136*	0.448*	33.4*
108	0.148	0.484	40.6
150	0.178	0.583	33.7
174	0.194	0.635	31.0
200	0.210	0.688	28.6
300	0.266	0.874	22.5
400	0.317	1.04	18.9
450	0.340	1.12	17.6
	0.309*	1.01*	14.7*
500	0.363	1.19	16.5
512	0.368	1.21	16.3
600	0.407	1.33	14.7
700	0.448	1.47	13.4
800	0.488	1.60	12.3
	0.429*	1.41*	10.6*
824	0.497	1.63	12.1
894	0.524	1.72	11.4
960	0.548	1.80	10.9
1000	0.563	1.85	10.6
1250	0.652	2.14	9.19
1500	0.737	2.42	8.14
1640	0.782	2.57	7.66

Standard Conditions:

For Attenuation, VSWR 1.0 ambient temperature 20°C (68°F), atmospheric pressure, dry air.

For Average Power, VSWR 1.0, inner temperature 121°C (250°F), ambient temperature 40°C (104°F), atmospheric pressure, dry air, no solar loading.

* These values are for 27591-6 cable with polyethylene dielectric available on special order.

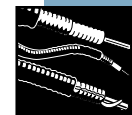

3-1/8" EIA Flange
H8MP-302



1-5/8" EIA Flange
78AS

Connectors

Interface	Description	Type Number	Inner Contact Attachment	Outer Contact Attachment	Plating Code	Max. Length in (mm)	Max. Dia. in (mm)
3-1/8" EIA Flange	Gas pass, includes inner connector	H8MP-302	Tab Flare	Tab Flare	BB	8.06 (204.7)	5.19 (131.7)
3-1/8" EIA Flange	Gas block, includes inner connector**	H8MB-302	Tab Flare	Tab Flare	BB	8.06 (204.7)	5.19 (131.7)
3-1/8" EIA Flange	Gas pass, no inner connector	H8FP-302	Tab Flare	Tab Flare	BB	6.0 (152.4)	5.19 (131.7)
3-1/8" EIA Flange	Gas block, no inner connector	H8FB-302	Tab Flare	Tab Flare	BB	6.0 (152.4)	5.19 (131.7)
1-5/8" EIA Flange	Gas Pass, inner connector	78AS	Tab Flare	Tab Flare	BB	3.9 (99)	3.6 (91)
Splice	-	78BZ	Tab Flare	Tab Flare	BB	6.1 (155)	5.3 (135)

Plating Codes: BB - Brass Body and Pin ** Universal application - designed so that all connector variations of same flange size can be accommodated by modifying this connector, using instructions provided.

Connector Accessories

	Type Number
Connector Reattachment Kit	
For H8MP-302, H8MB-302, H8FP-302, H8FB-302	34767A-60
For 78AGF, 78ARM, 78ARF, 78AGM, 78AS	34767A-10
For 78BZ	34767A-30
3-1/8" EIA End Terminal, for strap connection to center conductor, includes inner connector. Use with H8FP-302.	2062
3-1/8" Inner Connector, with anchor bead	ACX350-20
1-5/8" Inner Conductor, with anchor bead	34660
3-1/8" EIA 90° Miter Elbow, includes one inner connector	ACX350-10SE
1-5/8" EIA 90° Miter Elbow	ACX150-10SE
1-5/8" Gas Barrier	1261B

Accessories

Description	Type No.	
Hangers – For more hangers, adapters and mounting hardware see pages 599-607.		
Standard Hangers Kit of 10. Standard tower configuration spacing is 3-4 feet (1-1.2m). For different spacing recommendations, refer to Cable Hanger Spacing, pages 593-598.	31766A-11	
Hardware Kit of 10. 3/8" bolts, lock washers, nuts		
3/4" (19 mm) long	31769-5	
1" (25 mm) long	31769-1	
Standard Hoisting Grip	26895A	
Grounding and Surge Protection – for additional grounding kits and our surge protection offerings, see pages 609-616.		
Grounding Kit with standard weatherproofing		
Factory attached one-hole lug, 600 mm (24") lead	204989-5	
Field attached screw-on lug, 915 mm (36") lead	204989-35	
Weatherproofing – for additional weatherproofing information see pages 617, 618.		
Connector/Splice Weatherproofing Kit	221213	
Entry Systems – For entry systems offerings see pages 619, 620.		
Standard Cable Entry Boots	4" Boots	5" Boots
One Hole:	204679A-9	48939A-10



4" Air Dielectric, HJ Series – 50-ohm

HJ11-50

Description	Type No.
Cable Ordering Information	
Standard Cable	
4" Standard Cable, Standard Jacket	HJ11-50
Low VSWR and Specialized Cables	
Broadcast, Low VSWR	
54-216 MHz, 1.05 VSWR, max. over broadcast channel	
470-740 MHz, 1.08 VSWR, max. over broadcast channel	
740-856 MHz, 1.10 VSWR, max. over broadcast channel	42144*
* For broadcast applications, specify channel and frequency.	
Characteristics	
Electrical	
Impedance, ohms	50 ± 0.5
Maximum Frequency, GHz	1.22
Velocity, percent	92
Peak Power Rating, kW	1100
dc Resistance, ohms/1000 ft (1000 m)	
Inner	0.11 (0.36)
Outer	0.04 (0.13)
dc Breakdown, volts	21000
Jacket Spark, volts RMS	10000
Capacitance, pF/ft (m)	22.0 (72.2)
Inductance, μH/ft (m)	0.055 (0.18)
Mechanical	
Outer Conductor	Copper
Inner Conductor	Copper
Diameter over Jacket, in (mm)	4.00 (102)
Diameter over Copper Outer Conductor, in (mm)	3.84 (97)
Diameter Inner Conductor, in (mm)	1.55 (39.4)
Nominal Inside Transverse Dimensions, (cm)	8.55
Minimum Bending Radius, in (mm)	40 (1015)
Number of Bends, minimum (typical)	15 (30)
Bending Moment, lb-ft (N·m)	191 (259)
Cable Weight, lb/ft (kg/m)	2.50 (3.72)
Tensile Strength, lb (kg)	900 (408)
Flat Plate Crush Strength, lb/in (kg/mm)	280 (5.0)

Attenuation and Average Power Ratings

Frequency MHz	Attenuation dB/100 ft	Attenuation dB/100 m	Average Power, kW
0.5	0.0074	0.0243	1000
1	0.0105	0.0345	705
1.5	0.0129	0.0423	574.
2	0.0149	0.0489	496
10	0.0339	0.111	218
20	0.0486	0.159	152
30	0.0601	0.197	123
50	0.0788	0.258	94.0
88	0.107	0.350	69.3
100	0.114	0.376	64.7
108	0.119	0.392	62.0
150	0.143	0.469	51.7
174	0.155	0.510	47.6
200	0.168	0.551	44.0
300	0.212	0.694	35.0
400	0.250	0.820	29.6
450	0.268	0.879	27.6
500	0.285	0.935	26.0
512	0.289	0.948	25.6
600	0.318	1.04	23.3
700	0.349	1.14	21.2
800	0.378	1.24	19.6
824	0.385	1.26	19.2
894	0.405	1.33	18.3
960	0.423	1.39	17.5
1000	0.434	1.42	17.1

Standard Conditions:

For Attenuation, VSWR 1.0 ambient temperature 20°C (68°F), atmospheric pressure, dry air.

For Average Power, VSWR 1.0, inner temperature 121°C (250°F), ambient temperature 40°C (104°F), atmospheric pressure, dry air, no solar loading.



6-1/8" EIA Flange
H11FP-602



3-1/8" EIA Flange
H11FB-302

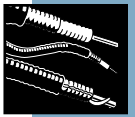

Connectors

Interface	Description	Type Number	Inner Contact Attachment	Outer Contact Attachment	Plating Code	Max. Length in (mm)	Max. Dia. in (mm)
6-1/8" EIA Flange	Gas pass, includes inner connector	H11MP-602	Tab Flare	Tab Flare	BB	11.3 (288)	8.13 (207)
6-1/8" EIA Flange	Gas block, includes inner connector**	H11MB-602	Tab Flare	Tab Flare	BB	11.3 (288)	8.13 (207)
6-1/8" EIA Flange	Gas pass, no inner connector	H11FP-602	Tab Flare	Tab Flare	BB	8.5 (216)	8.13 (207)
6-1/8" EIA Flange	Gas block, no inner connector	H11FB-602	Tab Flare	Tab Flare	BB	8.5 (216)	8.13 (207)
4-1/2" IEC Flange	Gas pass, includes inner connector	H11MP-M408	Tab Flare	Tab Flare	BB	9.4 (240)	6.36 (162)
4-1/2" IEC Flange	Gas block, includes inner connector**	H11MB-M408	Tab Flare	Tab Flare	BB	9.4 (240)	6.36 (162)
4-1/2" IEC Flange	Gas pass, no inner connector	H11FP-M408	Tab Flare	Tab Flare	BB	7.0 (178)	6.36 (162)
4-1/2" IEC Flange	Gas block, no inner connector	H11FB-M408	Tab Flare	Tab Flare	BB	7.0 (178)	6.36 (162)
3-1/8" EIA Flange	Gas pass, includes inner connector	H11MP-302	Tab Flare	Tab Flare	BB	9.1 (230)	5.2 (132)
3-1/8" EIA Flange	Gas block, includes inner connector**	H11MB-302	Tab Flare	Tab Flare	BB	9.1 (230)	5.2 (132)
3-1/8" EIA Flange	Gas pass, no inner connector	H11FP-302	Tab Flare	Tab Flare	BB	7.0 (178)	5.2 (132)
3-1/8" EIA Flange	Gas block, no inner connector	H11FB-302	Tab Flare	Tab Flare	BB	7.0 (178)	5.2 (132)
Splice		81Z	Tab Flare	Tab Flare	BB	7.0 (178)	6.0 (152)

Plating Codes: BB - Brass Body and Pin ** Universal application - designed so that all connector variations of same flange size can be accommodated by modifying this connector, using instructions provided.

Connector Accessories

	Type Number
Connector Reattachment Kit	
For H11(-)-602	34767A-57
For H11(-)-M408	34767A-58
For H11(-)-302	34767A-59
For 81RF	34767A-15
For 81GF	34767A-16
For 42826	34767A-40
For 42896	34767A-41
For 81Z	34767A-17
3-1/8" End Terminal, for strap connection to center conductor, includes inner connector. Use with H11FB-302.	2062
6-1/8" End Terminal, for strap connection to center conductor, includes inner connector. Use with H11FB-602.	RLA650-80
6-1/8" EIA Inner Connector, with anchor bead	ACX650-20
3-1/8" EIA Inner Connector, with anchor bead	ACX350-20
4-1/2" IEC Inner Connector, with anchor bead	241252
3-1/8" EIA 90° Mitre Elbow, includes one inner connector	ACX350-10SE
Reducer, 3-1/8" to 1-5/8", captivated 3-1/8" inner connector	1861
6-1/8" EIA 90° Miter Elbow, includes one inner connector	ACX650B-10SE

Accessories

Description	Type No.
Hangers – For more hangers, adapters and mounting hardware see pages 599-607.	
Standard Hangers Kit of 10. Standard tower configuration spacing is 3-4 feet (1-1.2m). For different spacing recommendations, refer to Cable Hanger Spacing, pages 593-598.	31766A-10
Hardware Kit of 10. 3/8" bolts, lock washers, nuts	
3/4" (19 mm) long	31769-5
1" (25 mm) long	31769-1
Standard Hoisting Grip	34759
Grounding and Surge Protection – for additional grounding kits and our surge protection offerings, see pages 609-616.	
Grounding Kit with standard weatherproofing	
Factory attached one-hole lug, 600 mm (24") lead	204989-6
Field attached screw-on lug, 915 mm (36") lead	204989-36
Weatherproofing – for additional weatherproofing information see pages 617, 618.	
Connector/Splice Weatherproofing Kit	221213

Entry Systems – For entry systems offerings see pages 619, 620.



5" Air Dielectric, HJ Series – 50-ohm

HJ9-50

Description	Type No.
Cable Ordering Information	
Standard Cable	
5" Standard Cable, Standard Jacket	HJ9-50
Low VSWR and Specialized Cables	
Broadcast, Low VSWR	
54-216 MHz, 1.05 VSWR, max. over broadcast channel	
470-740 MHz, 1.08 VSWR, max. over broadcast channel	
740-856 MHz, 1.10 VSWR, max. over broadcast channel	42142*
* For broadcast applications, specify channel and frequency.	
Characteristics	
Electrical	
Impedance, ohms	50 ± 0.5
Maximum Frequency, GHz	0.96
Velocity, percent	93.1
Peak Power Rating, kW	1890
dc Resistance, ohms/1000 ft (1000 m)	
Inner	0.1 (0.3)
Outer	0.04 (0.13)
dc Breakdown, volts	27500
Jacket Spark, volts RMS	12000
Capacitance, pF/ft (m)	21.7 (71.2)
Inductance, μH/ft (m)	0.055 (0.18)
Mechanical	
Outer Conductor	Copper
Inner Conductor	Copper
Diameter over Jacket, in (mm)	5.20 (133)
Diameter over Copper Outer Conductor, in (mm)	5.00 (127)
Diameter Inner Conductor, in (mm)	2.02 (51.3)
Nominal Inside Transverse Dimensions, (cm)	11.3
Minimum Bending Radius, in (mm)	50 (1270)
Number of Bends, minimum (typical)	15 (30)
Bending Moment, lb-ft (N·m)	200 (271)
Cable Weight, lb/ft (kg/m)	3.3 (4.9)
Tensile Strength, lb (kg)	1000 (454)
Flat Plate Crush Strength, lb/in (kg/mm)	275 (4.9)

Attenuation and Average Power Ratings

Frequency MHz	Attenuation dB/100 ft	Attenuation dB/100 m	Average Power, kW
0.5	0.0052	0.0172	1272
1	0.0074	0.0244	898
1.5	0.0091	0.0299	732
2	0.0105	0.0346	633
10	0.0238	0.0782	280
20	0.0340	0.112	196
30	0.0419	0.138	159
50	0.0547	0.180	122
88	0.0738	0.242	90.4
100	0.0789	0.259	84.5
108	0.0822	0.270	81.1
150	0.0981	0.322	68.0
174	0.106	0.349	62.7
200	0.115	0.376	58.1
300	0.143	0.470	46.5
400	0.168	0.552	39.6
450	0.180	0.590	37.1
500	0.191	0.626	34.9
512	0.193	0.635	34.5
600	0.212	0.695	31.5
700	0.231	0.760	28.8
800	0.250	0.821	26.6
824	0.255	0.835	26.2
894	0.267	0.876	25.0
960	0.278	0.913	23.9

Standard Conditions:

For Attenuation. VSWR 1.0 ambient temperature 20°C (68°F), atmospheric pressure, dry air.

For Average Power, VSWR 1.0, inner temperature 100°C (212°F), ambient temperature 40°C (104°F), atmospheric pressure, dry air, no solar loading.

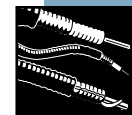

6-1/8" EIA Flange
H9FP-602

Connectors

Interface	Description	Type Number	Inner Contact Attachment	Outer Contact Attachment	Plating Code	Max. Length in (mm)	Max. Dia. in (mm)
6-1/8" EIA Flange	Gas pass, includes inner connector	H9MP-602	Tab Flare	Tab Flare	BB	12.3 (313)	8.13 (207)
6-1/8" EIA Flange	Gas block, includes inner connector**	H9MB-602	Tab Flare	Tab Flare	BB	12.3 (313)	8.13 (207)
6-1/8" EIA Flange	Gas pass, no inner connector	H9FP-602	Tab Flare	Tab Flare	BB	9.5 (241)	8.13 (207)
6-1/8" EIA Flange	Gas block, no inner connector	H9FB-602	Tab Flare	Tab Flare	BB	9.5 (241)	8.13 (207)
4-1/2" IEC Flange	Gas pass, includes inner connector	H9MP-M408	Tab Flare	Tab Flare	BB	10.7 (272)	6.6 (168)
4-1/2" IEC Flange	Gas block, includes inner connector**	H9MB-M408	Tab Flare	Tab Flare	BB	10.7 (272)	6.6 (168)
4-1/2" IEC Flange	Gas pass, no inner connector	H9FP-M408	Tab Flare	Tab Flare	BB	8.3 (211)	6.6 (168)
4-1/2" IEC Flange	Gas block, no inner connector	H9FB-M408	Tab Flare	Tab Flare	BB	8.3 (211)	6.6 (168)
Splice	-	79AZ	Tab Flare	Tab Flare	BB	6.2 (157)	7.6 (193)

Plating Codes: BB - Brass Body and Pin ** Universal application - designed so that all connector variations of same flange size can be accommodated by modifying this connector, using instructions provided.

Connector Accessories

	Type Number
Connector Reattachment Kit	
For 79AG, 79AR	34767A-45
For H9(-)-602	34767A-55
For H9(-)-M408	34767A-56
For 79AZ	34767A-31
6-1/8" End Terminal, for strap connection to center conductor, includes inner connector. Use with H9FB-602.	RLA650-80
6-1/8" EIA Inner Connector, with anchor bead	ACX650-20
4-1/2" IEC Inner Connector, with anchor bead	241252
Reducer, 6-1/8" to 3-1/8" includes two inner connectors	RLA650-350
6-1/8" EIA 90° Miter Elbow, includes one inner connector	ACX650-10SE

Accessories

Description	Type No.
Hangers – For more hangers, adapters and mounting hardware see pages 599-607.	
Standard Hangers Kit of 10. Standard tower configuration spacing is 3-4 feet (1-1.2m). For different spacing recommendations, refer to Cable Hanger Spacing, pages 593-598.	33598-5
Hardware Kit of 10. 1/2" x 1-1/4" bolts, lock washers, nuts	31769-4
Standard Hoisting Grip	31031-1
Grounding and Surge Protection – for additional grounding kits and our surge protection offerings, see pages 609-616.	
Grounding Kit with standard weatherproofing	
Factory attached one-hole lug, 600 mm (24") lead	204989-7
Field attached screw-on lug, 915 mm (36") lead	204989-37
Weatherproofing – for additional weatherproofing information see pages 617, 618.	
Connector/Splice Weatherproofing Kit	221213

Entry Systems – For entry systems offerings see pages 619, 620.



5" Air Dielectric, High Power HJ()HP Series – 50-ohm

HJ9HP-50

Description	Type No.
Cable Ordering Information	
High Power Cable	
5" Standard High Power Cable	HJ9HP-50
45 – 70 MHz, 1.06 VSWR, max.	
87 – 108 MHz, 1.06 VSWR, max. over broadcast channel	
170 – 230 MHz, 1.08 VSWR, max. over broadcast channel	
470 – 860 MHz, 1.10 VSWR, max. over broadcast channel	
* For broadcast applications, specify channel and frequency.	
Characteristics	
Electrical	
Impedance, ohms	50 ± 0.5
Maximum Frequency, GHz	0.96
Velocity, percent	96.4
Peak Power Rating, kW	1690
dc Resistance, ohms/1000 ft (1000 m)	
Inner	0.1 (0.33)
Outer	0.04 (0.13)
dc Breakdown, volts	26000
Jacket Spark, volts RMS	12000
Capacitance, pF/ft (m)	20.8 (68.1)
Inductance, µH/ft (m)	0.054 (0.176)
Mechanical	
Outer Conductor	Copper
Inner Conductor	Copper
Diameter over Jacket, in (mm)	5.20 (132)
Diameter over Outer Conductor, in (mm)	5.00 (127)
Diameter Inner Conductor, in (mm)	2.07 (52.7)
Nominal Inside Transverse Dimensions, (cm)	11.3
Minimum Bending Radius, in (mm)	50 (1270)
Number of Bends, minimum (typical)	15 (30)
Bending Moment, lb-ft (N·m)	200 (271)
Cable Weight, lb/ft (kg/m)	3.4 (4.9)
Tensile Strength, lb (kg)	1000 (454)
Flate Plate Crush Strength, lb/in (kg/mm)	240 (4.29)

Attenuation and Average Power Ratings

Frequency MHz	Attenuation dB/100 ft	Attenuation dB/100 m	Average Power, kW
0.5	0.0045	0.0148	1690
1	0.0064	0.0211	1690
1.6	0.0081	0.0267	1540
2	0.0092	0.0300	1375
10	0.0211	0.0693	599
20	0.0306	0.100	416
30	0.0381	0.125	335
50	0.0505	0.166	254
88	0.0695	0.228	185
100	0.0748	0.245	172
108	0.0782	0.257	165
150	0.0948	0.311	137
174	0.104	0.340	125
200	0.113	0.369	116
300	0.144	0.474	90.8
400	0.173	0.568	76.2
450	0.186	0.612	70.8
500	0.200	0.655	66.3
512	0.203	0.665	65.3
600	0.225	0.737	59.1
700	0.249	0.816	53.6
800	0.272	0.893	49.1
824	0.278	0.910	48.2
860	0.286	0.937	48.9
894	0.293	0.962	45.7
960	0.308	1.010	43.6

Standard Conditions:

For Attenuation. VSWR 1.0 ambient temperature 20°C (68°F), atmospheric pressure, dry air.

For Average Power, VSWR 1.0, inner temperature 150°C (302°F), ambient temperature 40°C (104°F), atmospheric pressure, dry air, no solar loading.

United States Patent No. 5,742,002

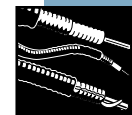

6-1/8" EIA Flange
H9HPFP-602

Connectors

Interface	Description	Type Number	Inner Contact Attachment	Outer Contact Attachment	Plating Code	Max. Length in (mm)	Max. Dia. in (mm)
6-1/8" EIA Flange	Gas pass, includes inner connector	H9HPMP-602	Tab Flare	Tab Flare	BB	12.4 (315)	8.13 (207)
6-1/8" EIA Flange	Gas block, includes inner connector**	H9HPMB-602	Tab Flare	Tab Flare	BB	12.4 (315)	8.13 (207)
6-1/8" EIA Flange	Gas pass, no inner connector	H9HPFP-602	Tab Flare	Tab Flare	BB	9.5 (242)	8.13 (207)
6-1/8" EIA Flange	Gas block, no inner connector	H9HPFB-602	Tab Flare	Tab Flare	BB	9.5 (242)	8.13 (207)
Splice	–	H9HPZ	Tab Flare	Tab Flare	BB	6.19 (158)	7.57 (193)

Plating Codes: BB - Brass Body and Pin ** Universal application - designed so that all connector variations of same flange size can be accommodated by modifying this connector, using instructions provided.

Connector Accessories

	Type Number
Connector Reattachment Kit	
For H9 () HP-602	34767A-55
For H9HPZ	34767A-31
6-1/8" End Terminal, for strap connection to center conductor, includes inner connector. Use with H9HPFB-602.	RLA650-80
6-1/8" EIA Inner Connector, with anchor bead	ACX650-20
4-1/2" IEC Inner Connector, with anchor bead	241252
Reducer, 6-1/8" to 3-1/8" includes two inner connectors	RLA650-350
6-1/8" EIA 90° Miter Elbow, includes one inner connector	ACX650B-10SE

Accessories

Description	Type No.
Hangers – For more hangers, adapters and mounting hardware see pages 599-607.	
Standard Hangers Kit of 10. Standard tower configuration spacing is 3-4 feet (1-1.2m). For different spacing recommendations, refer to Cable Hanger Spacing, pages 593-598.	33598-5
Hardware Kit of 10. 1/2" x 1-1/4" bolts, lock washers, nuts	31769-4
Standard Hoisting Grip	31031-1
Grounding and Surge Protection – for additional grounding kits and our surge protection offerings, see pages 609-616.	
Grounding Kit with standard weatherproofing	
Factory attached one-hole lug, 600 mm (24") lead	204989-7
Field attached screw-on lug, 915 mm (36") lead	204989-37
Weatherproofing – for additional weatherproofing information see pages 617, 618.	
Connector/Splice Weatherproofing Kit	221213

Entry Systems – For entry systems offerings see pages 619, 620.

1/4" Superflexible Foam Dielectric, FSJ Series – 75-ohm

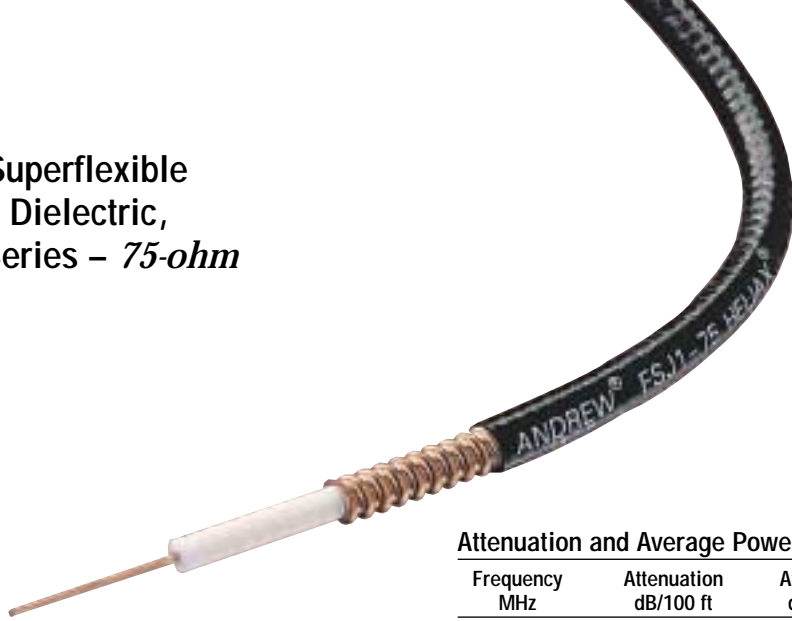

FSJ1-75

Description	Type No.
Cable Ordering Information	
Standard Cable	
1/4" Standard superflexible	FSJ1-75
Fire Retardant Cables	
1/4" Fire Retardant Jacket (CATVX)	FSJ1RN-75A
1/4" Fire Retardant Jacket (CATVR)	FSJ1RN-75A

Characteristics

Electrical	
Impedance, ohms	75 ± 3
Maximum Frequency, GHz	22.0
Velocity, percent	78
Peak Power Rating, kW	6.7
dc Resistance, ohms/1000 ft (1000 m)	
Inner	15 (49.2)
Outer	1.8 (5.9)
dc Breakdown, volts	2000
Jacket Spark, volts RMS	5000
Capacitance, pF/ft (m)	17.4 (57.0)
Inductance, µH/ft (m)	0.098 (0.321)
Mechanical	
Outer Conductor	Copper
Inner Conductor	Copper-Clad Steel
Diameter over Jacket, in (mm)	0.29 (7.4)
Diameter over Copper Outer Conductor, in (mm)	0.25 (6.4)
Minimum Bending Radius, in (mm)	1 (25)
Number of Bends, minimum (typical)	15 (50)
Bending Moment, lb-ft (N·m)	0.5 (0.68)
Cable Weight, lb/ft. (kg/m)	0.046 (0.068)
Tensile Strength, lb (kg)	150 (68)
Flat Plate Crush Strength, lb/in (kg/mm)	100 (1.8)

Attenuation and Average Power Ratings

Frequency MHz	Attenuation dB/100 ft	Attenuation dB/100 m	Average Power, kW
0.5	0.126	0.413	8.43
1	0.178	0.585	5.95
1.5	0.219	0.718	4.85
2	0.253	0.830	4.20
10	0.570	1.87	1.86
20	0.812	2.66	1.31
30	0.999	3.28	1.06
50	1.30	4.27	0.817
88	1.74	5.72	0.609
100	1.86	6.12	0.570
108	1.94	6.37	0.547
150	2.31	7.57	0.460
174	2.50	8.19	0.425
200	2.69	8.82	0.395
300	3.34	11.0	0.318
400	3.91	12.8	0.272
450	4.17	13.7	0.255
500	4.42	14.5	0.241
512	4.48	14.7	0.237
600	4.89	16.0	0.217
700	5.32	17.5	0.200
800	5.74	18.8	0.185
824	5.83	19.1	0.182
894	6.11	20.0	0.174
960	6.36	20.9	0.167
1000	6.51	21.4	0.163
1250	7.40	24.3	0.144
1500	8.22	27.0	0.129
1700	8.84	29.0	0.120
1800	9.14	30.0	0.116
2000	9.73	31.9	0.109
2100	10.0	32.9	0.106
2200	10.3	33.8	0.103
2300	10.6	34.7	0.101
3000	12.4	40.7	0.086
3300	13.2	43.1	0.081
3400	13.4	43.9	0.079
4000	14.8	48.6	0.072
4900	16.8	55.2	0.063
6000	19.1	62.7	0.056
8000	23.0	75.6	0.046
10000	26.7	87.6	0.040
12000	30.2	99.0	0.035
14000	33.5	110.0	0.032
16000	36.8	120.7	0.029
18000	39.9	131.0	0.027
19000	41.5	136.1	0.026
20000	43.0	141.1	0.025
22000	46.0	151.0	0.023

Standard Conditions:

For Attenuation. VSWR 1.0 ambient temperature 20°C (68°F), atmospheric pressure, dry air.

For Average Power, VSWR 1.0, inner temperature 40°C (104°F), inner conductor temperature 1000°C (212°F), no solar loading.

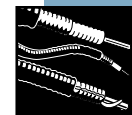

N Male
F1NM-7550

Connectors

Interface	Description	Type Number	Inner Contact Attachment	Outer Contact Attachment	Plating Code	Max. Length in (mm)	Max. Dia. in (mm)
N Male	50 Ohm Mating Pin	F1NM-7550-H	Solder	Solder	SG	1.85 (47)	0.92 (23.4)
N Male	70 Ohm Mating Pin	F1NM-7570	Solder	Solder	NS	2.2 (56)	0.79 (20.1)
N Female	70 Ohm Mating Pin	F1NF-7570	Solder	Solder	BS	1.9 (48)	0.70 (17.8)
BNC Male	50 Ohm Mating Pin	49651	Solder	Tab Flare	BS	1.2 (30)	0.56 (14.2)
UHF Male	50 Ohm Mating Pin	41SP	Solder	Tab Flare	BB	1.5 (38)	0.72 (18.3)
TNC Male	50 Ohm Mating Pin	41SWT-75	Solder	Tab Flare	SS	1.1 (28)	0.63 (16.0)
CATV Type F	-	F1FM-75	Captivated	Crimp	BB	1.42 (36)	0.56 (14.2)

Plating Codes: BB - Brass Body and Pin, BS - Brass Body and Silver Plated Pin, NS - Nickel Plated Body and Silver Plated Pin, SS - Silver Plated Body and Pin, SG - Silver Plated Body and Gold Plated Pin

Accessories

Description	Type No.
Hangers – For more hangers, adapters and mounting hardware see pages 599-607.	
Insulated Hanger , single. Recommended maximum spacing is 2.5 ft (0.76 m). For different spacing recommendations, refer to Cable Hanger Spacing, pages 593-598	11662-3
Angle Adapter , for insulated hanger	40430-1
Nylon Cable Tie Kit of 50, Indoor use, Recommended maximum spacing is 1.5 ft (0.5 m)	40417
Nylon Cable Tie Kit in plastic box. 100 each 4, 5.5 and 7.5 inch ties. Indoor use, Recommended maximum spacing is 1.5 ft (0.5 m)	CT-K350
Velcro Cable Ties , Black, 8 inch. Indoor Use	
Kit of 10	VCT8-10
Kit of 50	VCT8-50
Kit of 100	VCT8-100
Support/Hoisting Grip . Use at 200-ft (60 m) intervals.	
Grip with one clamp	F1SGRIP
Support clamp kit of 10	F1SGRIP-11K
Grounding and Surge Protection – for additional grounding kits and our surge protection offerings, see pages 609-616.	
Standard Grounding Kit	
Factory attached one-hole lug, 24" lead	223158
Factory attached two-hole lug, 24" lead	223158-2
Field attached one-hole lug, 36" lead	223158-3

Description	Type No.
Weatherproofing – for additional weatherproofing information see pages 617, 618.	
Cold Shrink Weatherproofing Kit	
5/8" Coax to 1/4" Coax	241475-13
7/8" Coax to 1/4" Coax	241475-12
1-1/4" or 1-5/8" Coax to 1/4" Coax	241475-11
1/4" to 1-1/2" Omni/Panel base Type N or DIN	241548-10
1/4" to 2" Omni/Panel base Type N or DIN	241548-11
Connector/Splice Weatherproofing Kit	221213
Entry Systems – For entry systems offerings see pages 619, 620.	
Standard Cable Entry Boots	
4" Boots – Three Hole:	204679A-17
Tools – for additional tool offerings see pages 620-623.	
EASIAx® Cutting Tool FSJ1/FSJ4	207865
DIN Connector Coupling Torque Wrench	244377
N Connector Coupling Torque Wrench	244379



1/2" Superflexible Foam Dielectric, FSJ Series – 75-ohm

FSJ4-75A

Description	Type No.
-------------	----------

Cable Ordering Information

Standard Cable	
1/2" Standard Superflexible	FSJ4-75A
Fire Retardant Cables	
1/2" Fire Retardant Jacket (CATVX)	FSJ4RN-75A
1/2" Fire Retardant Jacket (CATVR)	FSJ4RN-75A

Characteristics

Electrical	
Impedance, ohms	75 ± 2
Maximum Frequency, GHz	11.5
Velocity, percent	81
Peak Power Rating, kW	10.0
dc Resistance, ohms/1000 ft (1000 m)	
Inner	1.50 (4.9)
Outer	1.00 (3.28)
dc Breakdown, volts	2500
Jacket Spark, volts RMS	5000
Capacitance, pF/ft (m)	16.7 (54.9)
Inductance, µH/ft (m)	0.094 (0.309)
Mechanical	
Outer Conductor	Copper
Inner Conductor	Copper
Diameter over Jacket, in (mm)	0.52 (13.2)
Diameter over Copper Outer Conductor in (mm)	0.48 (12.2)
Diameter Inner Conductor, in (mm)	0.118 (3.0)
Minimum Bending Radius, in (mm)	1.25 (32)
Number of Bends, minimum (typical)	20 (50)
Bending Moment, lb-ft (N·m)	2.0 (2.7)
Cable Weight, lb/ft (kg/m)	0.14 (0.21)
Tensile Strength, lb (kg)	140 (63.5)
Flat Plate Crush Strength, lb/in (kg/mm)	105 (1.9)

Attenuation and Average Power Ratings

Frequency MHz	Attenuation dB/100 ft	Attenuation dB/100 m	Average Power, kW
0.5	0.065	0.213	26.2
1	0.092	0.301	18.5
1.5	0.112	0.369	15.1
2	0.130	0.427	13.1
10	0.293	0.962	5.79
20	0.417	1.37	4.07
30	0.514	1.68	3.30
50	0.668	2.19	2.54
88	0.896	2.94	1.89
100	0.958	3.14	1.77
108	0.997	3.27	1.70
150	1.19	3.89	1.43
174	1.28	4.21	1.32
200	1.38	4.53	1.23
300	1.72	5.63	0.989
400	2.01	6.58	0.846
450	2.14	7.02	0.794
500	2.27	7.44	0.749
512	2.30	7.53	0.739
600	2.51	8.22	0.677
700	2.73	8.96	0.622
800	2.94	9.65	0.577
824	2.99	9.82	0.568
894	3.13	10.3	0.542
960	3.26	10.7	0.521
1000	3.34	11.0	0.509
1250	3.79	12.4	0.448
1500	4.21	13.8	0.403
1700	4.53	14.9	0.375
1800	4.68	15.4	0.363
2000	4.98	16.4	0.341
2100	5.13	16.8	0.331
2200	5.27	17.3	0.322
2300	5.42	17.8	0.314
3000	6.35	20.8	0.268
3300	6.73	22.1	0.252
3400	6.86	22.5	0.248
4000	7.58	24.9	0.224
4900	8.60	28.2	0.198
6000	9.78	32.1	0.174
8000	11.8	38.6	0.144
10000	13.6	44.7	0.125
11500	15.0	49.1	0.114

Standard Conditions:

For Attenuation, VSWR 1.0 ambient temperature 20°C (68°F), atmospheric pressure, dry air.

For Average Power, VSWR 1.0, ambient temperature 40°C (104°F), inner conductor temperature 100°C (212°F), no solar loading.

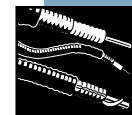

N Male
F4NM-7570



N Female
F4NF-7570

Connectors

Interface	Description	Type Number	Inner Contact Attachment	Outer Contact Attachment	Plating Code	Max. Length in (mm)	Max. Dia. in (mm)
N Male	50 Ohm Mating Pin	F4NM-7550	Solder	Tab Flare	BB	2.3 (58)	0.84 (21.3)
N Male	70 Ohm Mating Pin	F4NM-7570	Solder	Tab Flare	BB	2.2 (56)	0.84 (21.3)
N Male	50 Ohm Mating Pin, Right Angle	F4NR-7550	Solder	Tab Flare	BB	3.3/1.5 (84/38)	0.84 (21.3)
N Female	50 Ohm Mating Pin	F4NF-7550	Solder	Tab Flare	BS	2.2 (56)	0.84 (21.3)
N Female	70 Ohm Mating Pin	F4NF-7570	Solder	Tab Flare	BS	2.1 (53)	0.84 (21.3)
UHF Male	50 Ohm Mating Pin	44ASP-75	Solder	Tab Flare	BS	2.3 (58)	0.84 (21.3)
UHF Female	50 Ohm Mating Pin	44ASU-75	Solder	Tab Flare	BS	2.3 (58)	0.84 (21.3)
CATV Type F	-	44ASCM	Solder	Tab Flare	BB	2.5 (64)	0.84 (21.3)

Plating Codes: BB - Brass Body and Pin, BS - Brass Body and Silver Plated Pin.

Accessories

Description	Type No.
Hangers – For more hangers, adapters and mounting hardware see pages 599-607.	
Standard Hangers Kit of 10. Recommended maximum spacing is 3-ft (1 m). For different spacing recommendations, refer to Cable Hanger Spacing, pages 593-598.	43211A
Snap-In Hangers Kit of 10. For prepunched 3/4" (19mm) holes on tower member or adapters, Recommended maximum spacing is 3-ft (1 m). For different spacing recommendations, refer to Cable Hanger Spacing, pages 593-598.	206706-1
Support/Hoisting Grip. Use at 200-ft (60 m) intervals.	
Grip with one clamp	F4SGRIP
Support clamp kit of 10	F4SGRIP-4IK
Standard Hoisting Grip	43094
Grounding and Surge Protection – for additional grounding kits and our surge protection offerings, see pages 609-616.	
Standard Grounding Kits	
Factory attached one-hole lug 24"	204989-1
Factory attached two-hole lug 24"	241088-1
Field attached two-hole lug 60"	241545

Description	Type No.
Weatherproofing – for additional weatherproofing information see pages 617, 618.	
WeatherShield™ Connector Protection Housing	
LDF5 to FSJ4	WS-L5F4
LDF6 to FSJ4	WS-L6F4
LDF7 to FSJ4	WS-L7F4
Cold Shrink Weatherproofing Kit	
1/2" Coax N Connector to 1/2" Coax N Connector	241474-4
5/8" Coax to 1/2" Coax	241475-13
7/8" Coax to 1/2" Coax	241475-9
1-1/4" or 1-5/8" Coax to 1/2" Coax	241475-5A
2 1/4" Coax to 1/2" Coax	241475-8
1/2" to 1-1/2" Omni/Panel Base Type N or DIN	241548-8
Connector/Splice Weatherproofing Kit	221213
Entry Systems – For entry systems offerings see pages 619, 620.	
Standard Cable Entry Boots	4" Boots 5" Boots
One Hole:	204679A-5 48939A-6
Three Hole:	204679A-7 48939A-8
Four Hole	204679A-16 48939A-17
Tools – for additional tool offerings see pages 620-623.	
EASIAx® Plus Automated Cable Prep Tool	CPT-F4B
EASIAx® Cutting Tool FSJ4/FSJ1	207865
EASIAx® Cutting Tool FSJ4/FSJ2	241372
Cable Flare Tool	224363
DIN Connector Coupling Torque Wrench	244377
N Connector Coupling Torque Wrench	244379



1/2" Foam Dielectric, LDF Series – 75-ohm



LDF4-75A

Description	Type No.
Cable Ordering Information	
Standard Cable	
1/2" Standard superflexible	LDF4-75A
Fire Retardant Cables	
1/2" Fire Retardant Jacket (CATVX)	LDF4RN-75A
1/2" Fire Retardant Jacket (CATVR)	LDF4RN-75A

Characteristics

Electrical	
Impedance, ohms	75 ± 3
Maximum Frequency, GHz	10
Velocity, percent	88
Peak Power Rating, kW	26
dc Resistance, ohms/1000 ft (1000 m)	
Inner	1.15 (3.77)
Outer	0.58 (1.90)
dc Breakdown, volts	4000
Jacket Spark, volts RMS	8000
Capacitance, pF/ft (m)	15.4 (50.5)
Inductance, µH/ft (m)	0.087 (0.284)
Mechanical	
Outer Conductor	Copper
Inner Conductor	Copper-Clad Aluminum
Diameter over Jacket, in (mm)	0.63 (16)
Diameter over Copper Outer Conductor, in (mm)	0.55 (14)
Minimum Bending Radius, in (mm)	5 (125)
Number of Bends, minimum (typical)	15 (40)
Bending Moment, lb-ft (N·m)	2.8 (3.8)
Cable Weight, lb/ft (kg/m)	0.14 (0.21)
Tensile Strength, lb (kg)	200 (90.7)
Flat Plate Crush Strength, lb/in (kg/mm)	110 (2.0)

Attenuation and Average Power Ratings

Frequency MHz	Attenuation dB/100 ft	Attenuation dB/100 m	Average Power, kW
0.5	0.042	0.138	24.5
1	0.060	0.196	17.3
1.5	0.073	0.240	14.1
2	0.084	0.277	12.2
10	0.190	0.624	5.43
20	0.270	0.887	3.82
30	0.333	1.09	3.10
50	0.432	1.42	2.39
88	0.579	1.90	1.78
100	0.618	2.03	1.67
108	0.644	2.11	1.60
150	0.764	2.51	1.35
174	0.826	2.71	1.25
200	0.889	2.92	1.16
300	1.10	3.62	0.937
400	1.29	4.22	0.803
450	1.37	4.50	0.753
500	1.45	4.76	0.712
512	1.47	4.82	0.702
600	1.60	5.26	0.644
700	1.74	5.72	0.592
800	1.88	6.16	0.550
824	1.91	6.26	0.541
894	2.00	6.55	0.517
960	2.08	6.81	0.497
1000	2.12	6.97	0.486
1250	2.41	7.90	0.429
1500	2.67	8.76	0.387
1700	2.87	9.41	0.360
1800	2.96	9.73	0.348
2000	3.15	10.3	0.328
2100	3.24	10.6	0.319
2200	3.33	10.9	0.310
2300	3.42	11.2	0.302
2500	3.59	11.8	0.288
3300	4.23	13.9	0.244
3400	4.30	14.1	0.240
4000	4.75	15.6	0.218
4900	5.37	17.6	0.192
6000	6.09	20.0	0.170
8000	7.29	23.9	0.142
10000	8.42	27.6	0.123

Standard Conditions:

For Attenuation, VSWR 1.0 ambient temperature 20°C (68°F).

For Average Power, VSWR 1.0, ambient temperature 40°C (104°F), inner conductor temperature 100°C (212°F), no solar loading.



N Male
L4NM-7570



N Female
L4NF-7570

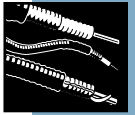

Connectors

Interface	Description	Type Number	Inner Contact Attachment	Outer Contact Attachment	Plating Code	Max. Length in (mm)	Max. Dia. in (mm)
N Male	50 Ohm Mating Pin	L4NM-7550-H	Solder	Self Flare	BB	2.5 (64)	0.94 (23.8)
N Male	70 Ohm Mating Pin	L4NM-7570-H	Solder	Self Flare	BB	2.5 (64)	0.94 (23.8)
N Male	50 Ohm Mating Pin, Right Angle	L4NR-7550	Solder	Self Flare	NB	3.2/1.5 (81/38)	0.95 (24.1)
N Female	50 Ohm Mating Pin	L4NF-7550	Solder	Self Flare	BB	2.5 (64)	0.91 (23.1)
N Female	70 Ohm Mating Pin	L4NF-7570	Solder	Self Flare	BB	2.3 (58)	0.91 (23.1)
UHF Male	-	L44P-75	Solder	Self Flare	BB	2.3 (58)	0.91 (23.1)
UHF Female	-	L44U-75	Solder	Self Flare	BB	2.3 (58)	0.91 (23.1)
CATV Equipment Housing Splice	-	48070	-	Self Flare	BB	2.0 (50)	0.91 (23.1)
		L44Z-75	Solder	Self Flare	BB	3.2 (81)	1.1 (27.9)

Plating Codes: BB - Brass Body and Pin, NB - Nickel Plated Body and Brass Pin.

Accessories

Description	Type No.
Hangers – For more hangers, adapters and mounting hardware see pages 599-607.	
Standard Hangers Kit of 10. Recommended maximum spacing is 3-ft (1 m). For different spacing recommendations, refer to Cable Hanger Spacing, pages 593-598.	43211A
Hardware Kit of 10. 3/8" bolts, lockwashers, nuts	
3/4" (19 mm) long	31769-5
1" (25 mm) long	31769-1
Snap-In Hangers Kit of 10. For prepunched 3/4" (19mm) holes on tower member or adapters, Recommended maximum spacing is 3-ft. For different spacing recommendations, refer to Cable Hanger Spacing, pages 593-598.	206706-1
Click-On Hangers Kit of 10. Recommended maximum spacing is 3-ft	L4CLICK
Mounting Hardware see page 605.	
Kwik-Clamps Kit of 10. See page 607 for hanger options	
Support/Hoisting Grip . Use at 200-ft (60m) intervals.	
Grip with one clamp	L4SGRIP
Support clamp kit of 10	L4SGRIP-4IK
Standard Hoisting Grip	43094
Grounding and Surge Protection – for additional grounding kits and our surge protection offerings, see pages 609-616.	
SureGround Grounding Kit with standard weatherproofing	
Factory attached one-hole lug, 600 mm (24") lead	SGL4-06B1
Factory attached two-hole lug, 600 mm (24") lead	SGL4-06B2
Field attached two-hole lug, 1500 mm (59") lead	SGL4-15B4

Description	Type No.	
SureGround Plus Grounding Kit with weatherproofing boot		
Factory attached one-hole lug, 600 mm (24") lead	SGPL4-06B1	
Factory attached two-hole lug, 600 mm (24") lead	SGPL4-06B2	
Field attached two-hole lug, 1500 mm (59") lead	SGPL4-15B4	
Weatherproofing – for additional weatherproofing information see pages 617, 618.		
Cold Shrink Weatherproofing Kit		
1/2" Coax N Connector to 1/2" Coax N Connector	241474-4	
5/8" Coax to 1/2" Coax	242475-13	
7/8" Coax to 1/2" Coax	241475-9	
1-1/4" or 1-5/8" Coax to 1/2" Coax	241475-5A	
2 1/4" Coax to 1/2" Coax	241475-8	
1/2" to 1-1/2" Omni/Panel base Type N or DIN	241548-8	
1/2" to 2" Omni/Panel base Type N or DIN	241548-9	
1/2" LDF4 to Antenna Type N interface	241548-4	
Connector/Splice Weatherproofing Kit	221213	
Entry Systems – For entry systems offerings see pages 619, 620.		
Standard Cable Entry Boots	4" Boots	5" Boots
One Hole:	204679A-5	48939A-6
Three Hole:	204679A-7	48939A-8
Four Hole	204679A-16	48939A-17
Tools – for additional tool offerings see pages 620-623.		
EASIAx® Plus Automated Cable Prep Tool	CPT-L4ARC	
EASIAx® Cutting Tool	207866	
Cable Flare Tool	224363	
DIN Connector Coupling Torque Wrench	244377	
N Connector Coupling Torque Wrench	244379	

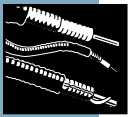

7/8" Foam Dielectric, LDF Series – 75-ohm

LDF5-75

Description	Type No.
Cable Ordering Information	
Standard Cable	
7/8" Standard Cable	LDF5-75
Characteristics	
Electrical	
Impedance, ohms	75 ± 3
Maximum Frequency, GHz	5.3
Velocity, percent	89
Peak Power Rating, kW70	
dc Resistance, ohms/1000 ft (1000 m)	
Inner	0.34 (1.11)
Outer	0.32 (1.05)
dc Breakdown, volts	6500
Jacket Spark, volts RMS	8000
Capacitance, pF/ft (m)	15.1 (49.5)
Inductance, µH/ft (m)	0.087 (0.284)
Mechanical	
Outer Conductor	Copper
Inner Conductor	Copper-clad aluminum
Diameter over Jacket, in (mm)	1.082 (27.48)
Diameter over Copper Outer Conductor, in (mm)	0.980 (24.89)
Minimum Bending Radius, in (mm)	10 (250)
Number of Bends, minimum (typical)	15 (40)
Bending Moment, lb-ft (Nim)	12 (16.3)
Cable Weight, lb/ft (kg/m)	0.30 (0.45)
Tensile Strength, lb (kg)	325 (147)
Flat Plate Crush Strength, lb/in (kg/mm)	80 (1.4)

Attenuation and Average Power Ratings

Frequency MHz	Attenuation dB/100 ft	Attenuation dB/100 m	Average Power, kW
0.5	0.024	0.080	45.2
1	0.034	0.113	31.9
1.5	0.042	0.139	26.0
2	0.049	0.160	22.5
10	0.111	0.363	9.94
20	0.158	0.518	6.96
30	0.195	0.639	5.65
50	0.254	0.833	4.33
88	0.342	1.12	3.21
100	0.366	1.20	3.00
108	0.382	1.25	2.88
150	0.455	1.49	2.42
174	0.493	1.62	2.23
200	0.532	1.75	2.07
300	0.665	2.18	1.65
400	0.781	2.56	1.41
450	0.834	2.74	1.32
500	0.885	2.90	1.24
512	0.897	2.94	1.23
600	0.982	3.22	1.12
700	1.07	3.52	1.03
800	1.16	3.81	0.949
824	1.18	3.87	0.933
894	1.24	4.06	0.889
960	1.29	4.24	0.853
1000	1.32	4.34	0.832
1250	1.51	4.95	0.729
1500	1.69	5.53	0.653
1700	1.82	5.97	0.605
1800	1.88	6.18	0.584
2000	2.01	6.60	0.548
2100	2.07	6.80	0.531
2200	2.13	7.00	0.516
2300	2.19	7.20	0.502
3000	2.59	8.51	0.425
3400	2.81	9.23	0.392
4000	3.12	10.3	0.353
5000	3.62	11.9	0.304
5300	3.76	12.3	0.293

Standard Conditions:

For Attenuation, VSWR 1.0 ambient temperature 20°C (68°F).

For Average Power, VSWR 1.0, ambient temperature 40°C (104°F), inner conductor temperature 100°C (212°F), no solar loading.



N Female
L5PNF-7570-BH

Connectors

Interface	Description	Type Number	Inner Contact Attachment	Outer Contact Attachment	Plating Code	Max. Length in (mm)	Max. Dia. in (mm)
N Male	70-Ohm Mating Pin	L5PNM-7570	Solder	Self-Flare	SG	2.9 (74)	1.36 (34.5)
N Male	50-Ohm Mating Pin	L5PNM-7550	Solder	Self-Flare	SG	3.1 (78.7)	1.36 (34.5)
N Female	70-Ohm Mating Pin	L5PNF-7570	Solder	Self-Flare	SG	2.9 (74)	1.36 (34.5)
N Female	70-Ohm Mating Pin Bulkhead	L5PNF-7570-BH	Solder	Self Flare	BB	3.1 (78.7)	1.36 (34.5)

Plating Codes: BB - Brass Body and Pin, SG - Silver Plated Body and Gold Plated Pin

Accessories

Description	Type No.
Hangers – For more hangers, adapters and mounting hardware see pages 599-607.	
Standard Hangers Kit of 10. Recommended maximum spacing is 3-ft (1 m). For different spacing recommendations, refer to Cable Hanger Spacing, pages 593-598.	42396A-5
Hardware Kit of 10. 3/8" bolts, lockwashers, nuts	
3/4" (19 mm) long	31769-5
1" (25 mm) long	31769-1
Snap-in Hangers Kit of 10. For prepunched 3/4" (19 mm) holes on tower member or adapters. Recommended maximum spacing is 3-ft. For different spacing recommendations, refer to Cable Hanger Spacing, pages 593-598.	206706-2
Click-On Hangers Kit of 10. Recommended maximum spacing is 3-ft	L5CLICK
Mounting Hardware see page 605.	
Kwik-Clamps Kit of 10. See page 607 for hanger options	
Support/Hoisting Grip. Use at 200-ft (60m) intervals.	
Grip with one clamp	L5SGRIP
Support clamp kit of 10	L5SGRIP-5IK
Standard Hoisting Grip	19256B
Grounding and Surge Protection – for additional grounding kits and our surge protection offerings, see pages 609-616.	
SureGround Grounding Kit with standard weatherproofing	
Factory attached one-hole lug, 600 mm (24") lead	SGL5-06B1
Factory attached two-hole lug, 600 mm (24") lead	SGL5-06B2
Field attached two-hole lug, 1500 mm (59") lead	SGL5-15B4
SureGround Plus Grounding Kit with weatherproofing boot	
Factory attached one-hole lug, 600 mm (24") lead	SGPL5-06B1
Factory attached two-hole lug, 600 mm (24") lead	SGPL5-06B2
Field attached two-hole lug, 1500 mm (59") lead	SGPL5-15B4

Description	Type No.	
Weatherproofing – for additional weatherproofing information see pages 617-618.		
WeatherShield™ Connector Protection Housing		
LDF5 to LDF4	WS-L5L4	
LDF5 to FSJ4	WS-L5F4	
Cold Shrink Weatherproofing Kit		
7/8" Coax to 7/8" Coax N Connectors	241474-5	
1-5/8" Coax to 7/8" Coax N Connectors	241475-3	
7/8" Coax to 1/4" Coax	241475-12	
7/8" Coax to 3/8" or 1/2" Coax	241475-9	
7/8" Coax to Antenna Type N or DIN interface	241548-5	
7/8" to APTL5 Arrestors	241474-5	
Connector/Splice Weatherproofing Kit	221213	
Entry Systems – For entry systems offerings see pages 619, 620.		
Standard Cable Entry Boots	4" Boots	5" Boots
One Hole:	204679A-2	48939A-1
Two Hole:	204679A-18	–
Three Hole:	204679A-15	48939A-2
Tools – for additional tool offerings see pages 620-623.		
EASIAx® Plus Automated Cable Prep Tool	CPTL5A	
EASIAx® Cutting Tool	222951	
Cable Flaring Tool	224368	
7/8" Connector Torque Wrench	244378	
DIN Connector Coupling Torque Wrench	244377	
N Connector Coupling Torque Wrench	244379	



7/8" Air Dielectric, HJ Series – 75-ohm

HJ5-75

Description	Type No.
Cable Ordering Information	
Standard and Fire Retardant Cables	
7/8" Standard Cable, Standard Jacket	HJ5-75
7/8" Fire Retardant Jacket (CATVR)	HJ5RN-75
Characteristics	
Electrical	
Impedance, ohms	75 ± 1
Maximum Frequency, GHz	5.6
Velocity, percent	90
Peak Power Rating, kW	60
dc Resistance, ohms/1000 ft (1000 m)	
Inner	0.25 (0.82)
Outer	0.20 (0.66)
dc Breakdown, volts	6000
Jacket Spark, volts RMS	8000
Capacitance, pF/ft (m)	15.1 (49.4)
Inductance, μH/ft (m)	0.085 (0.278)
Mechanical	
Outer Conductor	Copper
Inner Conductor	Copper
Diameter over Jacket, in (mm)	1.11 (28.2)
Diameter over Copper Outer Conductor, in (mm)	1.01 (25.7)
Minimum Bending Radius, in (mm)	10 (250)
Number of Bends, minimum (typical)	15 (20)
Bending Moment, lb-ft (N•m)	25 (34)
Cable Weight, lb/ft (kg/m)	0.52 (0.79)
Tensile Strength, lb (kg)	800 (360)
Flat Plate Crush Strength, lb/in (kg/mm)	250 (4.5)

Attenuation and Average Power Ratings

Frequency MHz	Attenuation dB/100 ft	Attenuation dB/100 m	Average Power, kW
0.5	0.0250	0.0819	60.0
1	0.0355	0.116	54.7
1.5	0.0436	0.143	44.6
2	0.0505	0.166	38.5
10	0.116	0.381	16.4
20	0.168	0.552	11.4
30	0.209	0.686	9.31
50	0.272	0.892	7.13
88	0.363	1.19	5.34
100	0.388	1.27	5.01
108	0.404	1.33	4.80
150	0.480	1.58	4.02
174	0.517	1.70	3.71
200	0.555	1.82	3.45
300	0.687	2.26	2.79
400	0.800	2.63	2.40
450	0.850	2.79	2.25
500	0.898	2.95	2.14
512	0.909	2.98	2.10
600	0.988	3.24	1.93
700	1.07	3.51	1.78
800	1.15	3.77	1.66
824	1.17	3.82	1.64
894	1.22	3.99	1.57
960	1.26	4.14	1.52
1000	1.29	4.23	1.49
1250	1.46	4.78	1.31
1500	1.61	5.28	1.17
1700	1.74	5.70	1.08
2000	1.92	6.30	0.977
2300	2.10	6.89	0.898
3000†	2.49	8.18	0.763
4000	3.00	9.84	0.640
5000	3.40	11.2	0.565
5600	3.65	12.0	0.526

Standard Conditions:

For Attenuation. VSWR 1.0 ambient temperature 20°C (68°F), atmospheric pressure, dry air.

For Average Power, VSWR 1.0, inner temperature 100°C (212°F), ambient temperature 40°C (104°F), atmospheric pressure, dry air, no solar loading.

† Operation of this cable in the 3500-3650 MHz band is not recommended because of VSWR spikes produced by the dielectric section spacing.

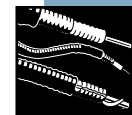

N Female
H5NF-7550



7/8" EIA Flange
75AR-75



N Male
H5NM-7550

Connectors

Interface	Description	Type Number	Inner Contact Attachment	Outer Contact Attachment	Plating Code	Max. Length in (mm)	Max. Dia. in (mm)
N Male	50 Ohm Mating Pin	H5NM-7550	Self-tapping	Tab Flare	BB	3.5 (89)	1.4 (36)
N Female	50 Ohm Mating Pin	H5NF-7550	Self-tapping	Tab Flare	BB	3.9 (99)	1.4 (36)
7/8" EIA Flange	Gas Pass	75AR-75	Self-tapping	Tab Flare	BB	4.3 (109)	2.25 (57)
UHF Female	50 Ohm Mating Pin	75AU-75	Self-tapping	Tab Flare	BB	4.3 (109)	1.4 (36)
LC Male	50 Ohm Mating Pin	75AM-75	Self-tapping	Tab Flare	BB	5.0 (127)	1.4 (36)
End Terminal	-	75AT-75	Self-tapping	Tab Flare	BB	5.8 (147)	1.4 (36)
Splice	-	75AZ-75	Self-tapping	Tab Flare	BB	4.2 (107)	1.4 (36)

Plating Codes: BB - Brass Body and Pin

Accessories

Description	Type No.
Hangers – For more hangers, adapters and mounting hardware see pages 599-607.	
Standard Hangers Kit of 10. Recommended maximum spacing is 3 ft (1 m). For different spacing recommendations, refer to Cable Hanger Spacing, pages 593-598.	42396A-5
Hardware Kit of 10. 3/8" bolts, lockwashers, nuts	
3/4" (19 mm) long	31769-5
1" (25 mm) long	31769-1
Click-On Hangers Kit of 10. Recommended maximum spacing is 3-ft (1 m). Mounting Hardware see page 605.	L5CLICK
Standard Hoisting Grip	19256B

Description	Type No.
Grounding and Surge Protection – for additional grounding kits and our surge protection offerings, see pages 609-616.	
SureGround Grounding Kit with standard weatherproofing	
Factory attached one-hole lug, 600 mm (24") lead	SGL5-06B1
Factory attached two-hole lug, 600 mm (24") lead	SGL5-06B2
Field attached two hole lug, 1500 mm (59") lead	SGL5-15B4
Weatherproofing – for additional weatherproofing information see pages 617, 618.	
Connector/Splice Weatherproofing Kit	221213
Entry Systems – For entry systems offerings see pages 619, 620.	
Standard Cable Entry Boots	
4" Boots	5" Boots
One Hole:	204679A-2 48939A-1
Two Hole:	204679A-18 -
Three Hole:	204679A-15 48939A-2

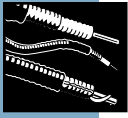

Factory Made Cable Assemblies

HELIAX® Coaxial Cables



SureFlex™

Andrew has state-of-the-art cable assembly facilities all over the world. You no longer have to deal with expensive and labor intensive cable preparation and connector attachment on site. Andrew will do it for you. Our factory automated processes allow us to produce cable assemblies that will meet your specifications, your delivery requirements, and your budget.

HELIAX® cable assemblies are ideal for rack-to-rack and radio OEM applications. They are also commonly used for connecting antennas to transmission lines and transmission lines to radios.

Here are the advantages of the Andrew factory made cable assembly program:

- **Competitive pricing.** *Low attachment charges.*
- **Guaranteed quality.** *Assemblies are 100% tested prior to shipment and include a ten year warranty.*
- **Fast delivery.** *Global manufacturing and inventory.*
- **Complete product offering.** *Any cable, any length, any connector.*
- **Low VSWR assemblies.** *For high performance applications.*

Delivering a Decade of Confidence

We are proud to continue our new 10-year warranty on our HELIAX standard and SureFlex™ cable assembly products, foam-dielectric and air-dielectric coaxial cables, waveguides, connectors, and accessories.

This "repair or replace" warranty covers any defects in material and workmanship that may arise under normal use and service and is available on products sold directly by Andrew and its authorized distributors.

It's all part of our long tradition of commitment to customers. Install Andrew products and receive unsurpassed performance, uncompromising quality, and unmatched durability and reliability - all backed by a ten-year warranty to keep systems operational, not just tomorrow, but well into the future.

Genuine HELIAX Cable

For transmission line systems requiring jumpers, genuine HELIAX cable, 7/8" and under, can provide a high-performance, high-reliability alternative.

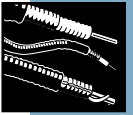

SureFlex™ Cable Assemblies Seal in Performance

Providing excellent performance and an integral weather seal, our new patented, factory automated, SureFlex cable assemblies use an innovative, completely soldered connector attachment to seal in performance and seal out the elements. These new assemblies allow you to benefit from our unparalleled HELIAIX® cable.

SureFlex cable assemblies' unique connector attachment includes a solder connection to both the inner and the outer conductors. The automated attachment process employs an induction soldering technique that ensures 360 degrees of electrical contact and a reliable weather seal. This process ensures a consistent, robust attachment every time.

SureFlex Cable Assemblies provide:

- Stable IMD
- Consistent VSWR
- Complete weatherproofing
- Tightly controlled pin depth
- High pull-off strength

Andrew SureFlex cable assemblies are ideal for wireless systems such as PCS, cellular, and paging.

New SureFlex Arrestor Plus® Cable Assemblies

These SureFlex cable assemblies include all the benefits described plus the protection of an integrated Arrestor Plus surge arrester. The one-piece surge arrester/connector delivers premium lightning protection in a single component that is completely soldered to seal in performance and seal out the elements.

The assemblies are offered with both Quarter Wave Shorting Stub (QWS) surge arrestors and broadband replaceable gas tube arrestors. They include bulkhead mounting and will fit into your base station cabinet or in building applications.

Other Available Cable Assemblies

Any connector and length can be made to order.

Contact Andrew to have an assembly designed for your application.

Standard Cable Assemblies

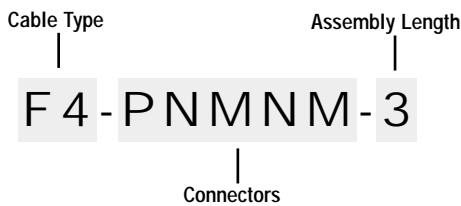

Premium Cable Assemblies

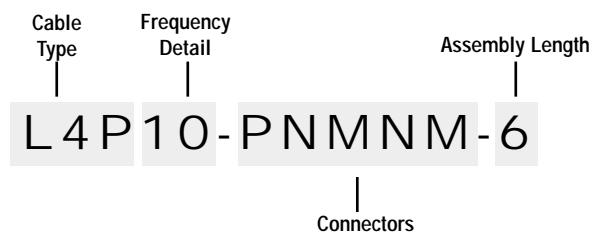

SureFlex Cable Assemblies

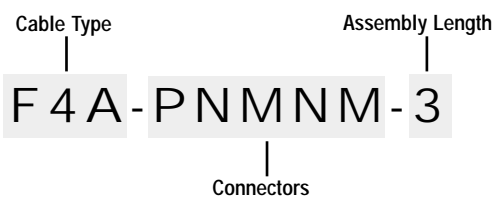

Premium SureFlex Cable Assemblies

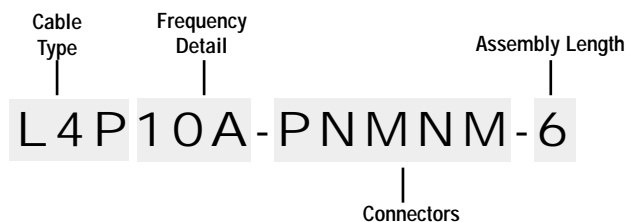



SureFlex™ and Standard Cable Assemblies – Ordering Information

Connectors	SureFlex Type Number	Standard Type Number
FSJ1-50A		
N Male/N Male	F1A-PNMNM-(*)	F1-PNMNM-(*)
N Male/Right Angle N Male	F1A-PNMNR-(*)	F1-PNMNR-(*)
N Male/N Female	-	F1-PNMNF-(*)
N Male/UHF Male	-	F1-PNMUM-(*)
N Male/BNC Male	-	F1-PNMBM-(*)
N Male/SMA Male	-	F1-PNMSM-(*)
N Male/Right Angle SMA Male	-	F1-PNMSR-(*)
7-16 DIN Male/7-16 DIN Male	F1A-PDMDM-(*)	-
SMA Male/SMA Male	-	F1-SMSM-(*)
SMA Male/SMA Female	-	F1-SMSF-(*)
SMA Male/Right Angle SMA Male	-	F1-SMSR-(*)
FSJ2-50		
N Male/N Male	F2A-PNMNM-(*)	F2-PNMNM-(*)
N Male/Right Angle N Male	F2A-PNMNR-(*)	-
N Male/7-16 DIN Male	F2A-PNMMDM-(*)	F2-PNMMDM-(*)
7-16 DIN Male/7-16 DIN Male	F2A-PDMDM-(*)	F2-PDMDM-(*)
7-16 DIN Male/Right Angle 7-16 DIN Male	F2A-PDMDR-(*)	-
N Male/N Female	F2A-PNMNF-(*)	F2-PNMNF-(*)
FSJ4-50B		
N Male/N Male	F4A-PNMNM-(*)	F4-PNMNM-(*)
N Male/N Female	F4A-PNMNF-(*)	F4-PNMNF-(*)
7-16 DIN Male/7-16 DIN Male	F4A-PDMDM-(*)	F4-PDMDM-(*)
7-16 DIN Male/7-16 DIN Female	F4A-PDMDF-(*)	F4-PDMDF-(*)
N Male/7-16 DIN Male	F4A-PNMMDM-(*)	F4-PNMMDM-(*)
7-16 DIN Male/7-16 DIN Female	F4A-PDMDF-(*)	F4-PDMDF-(*)
7-16 DIN Female/Right Angle 7-16 DIN Male	F4A-PDFDR-(*)	F4-PDFDR-(*)
7-16 DIN Male/Right Angle 7-16 DIN Male	F4A-PDMDR-(*)	F4-PDMDR-(*)
7-16 DIN Male/4.1-9.5 DIN Male	F4A-PDMKM-(*)	F4-PDMKM-(*)
N Female/Right Angle N Male	F4A-PNFNR-(*)	F4-PNFNR-(*)
N Male/7-16 DIN Female	F4A-PNMDF-(*)	F4-PNMDF-(*)
N Male/Right Angle 7-16 DIN Male	F4A-PNMDR-(*)	F4-PNMDR-(*)
N Male/4.1-9.5 DIN Male	-	F4-PNMKM-(*)
N Male/Right Angle 4.1-9.5 DIN Male	-	F4-PNMKR-(*)
N Male/Right Angle N Male	F4A-PNMNR-(*)	F4-PNMNR-(*)
Right Angle N Male/7-16 DIN Female	F4A-PNRDF-(*)	F4-PNRDF-(*)
UHF Male/UHF Male	-	F4-UMUM-(*)
7-16 DIN Female/7-16 DIN Female	F4A-PDFDF-(*)	F4-PDFDF-(*)
N Female/7-16 DIN Male	F4A-PNFDM-(*)	F4-PNFDM-(*)
EFX2-50		
7-16 DIN Male/7-16 DIN Female	EFX2A-PDMDF-(*)	EFX2-PDMDF-(*)
7-16 DIN Male/7-16 DIN Male	EFX2A-PDMDM-(*)	EFX2-PDMDM-(*)
N Male/7-16 DIN Male	EFX2A-PNMMDM-(*)	EFX2-PNMMDM-(*)
N Male/N Female	-	EFX2-PNMNF-(*)
N Male/N Male	EFX2A-PNMNM-(*)	EFX2-PNMNM-(*)
N Male/N Male Right Angle	-	EFX2-PNMNR-(*)
N Male Right Angle/7-16 DIN Male Right Angle	-	EFX2-PNRDR-(*)
ETS2-50		
7-16 DIN Male/7-16 DIN Male	-	ETS2-PDMDM-(*)
N Male/7-16 DIN Male	-	ETS2-PNMMDM-(*)
N Male/N Male	-	ETS2-PNMNM-(*)
HST4-50		
7-16 DIN Male/7-16 DIN Male	-	HST4-PDMDM-(*)
N Male/N Male	-	HST4-PNMNM-(*)
N Male/7-16 DIN Male	-	HST4-PNMMDM-(*)
LDF2-50		
N Male/N Male	-	L2-PNMNM-(*)
7-16 DIN Male/7-16 DIN Male	-	L2-PDMDM-(*)
N Male/7-16 DIN Male	-	L2-PNMMDM-(*)
SMA Male/SMA Male	-	L2-SMSM-(*)

SureFlex™ and Standard Cable Assemblies – Ordering Information

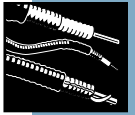

Connectors	SureFlex Type Number	Standard Type Number
LDF4-50A		
N Male/N Male	L4A-PNMNM-(*)	L4-PNMNM-(*)
N Male/N Female	L4A-PNMNF-(*)	L4-PNMNF-(*)
7-16 DIN Male/7-16 DIN Male	L4A-PDMDM-(*)	L4-PDMDM-(*)
7-16 DIN Male/7-16 DIN Female	L4A-PDMDF-(*)	L4-PDMDF-(*)
N Male/7-16 DIN Male	L4A-PNMMDM-(*)	L4-PNMMDM-(*)
N Male/Right Angle 7-16 DIN Male	L4A-PNMMDR-(*)	L4-PNMMDR-(*)
7-16 DIN Male/Right Angle 7-16 DIN Male	L4A-PDRDR-(*)	L4-PDMMDR-(*)
UHF Male/UHF Male	-	L4-UMUM-(*)
UHF Male/UHF female	-	L4-UMUF-(*)
N Male/N Female	L4A-PNMNF-(*)	L4-PNMNF-(*)
Right Angle N Male/7-16 DIN Male	L4A-PNRDM-(*)	L4-PNRDM-(*)
VXL5-50		
7-16 DIN Male/7-16 DIN Male	-	V5-PDMDM-(*)
N Male/N Male	-	V5-PNMNM-(*)
N Male/7-16 DIN Male	-	V5-PNMMDM-(*)
N Female/N Female	-	V5-PNMF-(*)
7-16 DIN Female/7-16 DIN Female	-	V5-PDFDF-(*)

Premium SureFlex Cable Assemblies - Ordering Information

Connectors	Type Number
EFX2P-50-40 Low VSWR Cable (0.806-0.960 GHz), see page 490 for specifications.	
N Male/N Male	EFX2P40A-PNMNM-(*)
N Male/7-16 DIN Male	EFX2P40A-PNMMDM-(*)
7-16 DIN Male/7-16 DIN Male	EFX2P40A-PDMDM-(*)
EFX2P-50-41 Low VSWR Cable (1.7-2.3 GHz), see page 490 for specifications.	
N Male/N Male	EFX2P41A-PNMNM-(*)
N Male/7-16 DIN Male	EFX2P41A-PNMMDM-(*)
7-16 DIN Male/7-16 DIN Male	EFX2P41A-PDMDM-(*)
EFX2P-50-42 Low VSWR Cable (0.806-0.960 and 1.7-2.3 GHz), see page 490 for specifications.	
N Male/N Male	EFX2P42A-PNMNM-(*)
N Male/7-16 DIN Male	EFX2P42A-PNMMDM-(*)
7-16 DIN Male/7-16 DIN Male	EFX2P42A-PDMDM-(*)
FSJ4P-50B-40 Low VSWR Cable (0.806-0.960 GHz), see page 487 for specifications.	
N Male/N Male	F4P40A-PNMNM-(*)
N Male/7-16 DIN Male	F4P40A-PNMMDM-(*)
7-16 DIN Male/7-16 DIN Male	F4P40A-PDMDM-(*)
FSJ4P-50B-41 Low VSWR Cable (0.806-0.960 and 1.7-2.3 GHz), see page 487 for specifications.	
N Male/N Male	F4P41A-PNMNM-(*)
N Male/7-16 DIN Male	F4P41A-PNMMDM-(*)
7-16 DIN Male/7-16 DIN Male	F4P41A-PDMDM-(*)
FSJ4P-50B-42 Low VSWR Cable (1.7-2.3 GHz), see page 487 for specifications.	
N Male/N Male	F4P42A-PNMNM-(*)
N Male/7-16 DIN Male	F4P42A-PNMMDM-(*)
7-16 DIN Male/7-16 DIN Male	F4P42A-PDMDM-(*)
LDF4P-50A-40 Low VSWR Cable (0.806-0.960 GHz), see page 498 for specifications.	
N Male/N Male	L4P40A-PNMNM-(*)
N Male/7-16 DIN Male	L4P40A-PNMMDM-(*)
7-16 DIN Male/7-16 DIN Male	L4P40A-PDMDM-(*)
LDF4P-50A-41 Low VSWR Cable (0.806-0.960 and 1.7-2.3 GHz), see page 498 for specifications.	
N Male/N Male	L4P41A-PNMNM-(*)
N Male/7-16 DIN Male	L4P41A-PNMMDM-(*)
7-16 DIN Male/7-16 DIN Male	L4P41A-PDMDM-(*)
LDF4P-50A-42 Low VSWR Cable (1.7-2.3 GHz), see page 498 for specifications.	
N Male/N Male	L4P42A-PNMNM-(*)
N Male/7-16 DIN Male	L4P42A-PNMMDM-(*)
7-16 DIN Male/7-16 DIN Male	L4P42A-PDMDM-(*)

* Insert length in feet or use M suffix to designate meters. For example, -3 = 3 feet, -2M = 2 meters, and -1M5 = 1.5 meters.

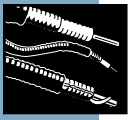

Phase Measured Cable Assemblies

HELIAX® phase measured cable assemblies are excellent for applications where signals arrive in phase such as phased array radar, or for delay lines cut to precision electrical length. Both phase matched and delay lines are available with precision or standard length tolerances and are referred to collectively as phase measured assemblies.

Phase measured assemblies are manufactured from phase stabilized versions of HELIAX coaxial cables and connectors. HELIAX coaxial cables exhibit excellent phase stability with temperature changes and with bending.

Phase Stability with Temperature Change

As temperature changes, the physical length of the metallic conductors of coaxial cable increase causing an increase in the electrical length and transmission delay time. The dielectric constant of materials, such as the low-loss foam dielectric of HELIAX cable, decreases with increasing temperature. This causes an increase in the velocity of propagation of the cable, which results in a decrease in electrical length and transmission delay time. In HELIAX cable, these two effects are of similar magnitude, causing little change in the overall electrical length of the cable. In cables with solid dielectrics, such as RG-214/U, the decrease in electrical length caused by the dielectric constant change is greater than the increase caused by the conductors. Therefore, these cables exhibit larger changes in electrical length. Figures 1 and 2 display this effect.

Phase Stabilized Cable

When foam cable is subjected to temperature changes, its electrical length undergoes a permanent change which cannot be removed by restoring it to the initial temperature. However, this hysteresis effect can be eliminated by temperature cycling the cable until it returns to the same electrical length after each heating (not the same as the initial electrical length). Temperature cycling is used to produce phase stabilized HELIAX cables.

Figures 3 through 6 show the typical behavior of phase stabilized cable with temperature.

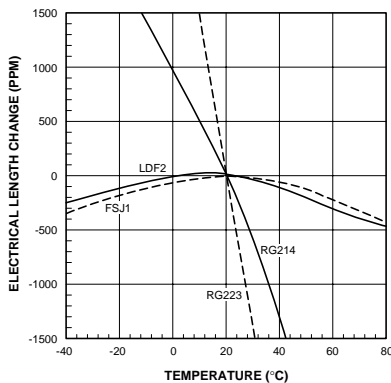

Figure 1

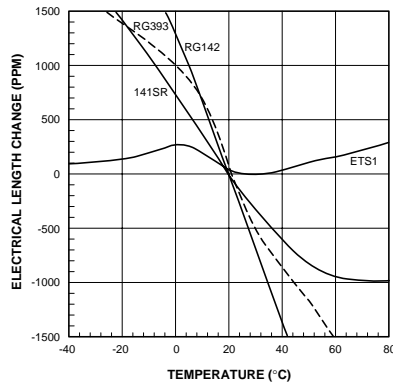

Figure 2

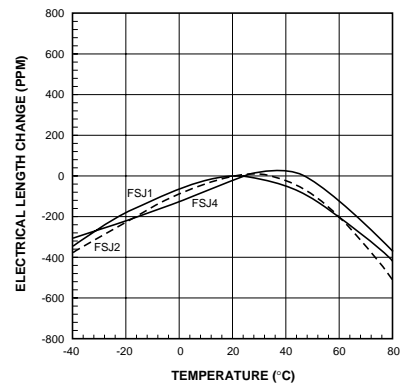
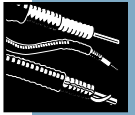

Figure 3 – Electrical Length Change vs. Temperature
FSJ1-50A, FSJ2-50, FSJ4-50B



Converting PPM to Degrees for Specific Applications

Phase Change (Degrees) = $3.66 \times 10^{-7} (\Delta\text{PPM}) (L \cdot F / V)$
 Where: ΔPPM = Total Electrical Length Change in PPM
 Over Temperature Range of Interest (From Figures 3, 4, 5 and 6)

- L = Cable Length, Feet
- F = Frequency, MHz
- V = Cable's Relative Velocity

Sample Calculation

Using the formula above, the change in phase for a system operating at 10 GHz using a 12 ft FSJ4-50B superflexible HELIAX® cable over a temperature range of -40 to 80°C (-40 to 176°F) is calculated as follows:

$$\begin{aligned} \text{Phase Change} &= \frac{3.66 \times 10^{-7} (400) \times 12 \times 10^4}{0.81} \\ &= 21.69^\circ \text{ maximum phase change} \end{aligned}$$

At 1 GHz this equates to just over 2° maximum phase change.

Phase Stability with Bending

When cable is bent during installation, it is important to maintain a constant cable phase length. Stability in bending is enhanced by locking all the cable components together such that the cable bends on its neutral axis.

The foam dielectric in HELIAX cables is bonded to the center conductor, while the outer conductor corrugations mechanically lock the outer conductor to the dielectric. This locking results in excellent stability.

Typical phase change with bending data for HELIAX coaxial cables is given below:

Cable	Bending Radius In (mm)	Test Frequency GHz	Typical Phase Change, 360 Bend, Electrical Degrees/GHz
ETS1-50	1.0 (25)	18.0	0.8
FSJ1-50A	1.0 (25)	18.0	0.2
FSJ2-50	1.0 (25)	13.0	0.4
ETS2-50	1.0 (25)	13.0	0.8
FSJ4-50B	1.25 (32)	10.2	0.5
LDF2-50	3.75 (95)	13.0	0.5
LDF4-50A	5.0 (125)	8.0	0.6
LDF5-50A	10.0 (250)	5.0	0.3
HJ4-50	5.0 (125)	10.0	1.0
HJ5-50	10.0 (250)	5.0	0.8

Phase change with bending is not as repeatable or predictable as phase change with temperature. Results obtained will vary depending on exactly how the cable is bent. The above numbers are intended as a guide to the order of magnitude of change to be expected during installation if bending is required.

HELIAX® Coaxial Cables

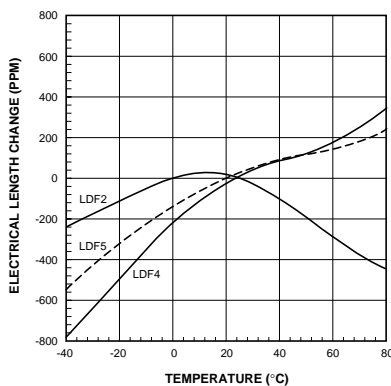

Figure 4 – Electrical Length Change vs. Temperature
 LDF1-50, LDF2-50, LDF4-50A, LDF5-50A

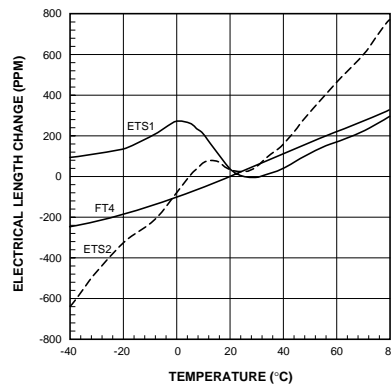

Figure 5 – Electrical Length Change vs. Temperature
 ETS1-50, ETS2-50, FT4-50

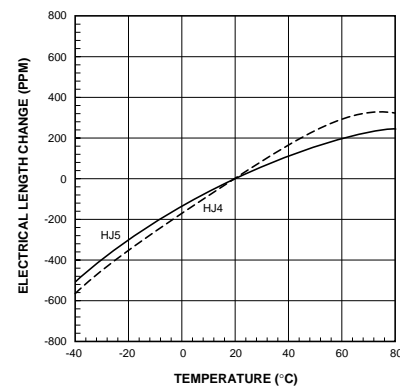

Figure 6 – Electrical Length Change vs. Temperature
 HJ4-50, HJ5-50



Phase Measured Cable Assemblies

Phase Measured Assemblies

Two types of phase measured assemblies are available from Andrew:

Delay Lines. These are assemblies cut to a specific electrical length, specified either in nanoseconds or degrees, at a specified frequency. When several are ordered, their physical length can be expected to vary somewhat.

Phase Matched Assemblies. These are assemblies which are matched in electrical length to each other at a specified frequency. When phase matched assemblies are ordered, their minimum acceptable physical length must be specified, as well as an operating frequency. Andrew will supply assemblies matched in electrical length of this physical length and longer.

Phase Measured Cable – Characteristics and Ordering Information

(Larger sizes also available; contact Andrew.)

	1/4" Superflexible FSJ1-50A	3/8" Superflexible FSJ2-50	1/2" Superflexible FSJ4-50B	1/4" LDF LDF1-50	3/8" LDF LDF2-50	1/2" LDF LDF4-50A	7/8" LDF LDF5-50A
For cable/connector technical information see page:	474	480	485	491	493	496	506
Type Numbers							
Phase Stabilized	35422-33	35422-42	35422-24	35422-50	35422-23	35422-25	35422-26
Delay Line Cut to Electrical Length ± 0.1 ns tolerance (36° /GHz)	42394-133	42394-142	42394-124	42394-150	42394-122	42394-114	42394-115
Delay Line, Precision Tolerance \pm deg/GHz (ns)	42394-333 1.906 (0.0053)	42394-342 2.021 (0.0056)	42394-324 2.222 (0.0062)	42394-350 2.56 (0.0072)	42394-322 2.946 (0.0082)	42394-314 3.466 (0.0096)	42394-315 4.627 (0.0129)
Phase Matched ± 0.1 ns (36° /GHz)	42394-33	42394-42	42394-24	42394-50	42394-22	42394-14	42394-15
Precision Phase Matched \pm deg/GHz (ns)	42394-233 1.906 (0.0053)	42394-242 2.021 (0.0056)	42394-224 2.222 (0.0062)	42394-250 2.56 (0.0072)	42394-222 2.946 (0.0082)	42394-214 3.466 (0.0096)	42394-215 4.627 (0.0129)
Characteristics							
Velocity $\pm 2\%$	84	83	81	86	88	88	89
ft/ns (m/ns) $\pm 2\%*$	0.83 (0.25)	0.82 (0.25)	0.8 (0.24)	0.85 (0.26)	0.87 (0.26)	0.87 (0.26)	0.88 (0.27)
Phase/Temp Coefficient over temp. range -22 to +104° F (-30 to +40°C)	-4 to +5 (-7 to +9)	-5 to +5 (-9 to +9)	-1 to +3 (-2 to +6)	-6 to +5 (-10 to +8)	-4 to +3 (-8 to +6)	+4 to +9 (+7 to +16)	+3 to +7 (+5 to +12)
PPM/ °F (PPM/ °C)							

* For delay lines, the approximate length can be determined by multiplying delay in nanoseconds by the ft/ns factor for the appropriate cable type.

Phase Measured Cable Assemblies

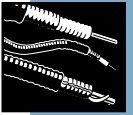

HELIX[®] Coaxial Cables

Two levels of cutting accuracy are available for both delay lines and phase matched assemblies:

Standard Cutting Accuracy. ± 0.1 nanoseconds or $36^\circ/\text{GHz}$. This cutting accuracy is not available for some combinations of test frequency and cable assembly lengths.

Precision Cutting Accuracy. Tolerance per table below. This varies by cable type and is based on one half of the corrugation pitch of the cable. This is as close as the cables can be fit on a production basis. This cutting accuracy is not available for some combinations of test frequency and cable assembly lengths.

Phase Measured Cable – Characteristics and Ordering Information

(Larger sizes also available; contact Andrew.)

	1/4" High Power Superflexible ETS1-50T	3/8" High Power Superflexible ETS2-50T	1/2" Air HJ4-50	7/8" Air HJ5-50	1-5/8" Air HJ7-50A	3" Air HJ8-50B
For cable/connector technical information see page:	477	483	535	555	560	566
Type Numbers						
Phase Stabilized	35422-46	35422-45	35422-8	35422-5	35422-1	35422-41
Delay Line Cut to Electrical Length ± 0.1 ns tolerance ($36^\circ/\text{GHz}$)	42394-146	42394-145	42394-108	42394-105	42394-141	–
Delay Line, Precision Tolerance $\pm \text{deg}/\text{GHz}$ (ns)	42394-346 1.935 (0.0054)	42394-345 2.021 (0.0056)	42394-308 4.121 (0.0114)	42394-305 4.712 (0.0131)	42394-341 –	– –
Phase Matched ± 0.1 ns ($36^\circ/\text{GHz}$)	42394-46	42394-45	42394-8	42394-5	–	–
Precision Phase Matched $\pm \text{deg}/\text{GHz}$ (ns)	42394-246 1.935 (0.0054)	42394-245 2.021 (0.0056)	42394-208 4.121 (0.0114)	42394-205 4.712 (0.0131)	42394-241 –	– –
Characteristics						
Velocity $\pm 2\%$	82	83	91.4	91.6	92.1	93.3
ft/ns (m/ns) $\pm 2\%*$	0.81 (0.25)	0.82 (0.25)	0.9 (0.27)	0.9 (0.27)	–	–
Phase/Temp Coefficient over temp. range -22 to +104° F (-30 to +40°C)	-9 to +6 (-16 to +10)	-5 to +7 (-8 to +13)	+3 to +6 (+5 to +11)	+3 to +6 (+5 to +11)	–	–
PPM/ °F (PPM/ °C)						

* For delay lines, the approximate length can be determined by multiplying delay in nanoseconds by the ft/ns factor for the appropriate cable type.



System Timing

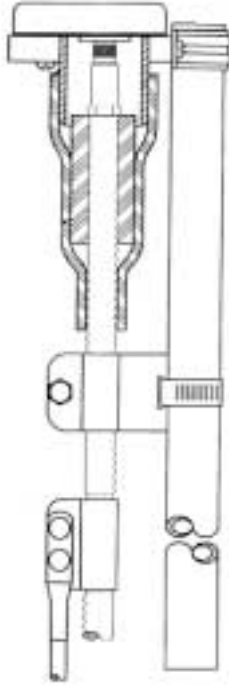

Andrew GPS Antenna Kits Speed Installation, Simplify Ordering

Obtain a complete GPS antenna system packaged in a single comprehensive kit. The GPS Antenna System Kit features everything required to establish GPS capabilities for PCS applications. This weatherproof system is designed for outdoor use. It has been tested to meet the following specifications:

Test	Test Specifications
Thermal shock	MIL-STD-202, method 107, condition A-1, -55OC to +85OC
Moisture resistance	IEC 529, Class IPX4S

Kits Include:

- GPS antenna integrated with a 26 dB low-noise amplifier with a Type N female connector. A 5-volt dc bias is required, via the center conductor, to power the integrated low-noise pre-amplifier.
- HELIAX® connectors. (1/2" LDF4, 1/2" FSJ4 or 7/8" LDF5 HELIAX cable is ordered separately to length)
- HELIAX cable hangers, grounding kit, and 3M™ Cold Shrink™ self-applicating weatherproofing kit..
- Antenna mounting plate and mast shroud.

Ordering Information

GPS-KIT12	GPS Antenna Kit for 1/2" LDF4 HELIAX Cable
GPS-KITF4	GPS Antenna Kit for 1/2" FSJ4 HELIAX Cable
GPS-KIT78	GPS Antenna Kit for 7/8" LDF5 HELIAX Cable

Hanger Spacing Considerations

Hanger Spacing Tables. Recommended hanger spacing is tabulated, on the following pages, for various HELIAX® hangers and cable types. The recommended hanger spacing is tabulated as a function of wind speed and ice conditions. These recommendations have been derived from extensive mechanical, environmental, and wind tunnel testing. They are based on the guidelines stated in EIA Standard RS-222 (Structural Standards for Steel Antenna Towers and Antenna Supporting Structures) and BSI CP3: Chapter V: Part 2 (Code of Basic Data for the Design of Buildings, Wind Loading). The recommendations assume that proper structural mounting arrangements and installation procedures are adhered to.

The recommended hanger spacings are tabulated as a function of wind speed and radial ice only. However, there are many other factors that must be taken into consideration when determining hanger spacing.

Geographical Considerations. Geographical location may have a significant impact on installation conditions. Coastal installations may be in the path of hurricanes producing high values of sustained wind. Mountainous regions may experience extreme wind gusts. Geographical location also dictates the "design basic wind speed", which is the highest wind speed, at a height of 10 meters, over open terrain. Published values of basic wind speed are compiled for various counties and states and are found in EIA TIA-222-E.

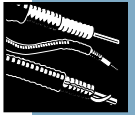

Structural Considerations. Andrew hangers are designed for severe mechanical and environmental conditions. However, the mounting arrangement and structural integrity of the tower or structure, to which the hangers are attached, must be taken into account. A poorly designed mounting structure may result in excessive vibration, subjecting the hanger to extreme stress and fatigue. In such cases, the mounting geometry should be re-evaluated and the hanger spacing reduced.

Height Considerations. The height of the tower, to which the hangers are attached, as well as the height above average ground level, must be considered when calculating hanger spacing. For towers and structures exceeding 150 feet, it is important to review the requirements and guidelines stated in EIA Standard RS-222 (Structural Standards for Steel Antenna Towers and Antenna Supporting Structures). Wind loading results in horizontal forces being applied to hangers. The horizontal force applied to each hanger and tower section can be approximated by (see EIA TIA-222-E):

$$F = \text{Wind Load Applied to Hanger} = q_z C_f A_p G_H$$

$$q_z = \text{Velocity Pressure} = 0.00256 K_z (V)^2$$

$$K_z = \text{Velocity Pressure Exposure Coefficient} = (Z/33)^{0.286}$$

(for z in feet and $1 < K_z < 2.58$)

$$Z = \text{Height Above Average Ground Level to Midpoint of the Section}$$

$$V = \text{Basic Wind Speed}$$

$$G_H = \text{Gust Response Factor} = (\text{see EIA-222})$$

$$C_f = \text{Structure Force Coefficient (1.2 for cable)}$$

$$A_p = \text{Projected Area (Cable Diameter x Hanger Spacing)}$$

Combining the above variables, we see that the force, applied to a hanger due to wind loading, is equal to the following:

$$F = \text{Wind Load Applied to Hanger} = 0.00256 (Z/33)^{0.286} (V)^2 C_f G_H (\text{Cable Diameter x Hanger Spacing})$$

From the above equations we can see that the velocity pressure exposure coefficient and the gust response factor introduce some height dependence when considering the amount of force subjected to an individual hanger.

Icing Considerations. A large accumulation of radial ice will dramatically increase the projected area, resulting in a significant increase in loading. It is important to know if, for the given geographic area, significant icing and high wind loading are occurring simultaneously. However, the probability of an extreme ice loading occurring simultaneously with an extreme wind load is low allowing some reduction in overall wind loading.

Wind Loading. The loads experienced by a hanger transmitted through the cable arise from various phenomena. However, the above equation states, the very important relationship, that the force subjected to an individual hanger is proportional to the square of the wind velocity. Therefore, for extreme wind loading environments, it is critical to carefully review hanger spacing considerations and adhere to proper mounting procedures. Aside from the weight of the cable and ice accumulation, the hanger's holding integrity is impacted predominantly by the static drag load, vortex shedding, and atmospheric turbulence induced from wind, as well as the natural resonating frequencies of the structure.

Surviving Severe Conditions. Andrew hangers are designed and extensively tested for their mechanical integrity, their ability to survive severe environmental conditions, and their ability to support transmission lines, without creating electrical discontinuities. Laboratory testing includes wind tunnel testing, ice loading, axial loading, vibration, static side loading, normal loading, thermal cycling, salt spray (corrosion), UV exposure, metallurgical evaluation, time domain reflectometry and VSWR. Proper selection of hanger type, hanger spacing, and hanger installation will ensure that these hangers will withstand the most demanding requirements for your wireless system.



The maximum spacing recommendations assume that all hangers are properly installed and tightened. Recommendations for a 150 ft (46 m) tower with 125 mph (200 km/h) wind speed and 1/2" radial ice (typical conditions) are highlighted in red. See "Hanger Spacing Considerations," page 593 for further information.

Standard Hangers – Recommended Maximum Hanger Spacing

Cable Size	Cable Type Number	Hanger Type Number	Recommended Maximum Hanger Spacing, feet (meters)					
			85 mph (137 km/h)			100 mph (160 km/h)		
Wind Speed:	Radial Ice:		No Ice	1/2" (13 mm)	1" (25 mm)	No Ice	1/2" (13 mm)	1" (25 mm)
1/2"	LDF4-50A	43211A	5 (1.5)	4 (1.2)	3 (0.9)	5 (1.5)	4 (1.2)	3 (0.9)
1/2"	LDF4-75A	43211A	5 (1.5)	4 (1.2)	3 (0.9)	5 (1.5)	4 (1.2)	3 (0.9)
1/2"	HL4RP-50	43211A	5 (1.5)	4 (1.2)	3 (0.9)	5 (1.5)	4 (1.2)	3 (0.9)
1/2"	HJ4-50	43211A	5 (1.5)	4 (1.2)	3 (0.9)	5 (1.5)	4 (1.2)	3 (0.9)
1/2"	HLT4-50	43211A	5 (1.5)	4 (1.2)	3 (0.9)	5 (1.5)	3 (0.9)	2 (0.6)
1/2"	HT4-50	43211A	5 (1.5)	4 (1.2)	3 (0.9)	5 (1.5)	4 (1.2)	3 (0.9)
1/2"	HST4-50	43211A	5 (1.5)	3 (0.9)	3 (0.9)	4 (1.2)	3 (0.9)	2 (0.6)
1/2"	HS4RP-50	43211A	5 (1.5)	3 (0.9)	3 (0.9)	4 (1.2)	3 (0.9)	2 (0.6)
1/2"	FSJ4-50B	43211A	5 (1.5)	3 (0.9)	3 (0.9)	4 (1.2)	3 (0.9)	2 (0.6)
1/2"	FSJ4-75A	43211A	5 (1.5)	3 (0.9)	3 (0.9)	4 (1.2)	3 (0.9)	2 (0.6)
5/8"	LDF4.5-50	42396A-9	5 (1.5)	5 (1.5)	4 (1.2)	5 (1.5)	5 (1.5)	4 (1.2)
5/8"	HJ4.5-50	42396A-9	5 (1.5)	5 (1.5)	4 (1.2)	5 (1.5)	5 (1.5)	4 (1.2)
7/8"	LDF5-50A	42396A-5	5 (1.5)	5 (1.5)	4 (1.2)	5 (1.5)	5 (1.5)	4 (1.2)
7/8"	HJ5-50	42396A-5	5 (1.5)	5 (1.5)	4 (1.2)	5 (1.5)	5 (1.5)	4 (1.2)
7/8"	HJ5-75	42396A-5	5 (1.5)	5 (1.5)	4 (1.2)	5 (1.5)	5 (1.5)	4 (1.2)
7/8"	HT5-50	42396A-5	5 (1.5)	5 (1.5)	4 (1.2)	5 (1.5)	5 (1.5)	4 (1.2)
1-1/4"	LDF6-50	42396A-1	4 (1.2)	4 (1.2)	4 (1.2)	4 (1.2)	4 (1.2)	3 (0.9)
1-5/8"	LDF7-50A	42396A-2	4 (1.2)	4 (1.2)	4 (1.2)	4 (1.2)	3 (0.9)	3 (0.9)
1-5/8"	HJ7-50A	42396A-2	4 (1.2)	4 (1.2)	4 (1.2)	4 (1.2)	3 (0.9)	3 (0.9)
2-1/4"	LDF12-50	42395A-4	4 (1.2)	4 (1.2)	4 (1.2)	4 (1.2)	3 (0.9)	3 (0.9)
2-1/4"	HJ12-50	42396A-4	4 (1.2)	4 (1.2)	4 (1.2)	4 (1.2)	3 (0.9)	3 (0.9)
3"	HJ8-50B	31766A-11	5 (1.5)	5 (1.5)	5 (1.5)	5 (1.5)	5 (1.5)	5 (1.5)
4"	HJ11-50B	31766A-10	5 (1.5)	5 (1.5)	5 (1.5)	5 (1.5)	5 (1.5)	5 (1.5)
5"	HJ9HP-50	33598-5	5 (1.5)	5 (1.5)	5 (1.5)	5 (1.5)	5 (1.5)	5 (1.5)
5"	HJ9-50	33598-5	5 (1.5)	5 (1.5)	5 (1.5)	5 (1.5)	5 (1.5)	5 (1.5)
Wind Speed:	Radial Ice:		125 mph (200 km/h)			150 mph (240 km/h)		
			No Ice	1/2" (13 mm)	1" (25 mm)	No Ice	1/2" (13 mm)	1" (25 mm)
1/2"	LDF4-50A	43211A	4 (1.2)	3 (0.9)	2 (0.6)	3 (0.9)	2 (0.6)	1 (0.3)
1/2"	LDF4-75A	43211A	4 (1.2)	3 (0.9)	2 (0.6)	3 (0.9)	2 (0.6)	1 (0.3)
1/2"	HL4RP-50	43211A	4 (1.2)	3 (0.9)	2 (0.6)	3 (0.9)	2 (0.6)	1 (0.3)
1/2"	HJ4-50	43211A	4 (1.2)	3 (0.9)	2 (0.6)	3 (0.9)	2 (0.6)	1 (0.3)
1/2"	HLT4-50	43211A	4 (1.2)	3 (0.9)	2 (0.6)	3 (0.9)	2 (0.6)	1 (0.3)
1/2"	HT4-50	43211A	4 (1.2)	3 (0.9)	2 (0.6)	3 (0.9)	2 (0.6)	1 (0.3)
1/2"	HST4-50	43211A	3 (0.9)	2 (0.6)	2 (0.6)	3 (0.9)	2 (0.6)	1 (0.3)
1/2"	HS4RP-50	43211A	3 (0.9)	2 (0.6)	2 (0.6)	3 (0.9)	2 (0.6)	1 (0.3)
1/2"	FSJ4-50B	43211A	3 (0.9)	2 (0.6)	2 (0.6)	3 (0.9)	2 (0.6)	1 (0.3)
1/2"	FSJ4-75A	43211A	3 (0.9)	2 (0.6)	2 (0.6)	3 (0.9)	2 (0.6)	1 (0.3)
5/8"	LDF4.5-50	42396A-9	5 (1.5)	4 (1.2)	3 (0.9)	4 (1.2)	3 (0.9)	3 (0.9)
5/8"	HJ4.5-50	42396A-9	5 (1.5)	4 (1.2)	3 (0.9)	4 (1.2)	3 (0.9)	3 (0.9)
7/8"	LDF5-50A	42396A-5	5 (1.5)	4 (1.2)	3 (0.9)	4 (1.2)	3 (0.9)	2 (0.6)
7/8"	HJ5-50	42396A-5	5 (1.5)	4 (1.2)	3 (0.9)	4 (1.2)	3 (0.9)	2 (0.6)
7/8"	HJ5-75	42396A-5	5 (1.5)	4 (1.2)	3 (0.9)	4 (1.2)	3 (0.9)	2 (0.6)
7/8"	HT5-50	42396A-5	5 (1.5)	4 (1.2)	3 (0.9)	4 (1.2)	3 (0.9)	2 (0.6)
1-1/4"	LDF6-50	42396A-1	4 (1.2)	4 (1.2)	3 (0.9)	3 (0.9)	3 (0.9)	3 (0.9)
1-5/8"	LDF7-50A	42396A-2	3 (0.9)	3 (0.9)	3 (0.9)	3 (0.9)	3 (0.9)	2 (0.6)
1-5/8"	HJ7-50A	42396A-2	3 (0.9)	3 (0.9)	3 (0.9)	3 (0.9)	3 (0.9)	2 (0.6)
2-1/4"	LDF12-50	42395A-4	3 (0.9)	3 (0.9)	3 (0.9)	3 (0.9)	3 (0.9)	3 (0.9)
2-1/4"	HJ12-50	42396A-4	3 (0.9)	3 (0.9)	3 (0.9)	3 (0.9)	3 (0.9)	3 (0.9)
3"	HJ8-50B	31766A-11	5 (1.5)	5 (1.5)	5 (1.5)	5 (1.5)	5 (1.5)	5 (1.5)
4"	HJ11-50B	31766A-10	5 (1.5)	5 (1.5)	5 (1.5)	5 (1.5)	5 (1.5)	5 (1.5)
5"	HJ9HP-50	33598-5	5 (1.5)	5 (1.5)	5 (1.5)	5 (1.5)	5 (1.5)	5 (1.5)
5"	HJ9-50	33598-5	5 (1.5)	5 (1.5)	5 (1.5)	5 (1.5)	5 (1.5)	5 (1.5)

Definitions and Assumptions 1. Per EIA-222 Standard: Coefficient of drag for coaxial cable is 1.2 (cylindrical members). Ice forms completely around member (360 degrees). Combined wind and ice loading is reduced by 25% to reflect lower probability of wind and ice occurring simultaneously. 2. Wind speeds are maximum, which includes gust factors and exposure factors.

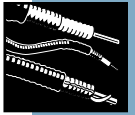

The maximum spacing recommendations assume that all hangers are properly installed and tightened. Recommendations for a 150 ft (46 m) tower with 125 mph (200 km/h) wind speed and 1/2" radial ice (typical conditions) are highlighted in red. See "Hanger Spacing Considerations," page 593 for further information.

Snap-In Hangers – Recommended Maximum Hanger Spacing

Cable Size	Cable Type Number	Hanger Type Number	Recommended Maximum Hanger Spacing, feet (meters)					
			85 mph (137 km/h)			100 mph (160 km/h)		
Wind Speed:	Radial Ice:		No Ice	1/2" (13 mm)	1" (25 mm)	No Ice	1/2" (13 mm)	1" (25 mm)
1/2"	LDF4-50A	206706A-1	4 (1.22)	4 (1.22)	3 (0.91)	4 (1.22)	3 (0.91)	2 (0.61)
1/2"	LDF4-75	206706A-1	4 (1.22)	4 (1.22)	3 (0.91)	4 (1.22)	3 (0.91)	2 (0.61)
1/2"	FSJ4-50B	206706A-1	4 (1.22)	3 (0.91)	2 (0.61)	3 (0.91)	2 (0.61)	2 (0.61)
1/2"	FSJ4-75A	206706A-1	4 (1.22)	3 (0.91)	2 (0.61)	3 (0.91)	2 (0.61)	2 (0.61)
1/2"	HL4RP-50	206706A-1	4 (1.22)	4 (1.22)	3 (0.91)	4 (1.22)	3 (0.91)	2 (0.61)
1/2"	HLT4-50	206706A-1	4 (1.22)	4 (1.22)	3 (0.91)	4 (1.22)	3 (0.91)	2 (0.61)
1/2"	HS4RP-50	206706A-1	4 (1.22)	4 (1.22)	3 (0.91)	4 (1.22)	3 (0.91)	2 (0.61)
1/2"	HST4-50	206706A-1	4 (1.22)	4 (1.22)	3 (0.91)	4 (1.22)	3 (0.91)	2 (0.61)
1/2"	HT4-50	206706A-1	4 (1.22)	4 (1.22)	3 (0.91)	4 (1.22)	3 (0.91)	2 (0.61)
1/2"	HJ4-50	206706A-1	4 (1.22)	4 (1.22)	3 (0.91)	4 (1.22)	3 (0.91)	2 (0.61)
5/8"	LDF4.5-50	206706A-6	4 (1.22)	4 (1.22)	3 (0.91)	4 (1.22)	3 (0.91)	2 (0.61)
7/8"	LDF5-50A	206706A-2	4 (1.22)	3 (0.91)	3 (0.91)	3 (0.91)	3 (0.91)	2 (0.61)
7/8"	HJ5-50	206706A-2	4 (1.22)	3 (0.91)	3 (0.91)	3 (0.91)	3 (0.91)	2 (0.61)
7/8"	HJ5-75	206706A-2	4 (1.22)	3 (0.91)	3 (0.91)	3 (0.91)	3 (0.91)	2 (0.61)
7/8"	HT5-50	206706A-2	4 (1.22)	3 (0.91)	3 (0.91)	3 (0.91)	3 (0.91)	2 (0.61)
7/8"	FT5-50T	206706A-2	4 (1.22)	3 (0.91)	3 (0.91)	3 (0.91)	3 (0.91)	2 (0.61)
1-1/4"	LDF6-50	206706A-3	3 (0.91)	3 (0.91)	3 (0.91)	3 (0.91)	3 (0.91)	2 (0.61)
1-5/8"	LDF7-50A	206706A-4	3 (0.91)	3 (0.91)	3 (0.91)	3 (0.91)	3 (0.91)	2 (0.61)
1-5/8"	HJ7-50A	206706A-4	3 (0.91)	3 (0.91)	3 (0.91)	3 (0.91)	3 (0.91)	2 (0.61)
2-1/4"	LDF12-50	206706A-5	3 (0.91)	3 (0.91)	3 (0.91)	3 (0.91)	2 (0.61)	2 (0.61)
Wind Speed:	Radial Ice:		125 mph (200 km/h)			150 mph (240 km/h)		
			No Ice	1/2" (13 mm)	1" (25 mm)	No Ice	1/2" (13 mm)	1" (25 mm)
1/2"	LDF4-50A	206706A-1	3 (0.91)	3 (0.91)	2 (0.61)	3 (0.91)	2 (0.61)	1 (0.30)
1/2"	LDF4-75	206706A-1	3 (0.91)	3 (0.91)	2 (0.61)	3 (0.91)	2 (0.61)	1 (0.30)
1/2"	FSJ4-50B	206706A-1	3 (0.91)	2 (0.61)	1 (0.30)	2 (0.61)	2 (0.61)	1 (0.30)
1/2"	FSJ4-75A	206706A-1	3 (0.91)	2 (0.61)	1 (0.30)	2 (0.61)	2 (0.61)	1 (0.30)
1/2"	HL4RP-50	206706A-1	3 (0.91)	3 (0.91)	2 (0.61)	3 (0.91)	2 (0.61)	1 (0.30)
1/2"	HLT4-50	206706A-1	3 (0.91)	3 (0.91)	2 (0.61)	3 (0.91)	2 (0.61)	1 (0.30)
1/2"	HS4RP-50	206706A-1	3 (0.91)	3 (0.91)	2 (0.61)	3 (0.91)	2 (0.61)	1 (0.30)
1/2"	HST4-50	206706A-1	3 (0.91)	3 (0.91)	2 (0.61)	3 (0.91)	2 (0.61)	1 (0.30)
1/2"	HT4-50	206706A-1	3 (0.91)	3 (0.91)	2 (0.61)	3 (0.91)	2 (0.61)	1 (0.30)
1/2"	HJ4-50	206706A-1	3 (0.91)	3 (0.91)	2 (0.61)	3 (0.91)	2 (0.61)	1 (0.30)
5/8"	LDF4.5-50	206706A-6	3 (0.91)	3 (0.91)	2 (0.61)	2 (0.61)	2 (0.61)	1 (0.30)
7/8"	LDF5-50A	206706A-2	3 (0.91)	3 (0.91)	2 (0.61)	2 (0.61)	1 (0.30)	1 (0.30)
7/8"	HJ5-50	206706A-2	3 (0.91)	3 (0.91)	2 (0.61)	2 (0.61)	1 (0.30)	1 (0.30)
7/8"	HJ5-75	206706A-2	3 (0.91)	3 (0.91)	2 (0.61)	2 (0.61)	1 (0.30)	1 (0.30)
7/8"	HT5-50	206706A-2	3 (0.91)	3 (0.91)	2 (0.61)	2 (0.61)	1 (0.30)	1 (0.30)
7/8"	FT5-50T	206706A-2	3 (0.91)	3 (0.91)	2 (0.61)	2 (0.61)	1 (0.30)	1 (0.30)
1-1/4"	LDF6-50	206706A-3	3 (0.91)	3 (0.91)	2 (0.61)	2 (0.61)	1 (0.30)	1 (0.30)
1-5/8"	LDF7-50A	206706A-4	3 (0.91)	3 (0.91)	2 (0.61)	2 (0.61)	1 (0.30)	1 (0.30)
1-5/8"	HJ7-50A	206706A-4	3 (0.91)	3 (0.91)	2 (0.61)	2 (0.61)	1 (0.30)	1 (0.30)
2-1/4"	LDF12-50	206706A-5	2 (0.61)	2 (0.61)	1 (0.30)	2 (0.61)	1 (0.30)	1 (0.30)

Definitions and Assumptions 1. Per EIA-222 Standard: Coefficient of drag for coaxial cable is 1.2 (cylindrical members). Ice forms completely around member (360 degrees). Combined wind and ice loading is reduced by 25% to reflect lower probability of wind and ice occurring simultaneously. **2.** Wind speeds are maximum, which includes gust factors and exposure factors.



The maximum spacing recommendations assume that all hangers are properly installed and tightened. Recommendations for a 150 ft (46 m) tower with 125 mph (200 km/h) wind speed and 1/2" radial ice (typical conditions) are highlighted in red. See "Hanger Spacing Considerations," page 593 for further information.

Insulated Hangers – Recommended Maximum Hanger Spacing

Cable Size	Cable Type Number	Hanger Type Number	Recommended Maximum Hanger Spacing, feet (meters)					
			85 mph (137 km/h)			100 mph (160 km/h)		
			Wind Speed: Radial Ice:	No Ice	1/2" (13 mm)	1" (25 mm)	No Ice	1/2" (13 mm)
1/4"	FSJ1-75A	11662-3	3.5 (1.07)	2 (0.61)	1.5 (0.46)	3 (0.91)	1.5 (0.46)	1 (0.30)
1/4"	HST1-50	11662-3	4.5 (1.37)	2.5 (0.76)	2 (0.61)	4 (1.22)	2 (0.61)	1.5 (0.46)
1/4"	LDF1-50	11662-3	4.5 (1.37)	2.5 (0.76)	2 (0.61)	4 (1.22)	2.5 (0.76)	1.5 (0.46)
3/8"	EFX2-50	11662-3	5.5 (1.68)	3.5 (1.07)	2.5 (0.76)	4.5 (1.37)	3 (0.91)	2 (0.61)
3/8"	ETS2-50	11662-3	5.5 (1.68)	3.5 (1.07)	2.5 (0.76)	5 (1.52)	3 (0.91)	2 (0.61)
3/8"	FSJ2-50	11662-3	5.5 (1.68)	3.5 (1.07)	2.5 (0.76)	5 (1.52)	3 (0.91)	2 (0.61)
3/8"	HS2RP-50	11662-3	5.5 (1.68)	3.5 (1.07)	2.5 (0.76)	5 (1.52)	3 (0.91)	2 (0.61)
3/8"	HST2-50	11662-3	5.5 (1.68)	3.5 (1.07)	2.5 (0.76)	5 (1.52)	3 (0.91)	2 (0.61)
3/8"	LDF2-50	11662-3	5 (1.52)	3 (0.91)	2.5 (0.76)	4 (1.22)	2.5 (0.76)	2 (0.61)
1/2"	FSJ4-50B	11662-3	5.5 (1.68)	3.5 (1.07)	3 (0.91)	4.5 (1.37)	3 (0.91)	2.5 (0.76)
1/2"	FSJ4-75A	11662-3	5.5 (1.68)	3.5 (1.07)	3 (0.91)	4.5 (1.37)	3 (0.91)	2.5 (0.76)
1/2"	LDF4-50A	11662-3	6 (1.83)	4 (1.22)	3.5 (1.07)	5 (1.52)	3.5 (1.07)	2.5 (0.76)
1/2"	LDF4-75A	11662-3	6 (1.83)	4 (1.22)	3.5 (1.07)	5 (1.52)	3.5 (1.07)	2.5 (0.76)
1/2"	HL4RP-50	11662-3	6 (1.83)	4 (1.22)	3.5 (1.07)	5 (1.52)	3.5 (1.07)	2.5 (0.76)
1/2"	HLT4-50	11662-3	6 (1.83)	4 (1.22)	3.5 (1.07)	5 (1.52)	3.5 (1.07)	2.5 (0.76)
1/2"	HS4RP-50	11662-3	5.5 (1.68)	3.5 (1.07)	3 (0.91)	4.5 (1.37)	3 (0.91)	2.5 (0.76)
1/2"	HST4-50	11662-3	5.5 (1.68)	3.5 (1.07)	3 (0.91)	4.5 (1.37)	3 (0.91)	2.5 (0.76)
1/2"	HT4-50	11662-3	6 (1.83)	6 (1.83)	5.5 (1.68)	6 (1.83)	6 (1.83)	4.5 (1.37)
1/2"	HJ4-50	11662-3	6 (1.83)	6 (1.83)	5.5 (1.68)	6 (1.83)	6 (1.83)	5 (1.52)
7/8"	LDF5-50A	11662-2	6 (1.83)	6 (1.83)	6 (1.83)	6 (1.83)	6 (1.83)	5.5 (1.68)
7/8"	HJ5-50	11662-2	6 (1.83)	6 (1.83)	6 (1.83)	6 (1.83)	6 (1.83)	6 (1.83)
7/8"	HJ5-75	11662-2	6 (1.83)	6 (1.83)	6 (1.83)	6 (1.83)	6 (1.83)	6 (1.83)
7/8"	HT5-50	11662-2	6 (1.83)	6 (1.83)	6 (1.83)	6 (1.83)	6 (1.83)	6 (1.83)
1-1/4"	LDF6-50	33948-5	6 (1.83)	6 (1.83)	6 (1.83)	6 (1.83)	6 (1.83)	6 (1.83)
1-5/8"	HJ7-50A	33948-3	6 (1.83)	6 (1.83)	6 (1.83)	6 (1.83)	6 (1.83)	6 (1.83)
1-5/8"	LDF7-50A	33948-3	6 (1.83)	6 (1.83)	6 (1.83)	6 (1.83)	6 (1.83)	6 (1.83)
2-1/4"	HJ12-50	33948-6	6 (1.83)	6 (1.83)	6 (1.83)	6 (1.83)	6 (1.83)	6 (1.83)
2-1/4"	LDF12-50	33948-6	6 (1.83)	6 (1.83)	6 (1.83)	6 (1.83)	6 (1.83)	6 (1.83)
3"	HJ8-50B	33948-2	6 (1.83)	6 (1.83)	6 (1.83)	6 (1.83)	6 (1.83)	6 (1.83)
4"	HJ11-50	33948-4	6 (1.83)	6 (1.83)	6 (1.83)	6 (1.83)	6 (1.83)	6 (1.83)
5"	HJ9-50	33948-1	6 (1.83)	6 (1.83)	6 (1.83)	6 (1.83)	6 (1.83)	6 (1.83)
5"	HJ9HP-50	33948-1	6 (1.83)	6 (1.83)	6 (1.83)	6 (1.83)	6 (1.83)	6 (1.83)

Definitions and Assumptions 1. Per EIA-222 Standard: Coefficient of drag for coaxial cable is 1.2 (cylindrical members). Ice forms completely around member (360 degrees). Combined wind and ice loading is reduced by 25% to reflect lower probability of wind and ice occurring simultaneously. 2. Wind speeds are maximum, which includes gust factors and exposure factors.

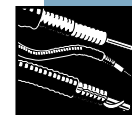

The maximum spacing recommendations assume that all hangers are properly installed and tightened. Recommendations for a 150 ft (46 m) tower with 125 mph (200 km/h) wind speed and 1/2" radial ice (typical conditions) are highlighted in red. See "Hanger Spacing Considerations," page 593 for further information.

Insulated Hangers – Recommended Maximum Hanger Spacing

Cable Size	Cable Type Number	Hanger Type Number	Recommended Maximum Hanger Spacing, feet (meters)					
			125 mph (200 km/h)			150 mph (240 km/h)		
Wind Speed:			No Ice	1/2" (13 mm)	1" (25 mm)	No Ice	1/2" (13 mm)	1" (25 mm)
Radial Ice:								
1/4"	FSJ1-75A	11662-3	2.5 (0.76)	1 (0.30)	1 (0.30)	2 (0.61)	1 (0.30)	0.5 (0.15)
1/4"	HST1-50	11662-3	3 (0.91)	1.5 (0.46)	1 (0.30)	2.5 (0.76)	1.5 (0.46)	1 (0.30)
1/4"	LDF1-50	11662-3	3 (0.91)	2.5 (0.76)	1.5 (0.46)	2.5 (0.76)	1.5 (0.46)	1 (0.30)
3/8"	EFX2-50	11662-3	3.5 (1.07)	2 (0.61)	1.5 (0.46)	3 (0.91)	2 (0.61)	1.5 (0.46)
3/8"	ETS2-50	11662-3	4 (1.22)	2.5 (0.76)	1.5 (0.46)	3 (0.91)	2 (0.61)	1.5 (0.46)
3/8"	FSJ2-50	11662-3	4 (1.22)	2.5 (0.76)	1.5 (0.46)	3 (0.91)	2 (0.61)	1.5 (0.46)
3/8"	HS2RP-50	11662-3	4 (1.22)	2 (0.61)	1.5 (0.46)	3 (0.91)	2 (0.61)	1.5 (0.46)
3/8"	HST2-50	11662-3	4 (1.22)	2 (0.61)	1.5 (0.46)	3 (0.91)	2 (0.61)	1.5 (0.46)
3/8"	LDF2-50	11662-3	3.5 (1.07)	2 (0.61)	1.5 (0.46)	2.5 (0.76)	1.5 (0.46)	1 (0.30)
1/2"	FSJ4-50B	11662-3	3.5 (1.07)	2.5 (0.76)	2 (0.61)	3 (0.91)	2 (0.61)	1.5 (0.46)
1/2"	FSJ4-75A	11662-3	3.5 (1.07)	2.5 (0.76)	2 (0.61)	3 (0.91)	2 (0.61)	1.5 (0.46)
1/2"	LDF4-50A	11662-3	4 (1.22)	3 (0.91)	2 (0.61)	3 (0.91)	2.5 (0.76)	1.5 (0.46)
1/2"	LDF4-75A	11662-3	4 (1.22)	3 (0.91)	2 (0.61)	3 (0.91)	2.5 (0.76)	1.5 (0.46)
1/2"	HL4RP-50	11662-3	4 (1.22)	3 (0.91)	2 (0.61)	3 (0.91)	2.5 (0.76)	1.5 (0.46)
1/2"	HLT4-50	11662-3	4 (1.22)	3 (0.91)	2 (0.61)	3 (0.91)	2.5 (0.76)	1.5 (0.46)
1/2"	HS4RP-50	11662-3	3.5 (1.07)	2.5 (0.76)	2 (0.61)	3 (0.91)	2 (0.61)	1.5 (0.46)
1/2"	HST4-50	11662-3	3.5 (1.07)	2.5 (0.76)	2 (0.61)	3 (0.91)	2 (0.61)	1.5 (0.46)
1/2"	HT4-50	11662-3	6 (1.83)	5 (1.52)	3.5 (1.07)	6 (1.83)	4 (1.22)	3 (0.91)
1/2"	HJ4-50	11662-3	6 (1.83)	6 (1.83)	4 (1.22)	6 (1.83)	6 (1.83)	3 (0.91)
7/8"	LDF5-50A	11662-2	6 (1.83)	5.5 (1.68)	4.5 (1.37)	5 (1.52)	4.5 (1.37)	3.5 (1.07)
7/8"	HJ5-50	11662-2	6 (1.83)	6 (1.83)	6 (1.83)	6 (1.83)	6 (1.83)	5 (1.52)
7/8"	HJ5-75	11662-2	6 (1.83)	6 (1.83)	6 (1.83)	6 (1.83)	6 (1.83)	5 (1.52)
7/8"	HT5-50	11662-2	6 (1.83)	6 (1.83)	6 (1.83)	6 (1.83)	6 (1.83)	5.5 (1.68)
1-1/4"	LDF6-50	33948-5	6 (1.83)	6 (1.83)	6 (1.83)	6 (1.83)	6 (1.83)	6 (1.83)
1-5/8"	HJ7-50A	33948-3	6 (1.83)	6 (1.83)	5.5 (1.68)	6 (1.83)	6 (1.83)	4.5 (1.37)
1-5/8"	LDF7-50A	33948-3	6 (1.83)	6 (1.83)	6 (1.83)	6 (1.83)	6 (1.83)	6 (1.83)
2-1/4"	HJ12-50	33948-6	6 (1.83)	6 (1.83)	6 (1.83)	6 (1.83)	6 (1.83)	6 (1.83)
2-1/4"	LDF12-50	33948-6	6 (1.83)	6 (1.83)	6 (1.83)	6 (1.83)	6 (1.83)	6 (1.83)
3"	HJ8-50B	33948-2	6 (1.83)	6 (1.83)	6 (1.83)	6 (1.83)	6 (1.83)	6 (1.83)
4"	HJ11-50	33948-4	6 (1.83)	6 (1.83)	6 (1.83)	5 (1.52)	5 (1.52)	4.5 (1.52)
5"	HJ9-50	33948-1	4.5 (1.37)	4.5 (1.37)	4.5 (1.37)	3 (0.91)	3 (0.91)	3 (0.91)
5"	HJ9HP-50	33948-1	4.5 (1.37)	4.5 (1.37)	4.5 (1.37)	3 (0.91)	3 (0.91)	3 (0.91)

Definitions and Assumptions 1. Per EIA-222 Standard: Coefficient of drag for coaxial cable is 1.2 (cylindrical members). Ice forms completely around member (360 degrees). Combined wind and ice loading is reduced by 25% to reflect lower probability of wind and ice occurring simultaneously. 2. Wind speeds are maximum, which includes gust factors and exposure factors.



The maximum spacing recommendations assume that all hangers are properly installed and tightened. Recommendations for a 150 ft (46 m) tower with 125 mph (200 km/h) wind speed and 1/2" radial ice (typical conditions) are highlighted in red. See "Hanger Spacing Considerations," page 593 for further information.

Click-On Hangers – Recommended Maximum Hanger Spacing

Cable Size	Cable Type Number	Hanger Type* and Stack Configuration	Recommended Maximum Hanger Spacing, feet (meters)					
			85 mph (137 km/h)			100 mph (160 km/h)		
Wind Speed:			No Ice	1/2" (13 mm)	1" (25 mm)	No Ice	1/2" (13 mm)	1" (25 mm)
Radial Ice:			No Ice	1/2" (13 mm)	1" (25 mm)	No Ice	1/2" (13 mm)	1" (25 mm)
1/2"	LDF4-50A	L4CLICK, 1-Stack	3 (0.91)	3 (0.91)	3 (0.91)	3 (0.91)	3 (0.91)	3 (0.91)
1/2"	LDF4-50A	L4CLICK, 2-Stack	3 (0.91)	3 (0.91)	3 (0.91)	3 (0.91)	3 (0.91)	3 (0.91)
1/2"	LDF4-50A	L4CLICK, 3-Stack	3 (0.91)	3 (0.91)	3 (0.91)	3 (0.91)	3 (0.91)	3 (0.91)
Note: These same hanger spacing recommendations apply for the other following 1/2" cable types: LDF4-75A, HL4RP-50, HLT4-50, HS4RP-50, HST4-50, HT4-50, HJ4-50								
5/8"	LDF4.5-50	L45CLICK, 1-Stack	3 (0.91)	3 (0.91)	3 (0.91)	3 (0.91)	3 (0.91)	3 (0.91)
5/8"	LDF4.5-50	L45CLICK, 2-Stack	3 (0.91)	3 (0.91)	3 (0.91)	3 (0.91)	3 (0.91)	3 (0.91)
5/8"	LDF4.5-50	L45CLICK, 3-Stack	3 (0.91)	3 (0.91)	3 (0.91)	3 (0.91)	3 (0.91)	3 (0.91)
Note: These same hanger spacing recommendations apply for the other following 5/8" cable types: HJ4.5-50								
7/8"	LDF5-50A	L5CLICK, 1-Stack	4 (1.22)	4 (1.22)	4 (1.22)	3 (0.91)	3 (0.91)	3 (0.91)
7/8"	LDF5-50A	L5CLICK, 2-Stack	4 (1.22)	4 (1.22)	4 (1.22)	3 (0.91)	3 (0.91)	3 (0.91)
7/8"	LDF5-50A	L5CLICK, 3-Stack	4 (1.22)	4 (1.22)	4 (1.22)	3 (0.91)	3 (0.91)	3 (0.91)
Note: These same hanger spacing recommendations apply for the other following 7/8" cable types: VXL5-50, HJ5-50, HJ5-75, HT5-5.								
1-1/4"	LDF6-50	L6CLICK, 1-Stack	4 (1.22)	4 (1.22)	4 (1.22)	3 (0.91)	3 (0.91)	3 (0.91)
1-1/4"	LDF6-50	L6CLICK, 2-Stack	4 (1.22)	4 (1.22)	4 (1.22)	3 (0.91)	3 (0.91)	3 (0.91)
1-1/4"	LDF6-50	L6CLICK, 3-Stack	3 (0.91)	3 (0.91)	3 (0.91)	3 (0.91)	3 (0.91)	3 (0.91)
1-5/8"	LDF7-50A	L7CLICK, 1-Stack	4 (1.22)	4 (1.22)	4 (1.22)	3 (0.91)	3 (0.91)	3 (0.91)
1-5/8"	LDF7-50A	L7CLICK, 2-Stack	3 (0.91)	3 (0.91)	3 (0.91)	3 (0.91)	3 (0.91)	3 (0.91)
1-5/8"	LDF7-50A	L7CLICK, 3-Stack	3 (0.91)	3 (0.91)	3 (0.91)	3 (0.91)	3 (0.91)	3 (0.91)
Note: These same hanger spacing recommendations apply for the other following 1 5/8" cable types: HJ7-50A								
Cable Size	Cable Type Number	Hanger Type* and Stack Configuration	125 mph (200 km/h)			150 mph (240 km/h)		
			No Ice	1/2" (13 mm)	1" (25 mm)	No Ice	1/2" (13 mm)	1" (25 mm)
Wind Speed:			No Ice	1/2" (13 mm)	1" (25 mm)	No Ice	1/2" (13 mm)	1" (25 mm)
Radial Ice:			No Ice	1/2" (13 mm)	1" (25 mm)	No Ice	1/2" (13 mm)	1" (25 mm)
1/2"	LDF4-50A	L4CLICK, 1-Stack	3 (0.91)	3 (0.91)	3 (0.91)	2 (0.61)	2 (0.61)	2 (0.61)
1/2"	LDF4-50A	L4CLICK, 2-Stack	3 (0.91)	3 (0.91)	3 (0.91)	2 (0.61)	2 (0.61)	2 (0.61)
1/2"	LDF4-50A	L4CLICK, 3-Stack	3 (0.91)	3 (0.91)	3 (0.91)	2 (0.61)	2 (0.61)	2 (0.61)
Note: These same hanger spacing recommendations apply for the other following 1/2" cable types: LDF4-75A, HL4RP-50, HLT4-50, HS4RP-50, HST4-50, HT4-50, HJ4-50								
5/8"	LDF4.5-50	L45CLICK, 1-Stack	3 (0.91)	3 (0.91)	3 (0.91)	2 (0.61)	2 (0.61)	2 (0.61)
5/8"	LDF4.5-50	L45CLICK, 2-Stack	3 (0.91)	3 (0.91)	3 (0.91)	2 (0.61)	2 (0.61)	2 (0.61)
5/8"	LDF4.5-50	L45CLICK, 3-Stack	2 (0.61)	2 (0.61)	2 (0.61)	2 (0.61)	2 (0.61)	2 (0.61)
Note: These same hanger spacing recommendations apply for the other following 5/8" cable types: HJ4.5-50								
7/8"	LDF5-50A	L5CLICK, 1-Stack	3 (0.91)	3 (0.91)	3 (0.91)	2 (0.61)	2 (0.61)	2 (0.61)
7/8"	LDF5-50A	L5CLICK, 2-Stack	3 (0.91)	3 (0.91)	3 (0.91)	2 (0.61)	2 (0.61)	2 (0.61)
7/8"	LDF5-50A	L5CLICK, 3-Stack	2 (0.61)	2 (0.61)	2 (0.61)	2 (0.61)	2 (0.61)	2 (0.61)
Note: These same hanger spacing recommendations apply for the other following 7/8" cable types: VXL5-50, HJ5-50, HJ5-75, HT5-50								
1-1/4"	LDF6-50	L6CLICK, 1-Stack	3 (0.91)	3 (0.91)	3 (0.91)	2 (0.61)	2 (0.61)	2 (0.61)
1-1/4"	LDF6-50	L6CLICK, 2-Stack	3 (0.91)	3 (0.91)	3 (0.91)	2 (0.61)	2 (0.61)	2 (0.61)
1-1/4"	LDF6-50	L6CLICK, 3-Stack	2 (0.61)	2 (0.61)	2 (0.61)	2 (0.61)	2 (0.61)	2 (0.61)
1-5/8"	LDF7-50A	L7CLICK, 1-Stack	3 (0.91)	3 (0.91)	3 (0.91)	2 (0.61)	2 (0.61)	2 (0.61)
1-5/8"	LDF7-50A	L7CLICK, 2-Stack	2 (0.61)	2 (0.61)	2 (0.61)	2 (0.61)	2 (0.61)	2 (0.61)
1-5/8"	LDF7-50A	L7CLICK, 3-Stack	2 (0.61)	2 (0.61)	2 (0.61)	2 (0.61)	2 (0.61)	2 (0.61)
Note: These same hanger spacing recommendations apply for the other following 1 5/8" cable types: HJ7-50A.								

* These hanger spacings have been specified based on using the Click-On hangers with Andrew specified hardware kits.

Definitions and Assumptions 1. Per EIA-222 Standard: Coefficient of drag for coaxial cable is 1.2 (cylindrical members). Ice forms completely around member (360 degrees). Combined wind and ice loading is reduced by 25% to reflect lower probability of wind and ice occurring simultaneously. 2. Wind speeds are maximum, which includes gust factors and exposure factors.

Hangers and Cable Ties

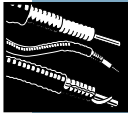

HELIAX® Coaxial Cables

Andrew offers a wide variety of hangers and cable ties for reliable and convenient support of HELIAX® coaxial cables.

- **Standard Hangers** feature great strength and long term reliability. They are ideal for general purpose use.
- **Insulated Hangers** are for use on insulated towers.
- **Snap-In Hangers** offer quickest and easiest installation for cable sizes 1/2" to 2-1/4".
- **Click-On Hangers** support two cables and are stackable up to three high (six cables). They are easy to install and are ideal for towers with limited space.
- **KwikClamp™ Hangers** attach one, two or three cable runs to a tower without the need for adapters or drilling holes.
- **Nylon Cable Ties** are lowest cost for cables 1/2" and smaller. They are ideal for 1/4" and 3/8" cable and for temporary installations.
- **Velcro* Cable Ties** are the easiest way to organize jumpers within and between radio cabinets.

* Velcro is a registered trademark of Velcro Industries.

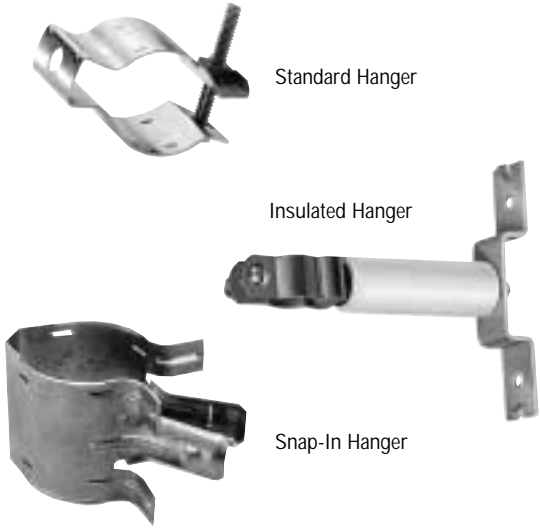

Standard Hanger

Insulated Hanger

Snap-In Hanger



Click-On Hangers

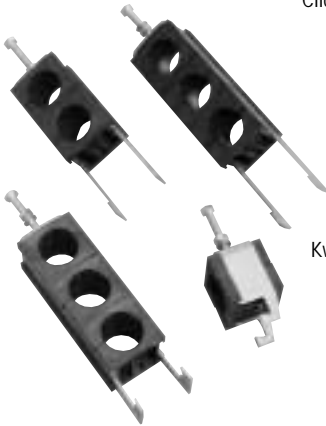

KwikClamp Hangers



Cable Ties

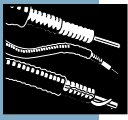

Standard Hangers and Adapters

Cable Gripping Tabs – Prevent cable slippage without the need for a permanently installed hoisting grip.

Pre-Assembled and Captivated Hardware – Eliminates the need for field assembly.

Springlike Flexibility – Makes it easy to form the hanger around the cable and dampens vibration for long life.

Heavy Gauge Stainless Steel Construction – High strength and excellent corrosion resistance for long-term reliability.

Standard HELIAX hangers are designed for easy installation. The clamp locking bolt and nut are preassembled and captivated to minimize installation labor. Proper tension is easy to determine. The hanger is simply tightened until there is a 5/16" gap between the clamp legs. The pre-drilled hole for 3/8" or 1/2" mounting hardware and slots for round member adapter clamps further simplify installation. Many accessories are available to adapt these hangers to most tower configurations.

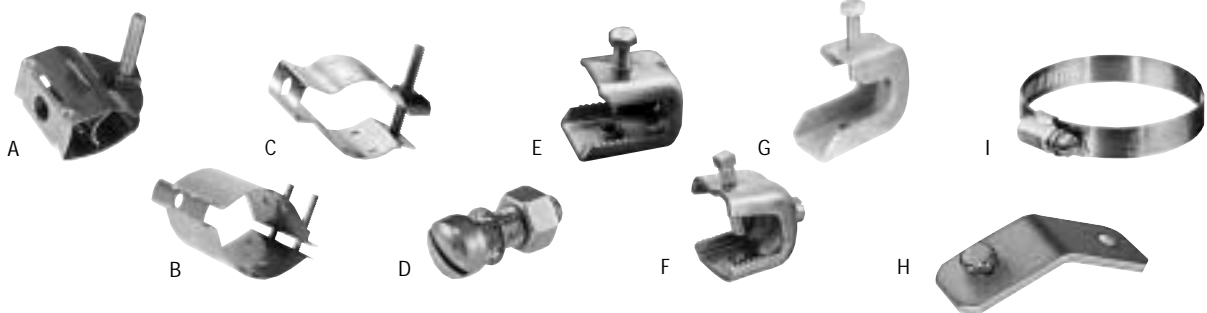

Standard Hangers and Adapters for 1/2" to 4" Cables

Hangers for 1/2" to 4" HELIAX® cables use 3/8" hardware for attachment to towers or adapters.

Hanger Kit of 10 pieces. Stainless steel. 3/8" mounting hardware not included.

Cable Size	Maximum Spacing	Photo Ref.	Type Number
1/2"	Refer to table on page 594	A	43211A
5/8"		B	42396A-9
7/8"		B	42396A-5
1-1/4"	page 594	B	42396A-1
1-5/8"		B	42396A-2
2-1/4"	B	42396A-4	
3"	C	31766A-11	
4"	C	31766A-10	

D Hardware Kit of 10 sets. 3/8" fillister-head bolts, lock washers and nuts for attachment of hangers to drilled tower members.

3/4" (19 mm) longType **31769-5**
 1" (25 mm) longType **31769-1**

E Compact Angle Adapters, Stainless Steel. The adapters are suitable for use with single runs of HELIAX cable up to 2-1/4" diameter. When used with our stackable, Click-On hangers, they can accommodate up to six runs of LDF6 (1-1/4") or smaller and up to four runs of LDF7 (1-5/8") HELIAX cables.

3/8" HardwareType **243684**
 Metric HardwareType **243684-M**

F Angle Adapter, Stainless Steel, kit of 10 pieces. For mounting cable 1/2" to 4" cable hangers to angle tower members up to 7/8" (22mm) thick. Includes hanger attachment hardware. See page 570 for bulk packs
 3/8" HardwareType **31768A**
 Metric HardwareType **31768A-M**

G Angle Adapter, Galvanized, kit of 10 pieces. For mounting cable 1/2" to 2-1/4" cable hangers to angle tower members up to 3/4" (19 mm) thick. Includes hanger attachment hardware.
 3/8" Hardware, kit of 10Type **242774**
 Metric Hardware, kit of 10Type **242774-M**

H 45° Adapter Kit of 10. Use with angle adapter and threaded rod support kit to place a hanger at a waveguide bend. Galvanized steelType **42334**

I Round Member Adapter Kit of 10 pieces. Stainless steel clamps to mount 1/2" to 4" cable hangers to round support members. Two each are needed for 3" and 4" cable hangers.

Member Diameter, in (mm)	Type Number
1 - 2 (25 - 50)	31670-1
2 - 3 (50 - 75)	31670-2
3 - 4 (75 - 100)	31670-3
4 - 5 (100 - 125)	31670-4
5 - 6 (125 - 150)	31670-5
6 - 8 (150 - 200)	31670-6

Standard Hangers and Adapters

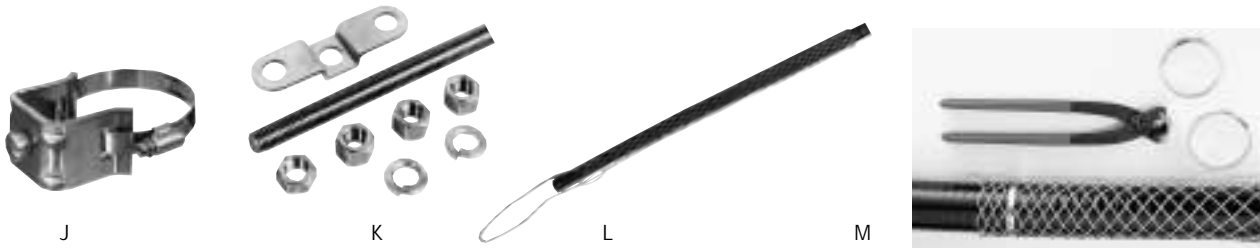
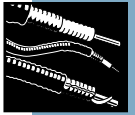

J Tower Standoff Kit of 10 pieces. Adapters with round member clamps and hardware for 1/2" to 4" hangers. All parts are stainless steel or galvanized.

Member Diameter in (mm)	1 in (25 mm) Standoff	2.5 in (60 mm) Standoff
0.75 - 1.5 (20 - 40)	30848-5	-
1.5 - 3.0 (40 - 75)	30848-4	-
3 - 4 (75 - 100)	30848-1	41108A-1
4 - 5 (100 - 125)	30848-2	41108A-2
5 - 6 (125 - 150)	30848-3	41108A-3

K Threaded Rod Support Kit. Use to mount hangers away from supporting structure, under cable bridge and inside equipment room. Includes 3/8" diameter threaded rod, galvanized ceiling mounting plate, nuts and washers. Attach to angle tower members with 31768A angle adapters. Attach to round tower members with 30848 series tower standoffs. All components are stainless steel, except ceiling mounting plate.

Rod Length in (mm)	Kit of 1	Kit of 5
12 (305)	31771	31771-4
24 (610)	31771-9	31771-6
36 (915)	-	31771-10

L Hoisting Grip. Use at 200 ft (60 m) intervals to raise cable on tower. Use with optional support clamp to achieve optimum cable grip.

Cable Size	Hoisting Grip Type Number	Optional Support Clamp Type Number
1/2"	43094	F4SGRIP-4IK
5/8"	29958	L45SGRIP-45IK
7/8"	19256B	L5SGRIP-5IK
1-1/4"	29961	L6SGRIP-6IK
1-5/8"	24312A	L7SGRIP-7IK
2-1/4"	31535	L12SGRIP-12IK
3"	26985A	-
4"	34759	-
5"	31031-1	-

M Support/Hoisting Grip. Use at 200 ft (60 m) intervals to raise cable and provide permanent cable support. Basic kit includes one grip and one support clamp. Support clamps are also available in kits of 10. Installation tool is requiredType SG-IT

For Cable Type	Grip with One Clamp	Support Clamp Kit of 10
1/4" FSJ1	F1SGRIP	F1SGRIP-11K
1/4" LDF1	L1SGRIP	L1SGRIP-11K
3/8" EFX2	E2SGRIP	E2SGRIP-21K
3/8" LDF2	L2SGRIP	L2SGRIP-21K
3/8" FSJ2	F2SGRIP	F2SGRIP-21K
1/2" FSJ4	F4SGRIP	F4SGRIP-41K
1/2" LDF4	L4SGRIP	L4SGRIP-41K
5/8" LDF4.5	L45SGRIP	L45SGRIP-45IK
7/8" LDF5/VXL5	L5SGRIP	L5SGRIP-51K
1-1/4" LDF6/VXL6	L6SGRIP	L6SGRIP-61K
1-5/8" LDF7/VXL7	L7SGRIP	L7SGRIP-71K
2-1/4" LDF12	L12SGRIP	L12SGRIP-121K

Standard Hangers and Adapters for 5" Cables

Hangers for 5" HELIXAX® cables use 1/2" hardware for attachment to towers or adapters.

Hanger Kit of 10 pieces. Galvanized steel. 1/2" mounting hardware not included. Refer to page 594 for maximum spacingType **33598-5**

A Hardware Kit of 10 pieces 1/2" x 1-1/4" (32 mm) bolts, lockwashers, and nuts for attachment of 5" hangers to drilled tower membersType **31769-4**

B Angle Adapter Kit of 10 pieces. Stainless steel. For mounting 5" cable hangers to angle tower members up to 7/8" (22 mm) thickType **33981A-1**



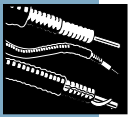

Insulated Hangers and Adapters

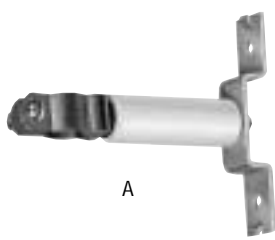

A



B

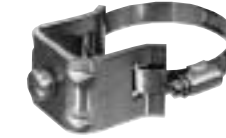

C



D



E



F



G



H

A Insulated Hanger for 1/4" to 7/8" Cables, Single. For use on insulated tower. Refer to tables on pages 596 and 597 for maximum spacing.

For 1/4", 3/8" and 1/2" cablesType **11662-3**
 For 7/8" cableType **11662-2**

B Insulated Hanger for 1-1/4" - 5" Cables Single. For use on insulated tower.

Cable Size	Max. Spacing	Type Number
1-1/4"	Refer to	33948-5
1-5/8"	tables on pages 596 and 597.	33948-3
2-1/4"		33948-6
3"		33948-2
4"		33948-4
5"		33948-1

C Round Member Adapter/Tower Standoff Kit of 10 pieces. For mounting 5" cable hangers to round support members. HELIAX® cable to clear tower leg flanges. Provides 2.5 in (60 mm) standoff. All parts are stainless steel or galvanized.

Member Diameter, in (mm)	Type Number
3 - 4 (75 - 100)	43130-1
4 - 5 (100 - 125)	43130-2
5 - 6 (125 - 150)	43130-3

D Threaded Rod Support Kit of 5 pieces. 1/2" x 12" (305 mm) threaded rods, ceiling mounting plates, nuts and washers for suspending 5" cable hangers. All parts are stainless steel except galvanized ceiling mounting plateType **31771-5**

Angle Adapter Single. For insulated hangers. Maximum member thickness 7/8 in (22 mm).

E For 1/2" and 7/8" cableType **40430-1**
F For 1-1/4" - 5" cableType **13555A**

G Round Member Adapter Single. For use with Type 33948 series (1-1/4"-5" cables) insulated hangers. Fits member diameters 1-3 in (25 - 75 mm).Type **13550**

H Stainless Steel Wraplock 100 feet complete with fasteners. Use to attach 1/4" - 7/8" insulated hangers to round members. Not to be used to attach cable or waveguide directly to towers.....Type **12395-1**

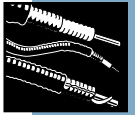

Snap-In Hangers and Adapters

Snap-In Hangers

Attach Without Hardware

Quick and easy attachment in all types of weather. The hangers snap directly into holes in the tower support members (patents pending). Installation time and cost are substantially reduced.

Heavy Gauge Stainless Steel Construction

High strength and excellent corrosion resistance for long-term reliability.

Snap-In hangers are ideal for microwave, cellular, PCS/PCN, and land mobile radio systems. They are available for 1/2" to 2-1/4" size coaxial cables.

The hanger is designed to be installed into 3/4" holes in support structures 0.120 to 0.150 inch thick. Ergonomically designed for easy installation, the hanger's retention tabs make the hanger highly resistant to pull. The hanger is mounted directly to tower support members by inserting its retention tabs into pre-punched holes in cable support systems.



Snap-In hangers can be used on any tower, by using the specially designed adapters described below. Guyed tower transmission support systems can also accommodate Snap-In hangers, when specified. Made of heavy gauge stainless steel. For hanger spacing recommendations, refer to page 595.

Kit of 10 Hangers

Cable Size	Type Number
1/2"	206706-1
5/8"	206706A-6
7/8"	206706-2
1-1/4"	206706-3
1-5/8"	206706-4
2-1/4"	206706-5

Snap-In Adapters

A Tower/Hanger Adapter cable support attaches to existing angle tower members. Includes angle support pre-punched with 3/4" and 7/16" holes to accommodate Snap-In hanger, and standard hanger.

Number of Cable Runs	J-Bolt or Angle Adapter Connections Required	Type No.
1	1	206929-1
4	2	206929-4
8	3	206929-8

B J-Bolt Hardware, Kit of 10 for attaching Tower/Hanger Adapter to 1-1/4" to 2-3/4" (32-70 mm) angle tower members. Includes J-bolt, flat washers, lock washers and nutsType **206930**

C Angle Adapter, Kit of 10. For attaching Tower/Hanger Adapter to angle tower members. Stainless Steel, 3/8" hardwareType **31768A**

D Cluster Mount**. Octagonal cable support for one to seven cable runs attaches to 1-1/2" nominal steel pipe or 1.90" (48 mm) round tower members. Pre-punched with 3/4" and 7/16" holes to accommodate snap-in hangers and standard hangers. Supplied mounting hardware kit includes 3/8" plated bolts, flat washers, lock washers and nuts.

Kit of 1Type **207030**

Kit of 10Type **207030-2**



A

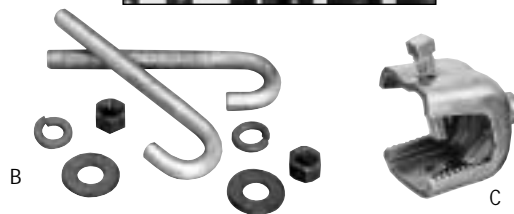

B



C



D

** Patented United States 4,813,639

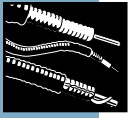

Snap-In Adapters

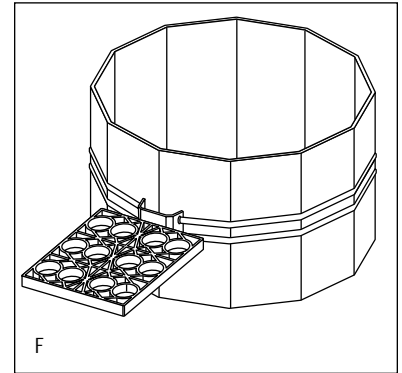
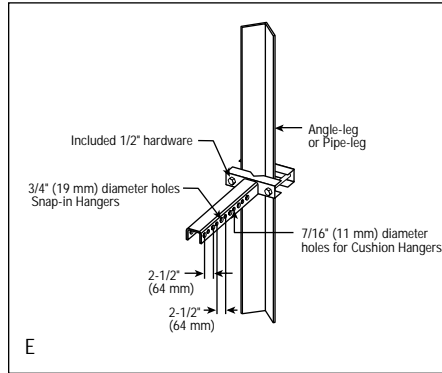
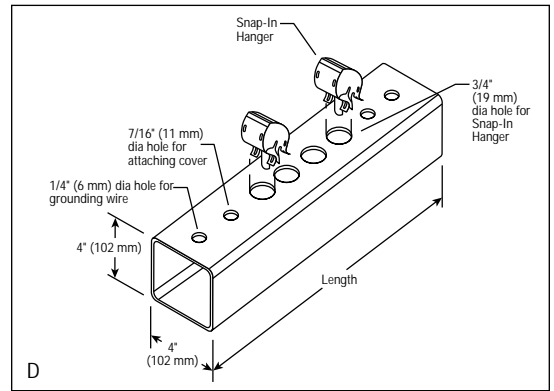
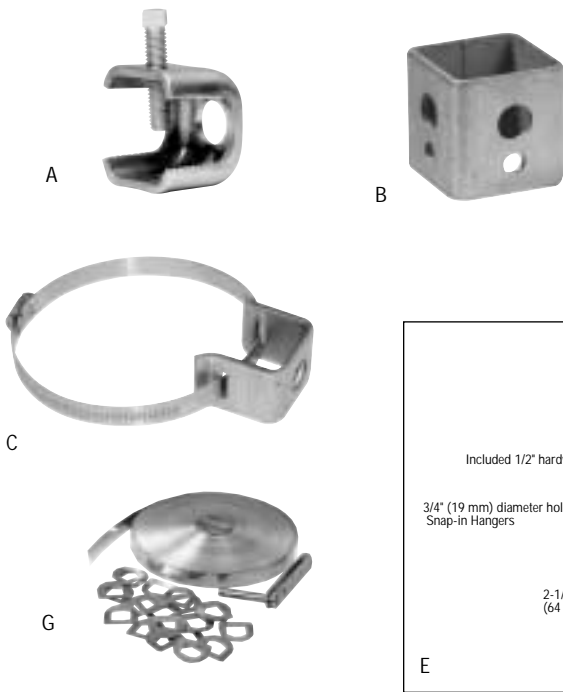

A Snap-In Angle Adapter Kit of 10 pieces. Includes 3/4" pre-punched hole for mounting snap-in hangers to angle tower members. Stainless steel, 3/8" hardwareType **SAA**

B Snap-In Adapter Block Kit of 10 pieces. Mounts up to three snap-in hangers. Attach to tower using Type 31768A angle adapter or tower standoffs. Mechanically galvanized hardwareType **SHA3**

C Snap-In Tower Standoffs Kit of 10 pieces. Mounts snap-in hangers to round tower members and provides 2-1/2 in (64 mm) standoff. Includes 3/4" pre-punched hole. All parts stainless steel or galvanized.

Member Diameter, in (mm)	Type
1-2 (25-50)	STS-12
2-3 (50-75)	STS-23
3-4 (75-100)	STS-34
4-5 (100-125)	STS-45

D PVC Roof Sleeper, supports rooftop coax runs. Constructed of gray, UV resistant PVC. 4 in x 4 in (102 mm x 102 mm).

Number of Cable Runs	Dimensions, in (mm)	Type No.
4	22 (559)	RTA-B1598
8	31.9 (810)	RTA-B1599
12	43.4	RTA-B1600

E Universal Snap-In Brackets for both angle and round tower members. Pre-punched with 3/4" holes to mount up to twelve snap-in hangers. Galvanized steel.

Angle Member	Round Member Diameter	Type No.
2-1/2" to 4"	1-1/2" to 5-9/16"	HAA-B2249
5" to 6"	6" to 8-5/8"	HAA-B2250
8"	10-3/4" to 12-3/4"	HAA-B2251

F Snap-In Adapter Brackets for large round members, water towers, or on the outside of a monopole. Mount up to three cable runs and are compatible with both snap-in and standard hangers. Use multiple brackets for additional runs. Use in conjunction with wraplock. The brackets slide on the wraplock.
.....Type **HAA-B2391**

G Stainless Steel Wraplock 100 feet complete with fasteners. Use to attach 1/4" - 7/8" insulated hangers to round members. Not to be used to attach cable or waveguide directly to towers.....Type **12395-1**

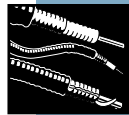

Install Cable with One Easy "Click"

Click-on Hangers* are specifically designed to support HELIAX® coaxial cable. They are stackable, install in just minutes, and provide a perfect fit that gives your PCS/PCN, cellular, microwave, rural telephony, GSM, or other telecommunications system a professional appearance, especially in confined spaces. The hangers are made of tough, UV-resistant material and set the standard for durability, simplicity of installation, and cost-effectiveness. Only two wrenches are required for installation. Refer to table on page 598 for maximum spacing.

*Patented United States No. 5794897

Click-On Hangers Ordering Information – Kits of 10

Cable Size	Cable Type	Hanger Type Number
1/2"	LDF4-50A	L4CLICK
5/8"	LDF4.5-50A	L45CLICK
7/8"	LDF5-50A	L5CLICK
1-1/4"	LDF6-50	L6CLICK
1-5/8"	LDF7-50A	L7CLICK

Click-On Hanger Hardware Kits

Click-On hanger attachment hardware is available in 3/8" or M10 sizes. Constructed of stainless steel for durability. Select hardware length according to planned hanger stack height.

Hardware Kit Ordering Information

Cable Size	Stack Height (Hangers)	Type Number M10 Kit	Type Number 3/8" Kit
1/2", 5/8" or 7/8" Cable			
	1	243095-11	243095-9
	2	243095-7	243095-5
	3	243095-3	243095-1
1-1/4" or 1-5/8" Cable			
	1	243095-12	243095-10
	2	243095-8	243095-6
	3	243095-4	243095-2

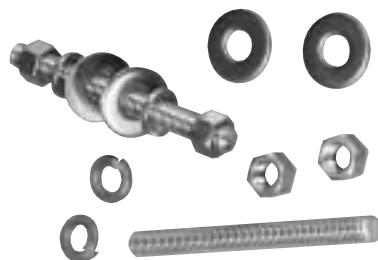

Tower and Pole Adapters

The round pole adapter attaches Click-On hangers to round member diameters 7-1/2 to 10 in (190-250 mm). Attachment hardware is sold separately. For wood poles, use lag screws. For metal poles, use Wraplock.

Adapter Ordering Information

Description	Type No.
Round Member Adapter, universal, kit of 10	244338
Compact Angle Adapter, kit of 10	
3/8" Hardware	243684
M10 Hardware	243684-M
Ceiling Adapter	244350
Stainless Steel Wraplock, 100 ft (305 m)	12395-1

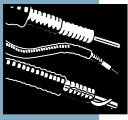

Click-On Hangers and Adapters

Flat Member Attachment

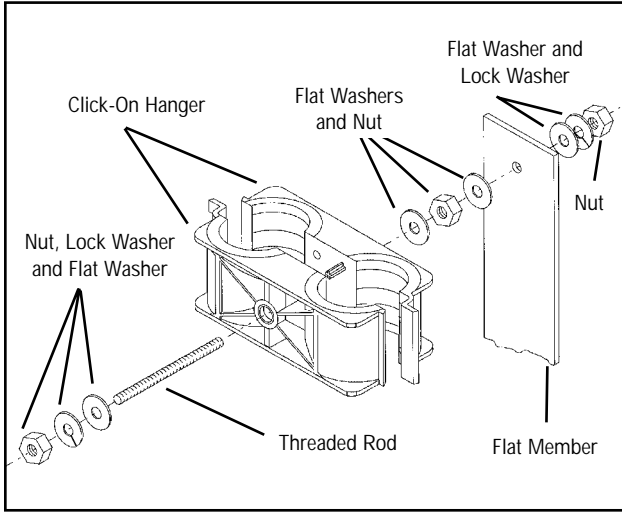

Angle Adapter Attachment

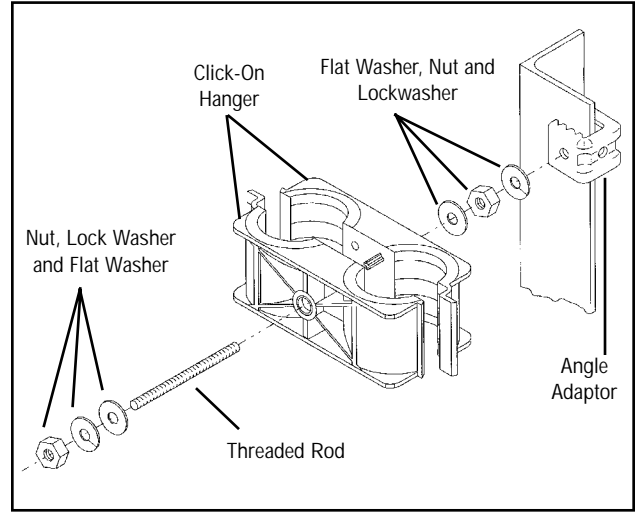

Round Adapter Attachment

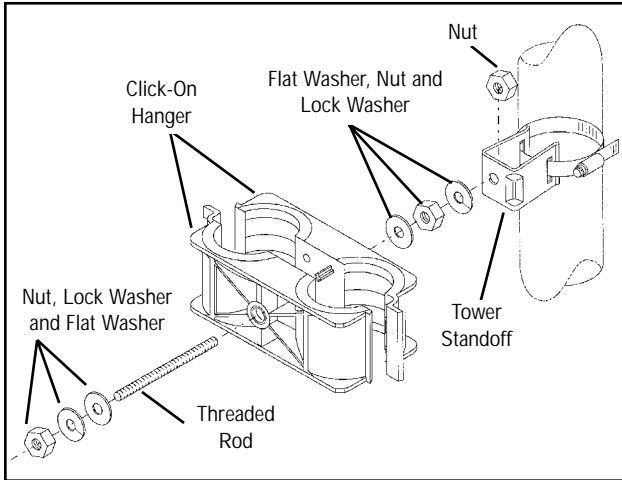

Ceiling Adaptor Attachment

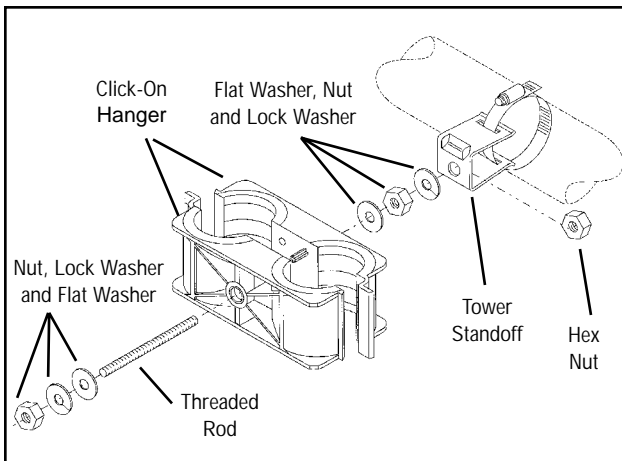
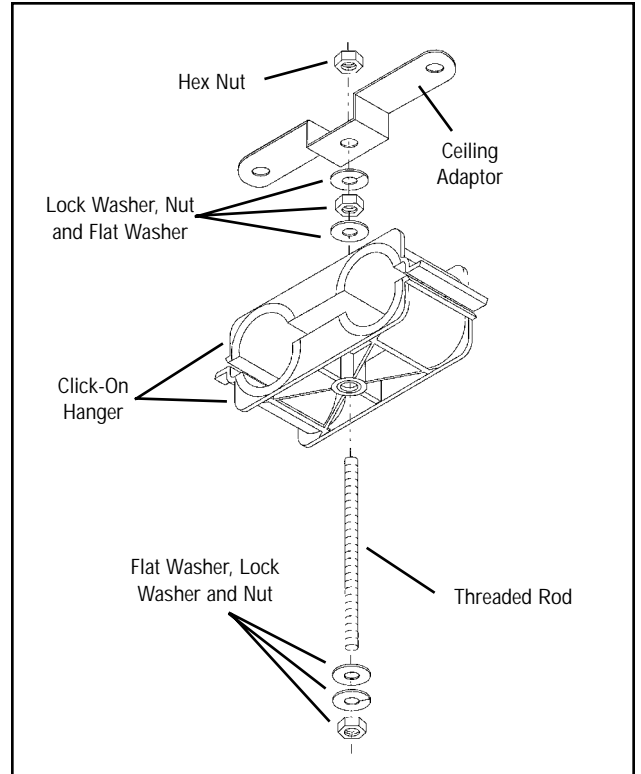

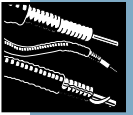

Install Multiple Cable Runs in a Limited Space.

KwikClamp hangers attach one, two or three cable runs to a tower without the need for adapters or drilling holes.

They are ideal for use on crowded towers. These self-clamping hangers attach directly to angle, round, flat, or channel tower members, providing sturdy, reliable, long-term support.

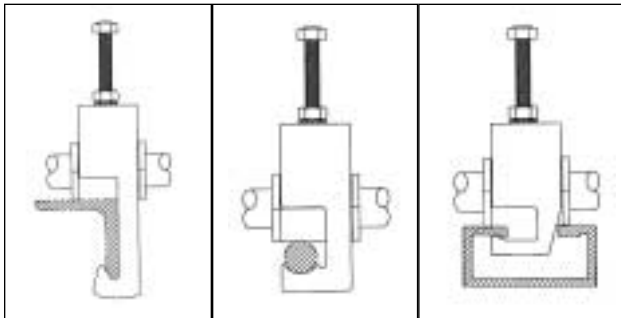
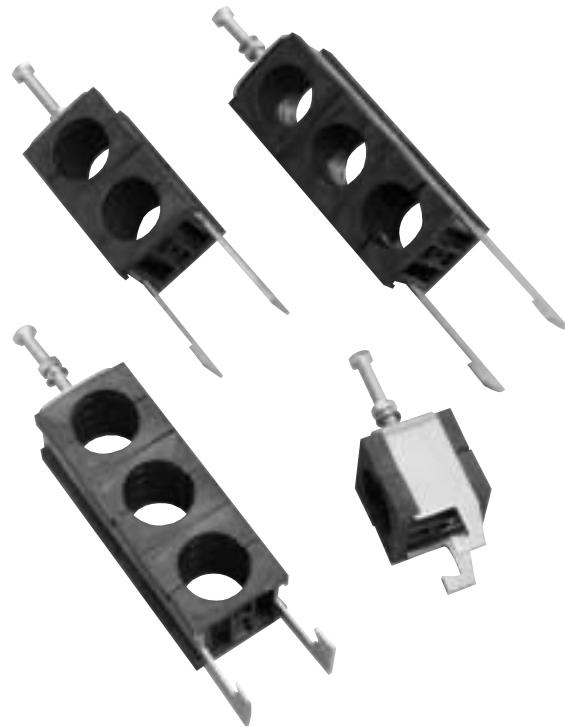

Angle KwikClamp Round/Flat KwikClamp Channel KwikClamp

KwikClamp Hanger Ordering Information

Tower Member Type	Number of Runs	1/2" LDF Type No.	5/8" LDF Type No.	7/8" LDF/VXL Type No.	1-1/4" LDF Type No.	1-5/8" LDF Type No.
8-23 mm Round or 2-23 mm Flat Plate	1	L4CLAMP-RDN-1	L45CLAMP-RDN-1	L5CLAMP-RDN-1	L6CLAMP-RDN-1	L7CLAMP-RDN-1
	2	L4CLAMP-RDN-2	L45CLAMP-RDN-2	L5CLAMP-RDN-2	L6CLAMP-RDN-2	L7CLAMP-RDN-2
	3	L4CLAMP-RDN-3	L45CLAMP-RDN-3	L5CLAMP-RDN-3	L6CLAMP-RDN-3	L7CLAMP-RDN-3
40 mm Angle	1	L4CLAMP-ANG40-1	L45CLAMP-ANG40-1	L5CLAMP-ANG40-1	L6CLAMP-ANG40-1	L7CLAMP-ANG40-1
	2	L4CLAMP-ANG40-2	L45CLAMP-ANG40-2	L5CLAMP-ANG40-2	L6CLAMP-ANG40-2	L7CLAMP-ANG40-2
	3	L4CLAMP-ANG40-3	L45CLAMP-ANG40-3	L5CLAMP-ANG40-3	L6CLAMP-ANG40-3	L7CLAMP-ANG40-3
50 mm Angle	1	L4CLAMP-ANG50-1	L45CLAMP-ANG50-1	L5CLAMP-ANG50-1	L6CLAMP-ANG50-1	L7CLAMP-ANG50-1
	2	L4CLAMP-ANG50-2	L45CLAMP-ANG50-2	L5CLAMP-ANG50-2	L6CLAMP-ANG50-2	L7CLAMP-ANG50-2
	3	L4CLAMP-ANG50-3	L45CLAMP-ANG50-3	L5CLAMP-ANG50-3	L6CLAMP-ANG50-3	L7CLAMP-ANG50-3
Channel Section 40 x 22 x 1.5 mm	1	L4CLAMP-CNL-1	L45CLAMP-CNL-1	L5CLAMP-CNL-1	L6CLAMP-CNL-1	L7CLAMP-CNL-1
	2	L4CLAMP-CNL-2	L45CLAMP-CNL-2	L5CLAMP-CNL-2	L6CLAMP-CNL-2	L7CLAMP-CNL-2
	3	L4CLAMP-CNL-3	L45CLAMP-CNL-3	L5CLAMP-CNL-3	L6CLAMP-CNL-3	L7CLAMP-CNL-3

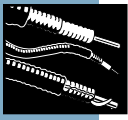

Cable Ties

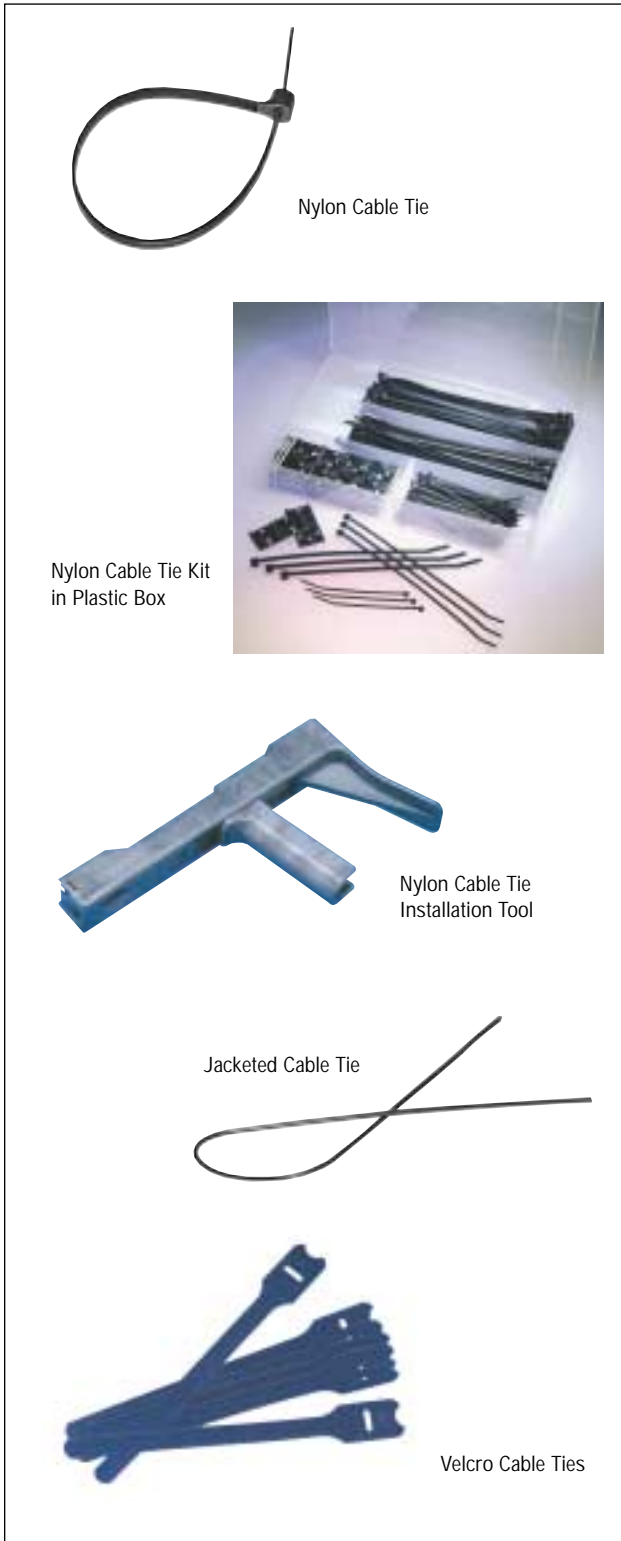

Nylon Cable Tie



Nylon Cable Tie Kit in Plastic Box

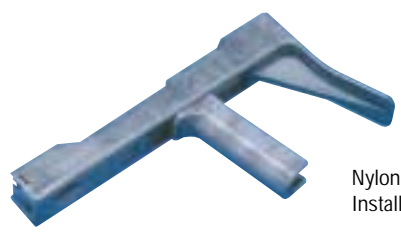

Nylon Cable Tie Installation Tool

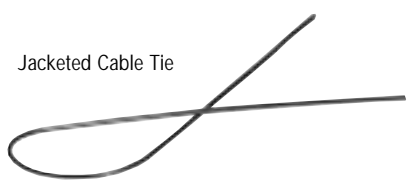

Jacketed Cable Tie



Velcro Cable Ties

Nylon Cable Tie Kit of 50 pieces. Weather-resistant straps for attaching 1/4" to 1/2" cables. Maximum spacing 3 ft (1 m) for HJ and LDF series and 18" (457 mm) for FSJ series cables.Type **40417**

Nylon Cable Tie Kit in Plastic Box. Black, weather-resistant cable ties. Kits are packaged in a reusable plastic box and organized for quick selection.

Includes:

- Quantity 100, 4" (101 mm) cable ties, 18 lb (80 N) tensile strength
- Quantity 100, 5.5" (140 mm) cable ties, 40 lb (178 N) tensile strength
- Quantity 100, 7.5" (190 mm) cable ties, 50 lb (222 N) tensile strength
- 50 adhesive-backed black mountsType **CT-K350**

Nylon Cable Tie Installation Tool. For use with Type CT-K350, above. Tightens and trims cable tie in one process with one hand. Cuts ties flush with a simple 1/4 turn downward twist. Top loading for right or left hand usersType **CT-IT**

Jacketed Cable Tie Kit of 20 pieces. Weather-resistant ties for attaching FSJ Series cable directly to tower members. Maximum spacing 18" (457 mm)Type **27290A**

Velcro* Cable Ties. The easiest way to organize inter-rack cabling. Secure in high-vibration areas. No special tying procedure required. Can be reused to accommodate future expansion. Black, 8" (203 mm) length. Maximum bundle diameter, 2" (51 mm). Minimum bundle diameter, 0.25" (6.4 mm). Tensile strength, 40 lb (178 N). For indoor use only.

- Kit of 10.....Type **VCT8-10**
- Kit of 50Type **VCT8-50**
- Kit of 100Type **VCT8-100**

* Velcro is a registered trademark of Velcro Industries.

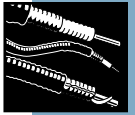

Standard Grounding Kit



SureGround™ Kit



SureGround Plus™ Kit

A well designed system uses grounding kits to provide a bond between the cable and the tower/earth ground system. One grounding kit is recommended at tower top, tower bottom, at 200 ft (60 m) intervals (where applicable), and at the entrance to the equipment shelter.

SureGround™ and SureGround Plus™ Series and 204989 and 241088 Series Grounding Kits offer:

- Solid copper construction for high current handling capability, compatibility with copper cable outer conductors, and long life.
- Meet military standards at commercial prices.
- Provide certainty of continued operation. Tested at an independent laboratory to withstand 200,000 amps.

Andrew 204989 and 241088 series solid copper grounding kits have passed United States Air Force lightning simulation tests and meet MIL-STD-188-124A. The non-braided solid copper construction of all Andrew grounding kits eliminates corrosion caused by moisture retention and "wicking." A heat shrink tube protects the cable terminal connection.

SureGround Plus Grounding kits

Transmission line grounding has never been easier. With only four parts, SureGround Plus grounding kits combine the exclusive wraparound SureGround grounding strap with a preformed rubber weatherproofing boot for fast, sure installation and neat appearance.

Heavy Duty Ground Lead

Andrew grounding kits utilize heavy duty 16 mm² ground leads to maximize performance. The IEC 1024-1 compliant copper ground lead reduces dc resistance. The extremely pliable jacket provides protection and makes it easy to maneuver the lead into position for attachment to the down conductor.

Easy Installation

Standard Grounding Kits (204989 and 241088 series) require few steps to install and include easy to follow instructions. Proper tensioning is ensured by an expansion section which provides visual indication that the strap is secured.

SureGround Grounding Kits install in less than half the time required for standard grounding kits. Factory assembled into one component, they feature a pre-formed clip-on grounding strap for easy, snap-on installation.

SureGround Plus Grounding Kits are even easier to install. Simply remove a short length of cable jacketing, snap the wraparound strap in place, slip the rubber boot into place and secure with clamps.

Kits Include

Standard Grounding Kits for 1/2" and Larger Cables.

Series 204989 and 241088 kits include a solid copper strap riveted to the grounding wire, a coiling tool for proper tightening, tower attachment hardware, and a two-part tape weatherproofing system. Field-attachable, crimp-on grounding lugs require the use of a crimping tool (not included, described below).

Standard Grounding Kit for 1/4" and 3/8" Cables.

Includes a solid copper strap, connection hardware, tower attachment hardware, and a two-part tape weatherproofing systemType 223158

SureGround Grounding Kit is a one-piece factory assembled ground strap which includes a two-part tape weatherproofing system.

SureGround Plus Grounding Kits include a factory assembled ground strap, a preformed rubber boot and two clamps.

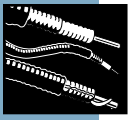

Standard Grounding Kits



Lug and Wire Length Options for Grounding Kits

Kits are available with either factory attached lugs or field attachable lugs. Standard grounding kits feature field attachable lugs that are either crimp-on or screw-on. SureGround™ grounding kits have crimp-on field attachable lugs.

One or two-hole lugs are available as indicated in the table. The holes on the two-hole lug fit common bus bar configurations with spacings of 0.750, 8.815 or 1.0 inch. All Andrew bus bars will accept both types of lugs.

Universal Grounding Lug Kit of 10.....Type 244456

Grounding wire is available in a variety of lengths as indicated in the table.

Crimping Tool. Used to attach crimp-on lugs for standard and SureGround series. Not required for kits having factory-attached lugs.Type 207270

Standard Grounding Kits

Cable Size	With Factory Attached One-Hole Lug Type No.	With Factory Attached Two-Hole Lug Type No.	With Field-Attachable Crimp-On Two-Hole Lug Type No.	Attachable Screw-On One-Hole Lug Type No.
Grounding Wire Length:	24 in (610 mm)	24 in (610 mm)	36 in (915 mm)	36 in (915 mm)
1/4" and 3/8"	223158	223158-2	-	-
1/2"	204989-1	241088-1	241088-6	204989-31
5/8" and 7/8"	204989-2	241088-2	241088-7	204989-32
1-1/4"	204989-3	241088-3	241088-8	204989-33
1-5/8"	204989-4	241088-4	241088-9	204989-34
2-1/4" and 3"	204989-5	241088-5	241088-10	204989-35
4"	204989-6	-	-	204989-36
5"	204989-7	-	-	204989-37



SureGround™ Grounding Kits

Cable Type	Factory Attached One-Hole Lug Type No.	Factory Attached Two-Hole Lug Type No.	Field-Attachable Crimp-On One-Hole Lug Type No.	Field-Attachable Crimp-On Two-Hole Lug Type No.
600 mm (24 in) Grounding Wire				
LDF4	SGL4-06B1	SGL4-06B2	-	-
LDF45	SGL45-06B1	SGL45-06B2	-	-
LDF5	SGL5-06B1	SGL5-06B2	-	-
LDF6	SGL6-06B1	SGL6-06B2	-	-
LDF7	SGL7-06B1	SGL7-06B2	-	-
LDF12	SGL12-06B1	SGL12-06B2	-	-
1000 mm (39 in) Grounding Wire				
LDF4	SGL4-10B1	SGL4-10B2	-	-
LDF45	SGL45-10B1	SGL45-10B2	-	-
LDF5	SGL5-10B1	SGL5-10B2	-	-
LDF6	SGL6-10B1	SGL6-10B2	-	-
LDF7	SGL7-10B1	SGL7-10B2	-	-
LDF12	SGL12-10B1	SGL12-10B2	-	-
1500 mm (59 in) Grounding Wire				
LDF4	-	-	SGL4-15B3	SGL4-15B4
LDF4	-	-	SGL45-15B3	SGL45-15B4
LDF5	-	-	SGL5-15B3	SGL5-15B4
LDF6	-	-	SGL6-15B3	SGL6-15B4
LDF7	-	-	SGL5-15B3	SGL5-15B4
LDF12	-	-	SGL12-15B3	SGL12-15B4

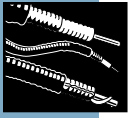

SureGround Plus™ Grounding Kits



SureGround Plus™ Grounding Kits

Cable Type	Factory Attached One-Hole Lug Type No.	Factory Attached Two-Hole Lug Type No.	Field-Attachable Crimp-On One-Hole Lug Type No.	Field-Attachable Crimp-On Two-Hole Lug Type No.
600 mm (24 in) Grounding Wire				
LDF4	SGPL4-06B1	SGPL4-06B2	-	-
LDF4.5	SGPL45-06B1	SGPL45-06B2	-	-
LDF5	SGPL5-06B1	SGPL5-06B2	-	-
LDF6	SGPL6-06B1	SGPL6-06B2	-	-
LDF7	SGPL7-06B1	SGPL7-06B2	-	-
LDF12	SGPL12-06B1	SGPL12-06B2	-	-
1000 mm (39 in) Grounding Wire				
LDF4	SGPL4-10B1	SGPL4-10B2	-	-
LDF4.5	SGPL45-10B1	SGPL45-10B2	-	-
LDF5	SGPL5-10B1	SGPL5-10B2	-	-
LDF6	SGPL6-10B1	SGPL6-10B2	-	-
LDF7	SGPL7-10B1	SGPL7-10B2	-	-
LDF12	SGPL12-10B1	SGPL12-10B2	-	-
1500 mm (59 in) Grounding Wire				
LDF4	-	-	SGPL4-15B3	SGPL4-15B4
LDF4.5	-	-	SGPL45-15B3	SGPL45-15B4
LDF5	-	-	SGPL5-15B3	SGPL5-15B4
LDF6	-	-	SGPL6-15B3	SGPL6-15B4
LDF7	-	-	SGPL7-15B3	SGPL7-15B4
LDF12	-	-	SGPL12-15B3	SGPL12-15B4

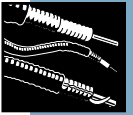

Universal Ground Bar

Mounting flexibility and central collecting point for grounding leads

This competitively priced universal ground bar offers the mounting flexibility so often needed at wireless communications sites. The solid copper bar accommodates vertical and 90 degree mounting configurations and provides a central point to collect grounding leads. It is ideal for all grounding applications, including towers and building rooftops.

Ground Bar, 1/4 x 2-1/2 x 19-1/2 inType **UGBKIT**

Ground Bar, 1/4 x 2-1/2 x 12-1/2 inType **UGBKIT-2**



Universal Arrestor Ground Bar Assembly

This pre-punched solid copper ground bar assembly simplifies mounting and grounding of surge arrestors inside the building. Instead of relying on individual wires or field-fabricated trapeze setups, the Andrew universal arrestor ground bar assembly provides a uniform mounting and grounding point for surge arrestors and grounding leads. The 1/8" copper ground bar assembly uses three horizontal members that can be oriented flat or upright, and adjusted vertically as needed to accommodate various surge arrestor types. Also included is a mounting kit which includes ceiling brackets, insulators, threaded rod, and hardware.

- Compatible with standard entry port sizes.
- Height adjustable bars.
- Solid copper construction.
- Accepts bulkhead or bolt grounded surge arrestors
- Accommodates one and two-hole grounding lugs.
- Eliminates the need for an internal buss bar.

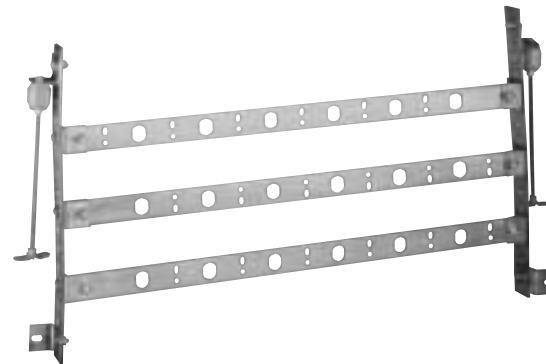

Universal Arrestor Ground Bar Assembly Ordering Information

Number of Grounding Bars	Grounding Positions Per Bar	Punched for Arrestor Types	Type Number
3	6	All APTL Series, 7-16 DIN or Bolt Grounded	UGBA-DIN-36
3	6	APG and APM Series, 7-16 DIN or Bolt Grounded	UGBA-DINU-36
3	6	N Bulkhead or Bolt Grounded	UGBA-N-36
3	4	All APTL Series, 7-16 DIN or Bolt Grounded	UGBA-DIN-34
3	4	APG and APM Series, 7-16 DIN or Bolt Grounded	UGBA-DINU-34
3	4	N Bulkhead or Bolt Grounded	UGBA-N-34



Lightning Surge Arrestors



Ordering Information

Interface Type	Type Number
For LDF5-50A, 7/8" Foam-Dielectric Cable	
Bulkhead N Female	APTL5-BNF-(*)
Bulkhead 7-16 DIN Female	APTL5-BDF-(*)
For LDF6-50, 7/8" Foam-Dielectric Cable	
Bulkhead N Female	APTL6-BNF-(*)
Bulkhead 7-16 DIN Female	APTL6-BDF-(*)
For LDF7-50A, 7/8" Foam-Dielectric Cable	
Bulkhead N Female	APTL7-BNF-(*)
Bulkhead 7-16 DIN Female	APTL7-BDF-(*)

* Frequency band. Insert Detail Number from Operating Frequencies table.

Operating Frequencies – Contact Andrew for current availability of specific frequency bands.

Frequency Band, MHz	Insertion Loss, dB	Return Loss dB, Typical	Detail Number
800-870	< 0.1	28.0	-6
824-900	< 0.1	28.0	-2
824-960	< 0.1	28.0	-1
870-960	< 0.1	28.0	-3
1700-1900	< 0.1	28.0	-11
1850-1990	< 0.1	28.0	-9

90° Mounting Bracket for APTL Series Arrestor Plus
Type **244847**

Arrestor Plus® Integrated, T-Series Lightning Surge Arrestors

The Arrestor Plus[†] Integrated, T-Series Lightning Surge Arrestor is a one-piece surge arrestor/HELIAX® connector. It uniquely combines the reliability of quarter-wave shorting stub technology with the proven performance of HELIAX connectors to deliver premium lightning protection in a single component.

The integrated design of the Arrestor Plus reduces the number of components resulting in improved system performance and reduced system cost. Silver plating and high contact pressures throughout maintain low intermodulation levels – a definite plus for today's wireless systems.

Arrestor Plus is available for 1/2", 7/8", 1-1/4", and 1-5/8" LDF cables as specified in the table.

[†] U.S. and international patents pending.

Integrated Arrestor/Connector Design

- *Insertion loss less than 0.1 dB*
- *Improved system performance*
- *Reduced component costs*
- *Easy installation*
- *Completely weatherproof*
- *RingFlare™ connector design automatically flares the cable as the connector is tightened.*

Quarter-Wave Shorting Stub Technology

- *Provides true "multi-strike" capability. Tests performed by independent laboratories verify that Arrestor Plus withstands in excess of 50 impulse current surges of 50 kA without product degradation.*
- *Reliable equipment protection*
- *Maintenance free*

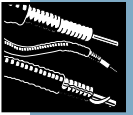

Arrestor Plus[®]

T-Series, Lightning Surge Arrestors

- Compact profile ideal for installation in tight spaces
- Reliable equipment protection
- Excellent microwave performance. Low VSWR, low insertion loss
- Fully weatherproof
- Easy installation
- Available with Type N or DIN interfaces

The new Arrestor Plus T-Series surge arrester provides excellent lightning protection and outstanding RF performance, in a compact design, that is ideal for confined applications, indoors or outdoors.

Using quarter-wave surge protection technology, this T-shaped arrester offers true multistrike protection. For an applied current impulse at 20 kA (8 x 20 waveform), the throughput energy is less than 1 mJ. Silver plated components and high pressure contacts throughout also ensure low levels of intermodulation and excellent VSWR performance. The slim profile easily fits inside equipment enclosures. It is also fully weatherproof and is suitable for a variety of outdoor applications.

The Arrestor Plus T-Series is supplied with a grounding stud which allows direct attachment to a ground lead or bus bar. Mounting flexibility is further enhanced by the variety of through hole configurations provided in the body of the arrester.

The T-Series is complemented with a full line of mounting adapters and accessories.

Ordering Information

Interface Type	Type Number
N Male/N Male	APT-NMNM-(*)
N Female/N Female	APT-NFNF-(*)
N Female/N Male, Hex	APT-NFNM-(*)
7-16 DIN Female/7-16 DIN Female	APT-DFDF-(*)
7-16 DIN Female/7-16 DIN Male	APT-DFDM-(*)

* Frequency band. Insert Detail Number from Operating Frequencies table.

Operating Frequencies

Frequency Band, MHz**	Insertion Loss, dB	VSWR Max.	Detail Number
824-960	< 0.1	1.10	-1
824-900	< 0.1	1.07	-2
870-960	< 0.1	1.07	-3
800-870	< 0.1	1.07	-6
1700-1900	< 0.1	1.07	-11
1850-1990	< 0.1	1.07	-9

** Additional frequencies available. Contact Andrew for availability.

APT Mounting Hardware

Type NType 243394
 DIN.....Type 243396



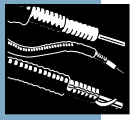

Replaceable Gas Tube Surge Arrestors



New SureFlex™ Arrestor Plus® Cable Assemblies

Both the Quarter Wave Shorting Stub (QWS) surge arrestors and broadband replaceable gas tube arrestors are available in combination with the new Sureflex cable assemblies. These cable assemblies include all the benefits of SureFlex plus the protection of an integrated Arrestor Plus surge arrester.

SureFlex cable assemblies' unique connector attachment includes a solder connection to both the inner and the outer conductors. The automated attachment process employs an induction soldering technique that ensures 360 degrees of electrical contact and a reliable weather seal. This process ensures a consistent, robust attachment every time.

The one-piece surge arrester/connector delivers premium lightning protection in a single component that is completely soldered to seal in performance and seal out the elements. SureFlex Arrestor Plus assemblies include bulkhead mounting and will fit into your base station cabinet or in building applications.

Contact Andrew to have an assembly designed for your application.

Arrestor Plus® Replaceable Gas Tube Surge Arrestors

Offering broadband performance from 0-2500 MHz and excellent electrical characteristics, Arrestor Plus Replaceable Gas Tube Surge Arrestors are easy to install and feature a dc pass capability through the center conductor to power tower-top electronics. The unit's removable cap makes periodic maintenance fast and easy.

Ordering Information

Interface Type	Gas Tube Static Sparkover Voltage	Type Number
Bulkhead 7-16 DIN Female and 7-16 DIN Female	90	APG-BDFDF-090
	230	APG-BDFDF-230
	350	APG-BDFDF-350
Bulkhead 7-16 DIN Female and 7-16 DIN Male	90	APG-BDFDM-090
	230	APG-BDFDM-230
	350	APG-BDFDM-350
Bulkhead Type N Female and Type N Female	90	APG-BNFNF-090
	230	APG-BNFNF-230
	350	APG-BNFNF-350
Bulkhead Type N Female and Type N Male	90	APG-BNFNM-090
	230	APG-BNFNM-230
	350	APG-BNFNM-350
	1000	APGHP-BNFNM-1000

Gas Tube Replacement Kit of 10

Static Sparkover Voltage	Type Number
90	GASTUBE-090
230	GASTUBE-230
350	GASTUBE-350
1000	GASTUBE-1000

90 Degree Mounting/Grounding Bracket

Interface Type	Type Number
Type N	243951
7-16 DIN	243950

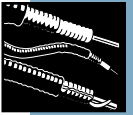

WeatherShield™ Connector Protection Housing

Easy to Install Weatherproofing in Seconds

Complete your transmission line system with the premier connector weatherproofing product. WeatherShield seals and protects connectors from the environment. It provides an additional measure of system protection by providing a watertight seal around the cable and dampening the vibration that can loosen connector interfaces.

The WeatherShield takes just seconds to install. Simply place the WeatherShield around your connection and snap in place. No heat guns or shrink tubes are required.

Cable Size to Cable Size	Type No.
VXL5 or LDF5 to LDF4	WS-L5L4
VXL5 or LDF5 to FSJ4	WS-L5F4
VXL6 or LDF6 to LDF4	WS-L6L4
VXL6 or LDF6 to FSJ4	WS-L6F4
VXL7 or LDF7 to LDF4	WS-L7L4
VXL7 or LDF7 to FSJ4	WS-L7F4



WeatherShield™ Connector Protection Housing (patent pending)

Contact Andrew for further information.

Connector/Splice Weatherproofing Kit

Includes butyl rubber tape and plastic tape to provide additional moisture protection on exposed and buried connectors and splices. It also prevents loosening of connectors at jumper cable interfaces caused by vibration.

.....Type 221213



Connector/Splice Weatherproofing Kit

HELLIAX® Coaxial Cables

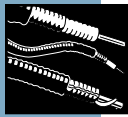

Weatherproofing

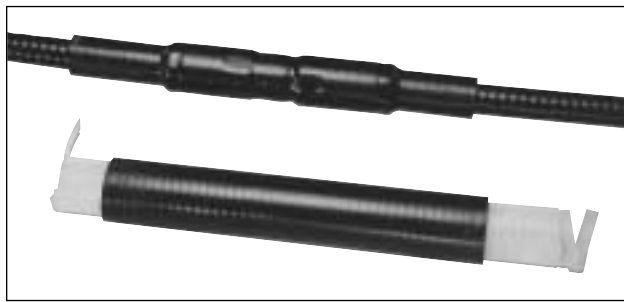

3M™ Cold Shrink™ Weatherproofing Kit

**Fast, Effective Connector
Weatherproofing in Three Minutes.**

Cold Shrink

This weatherproofing product seals and protects connectors, splices and jumper-to-antenna interfaces from the environment.

No Tools Required

Cold Shrink slips over the connection and compresses around the interface. Tapes or heat guns are not required for sealing or shrinking. Simply place the Cold Shrink kit over the cable, make the cable connection, and unwind the pull-tab applicator. Once it is collapsed, its continuous compression design forms a water tight seal around the cable.

Fits up to 2-1/4" HELIAX® Cable

The kits are available for transitions from larger to smaller diameter cable, such as 1-5/8" to 1/2", or for same diameter cable, such as 1/2" to 1/2". See the table for Type Numbers.

Available for Antenna-Jumper Interface

The kits are also ideal for weatherproofing the antenna-to-jumper interface, which is typically quite difficult to reach. Cold Shrink eliminates the needs for shrink tubes or weatherproofing tapes.

3M and Cold Shrink™ are trademarks of Minnesota Mining and Manufacturing Company.

Cable Size	Connections Per Kit
For Connector Interface	
1-5/8" to 1/2"	2
For Splices	
3", 4" and 5"	1
1-5/8" and 2-1/4"	2
1-1/4"	6
7/8"	8
1/2"	12

Ordering Information – Cold Shrink

Kit Coverage Cable Size to Cable Size	Min. Application Diameters* in (mm)	Type Number
Kits for Type N Connectors		
1-5/8"-7/8"	1.20-0.84 (30-12)	241475-3
1/2"-1/2"	0.48 (12)	241474-4
7/8"-7/8"	0.84 (21)	241474-5
1-1/4"-1-1/4"	1.20 (30)	241474-6
1-5/8"-1-5/8"	1.20 (30)	241474-6
Kits for Type N and 7-16 DIN Connectors		
5/8"-3/8"	0.80-0.41 (20-10)	241475-13
5/8"-1/2"	0.80-0.63 (20-16)	241475-13
5/8"-5/8"	0.80-0.80 (20-20)	241474-7
7/8"-1/4"	0.84-0.29 (21-7.4)	241475-12
7/8"-3/8"	0.84-0.41 (21-10)	241475-9
7/8"-1/2"	0.84 0.63 (21-16)	241475-9
1-1/4"-1/4"	1.20-0.29 (30-7.4)	241475-11
1-1/4"-3/8"	1.20-0.41 (30-10)	241475-5A
1-1/4"-1/2"	1.20-0.63 (30-16)	241475-5A
1-5/8"-1/4"	1.20-0.29 (30-7.4)	241475-11
1-5/8"-3/8"	1.20-0.41 (30-10)	241475-5A
1-5/8"-1/2"	1.20-0.63 (30-16)	241475-5A
2-1/4"-3/8"	1.40-0.41 (36-10)	241475-8
2-1/4"-1/2"	1.40-0.63 (36-16)	241475-8
Kits for Antenna Interfaces**		
1/4"-1-1/2" Omni/Panel base or Type N or DIN	0.29 (7.4) - ***	241548-10
3/8"-1-1/2" Omni/Panel base or Type N or DIN	0.41 (10) - ***	241548-8
1/2"-1-1/2" Omni/Panel base or Type N or DIN	0.41 (10) - ***	241548-8
1/4"-2" Omni/Panel base or Type N or DIN	0.29 (7.4) - ***	241548-11
3/8"-2" Omni/Panel base or Type N or DIN	0.41 (10) - ***	241548-9
1/2"-2" Omni/Panel base or Type N or DIN	0.41 (10) - ***	241548-9
1/2" LDF4 - Type N interface	0.49 (12) - ***	241548-4
5/8"-Type N or DIN interface	0.80 (20) - ***	241474-7
7/8"-Type N or DIN interface	0.49 (12) - ***	241548-5
Kits for Arrestor Plus® Surge Protectors		
7/8" LDF5 – APTL5	0.84	241474-5
1-1/4" LDF6 – APTL6	1.20	241474-6
1-5/8" LDF7 – APTL7	1.20	241474-6

* Minimum application diameter is the fully compressed diameter of each tube in the kit.

** Andrew Cold Shrink weatherproofing is completely compatible with Andrew base station antennas. Request bulletin 10138 for complete details.

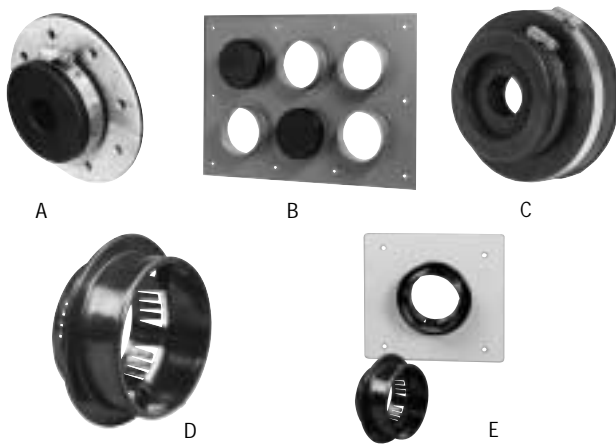
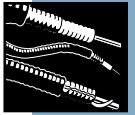

- A Single Entrance Wall/Roof Feed Thru Assembly.** Includes rubber boot, clamp and galvanized steel plate. Order from table.
- B Multiple Entrance Wall/Roof Feed Thru Plate.** Plate with one or more 4 or 5-inch entry holes. Use with the corresponding size rubber cable boots (sold separately).
- C Cable Entry Boot.** Use with above feed thru plate, with the corresponding size entry hole.

NEW!

- D SNAP-IN Entry Port.** Patent Pending. Snaps into a cabinet or metal plate, 0.06 to 0.14 in (1.5 to 3.5 mm) thick, with a 3.5 in (89 mm) diameter hole. If your cabinet or metal plate has a 4 in (100 mm) hole, use adapter plate below. Constructed from a weather-resistant engineering plastic. Use with One-Piece cable entry boot (Item C) for a durable, low cost alternative to fabricated metal entry ports.

SNAP-IN Entry Port Type **SEP-4**
 SNAP-IN Entry Port, kit of 10 Type **SEP-4-10**
 Blank Cap, 4 in (100 mm)..... Type **CAP-4**
 Blank Cap, 4 in (100 mm), kit of 10.... Type **CAP-4-10**

- E Adapter Plate.** Mounts SNAP-IN entry port (Item D) to an existing 4 in (100 mm) opening in a cabinet or metal plate, 0.06 to 0.14 in (1.5 to 3.5 mm) thick.
Type **SEPA-4**

Wall/Roof Feed Thru Assemblies, Single Entrance

Cable Size	Type Number
1/2"	40656A-3
5/8"	40656A-7
7/8"	40656A-1
1-1/4"	40656A-5
1-5/8"	40656A-2
2-1/4"	40656A-6
3"	40394-2
4"	40394-1
5"	33938-5

Multiple Entrance Wall/Roof Feed Thru Plates

Number of Openings	Height in (mm)	Width in (mm)	Opening Distance Center to Center in (mm)	Type No.
4" (102 mm) Entry Opening, Multiple Entrance Plate				
1	7 (178)	7 (178)	-	204673-1
1	5 (127)	5 (127)	-	204673-2
4	9.5 (241)	25.5 (648)	5.5 (139)	204673-4
8	17.5 (444)	25.5 (648)	5.5 (139)	204673-8
12	25.5 (648)	25.5 (648)	5.5 (139)	204673-12
16	25.5 (648)	25.5 (648)	5.5 (139)	204673-16
5" (127 mm) Entry Opening, Multiple Entrance Plate				
1	9.5 (241)	9.5 (241)	-	48940-1
2	9.5 (241)	17.5 (444)	7 (178)	48940-2
3	9.5 (241)	25.5 (648)	7 (178)	48940-3
4	17.5 (444)	17.5 (444)	7 (178)	48940-4
6	17.5 (444)	25.5 (648)	7 (178)	48940-6

One-Piece Cable Entry Boots

Cable Size	Number of Holes in Boots	Cable Boot Type No.
4" (102 mm) Cable Boots		
1/4" Foam	3	204679A-17
3/8" Foam	1	204679A-19
1/2" Foam	1	204679A-5
1/2" Foam	3	204679A-7
1/2" Foam	4	204679A-16
1/2" Air	1	204679A-6
1/2" Air	3	204679A-1
5/8"	1	204679A-13
5/8"	3	204679A-14
7/8"	1	204679A-2
7/8"	2	204679A-18
7/8"	3	204679A-15
1-1/4"	1	204679A-3
1-5/8"	1	204679A-4
2-1/4"	1	204679A-8
3"	1	204679A-9
5" (127 mm) Cable Boots		
3/8" Foam	3	48939A-16
1/2" Foam	1	48939A-6
1/2" Foam	3	48939A-8
1/2" Foam	4	48939A-17
1/2" Air	1	48939A-7
1/2" Air	3	48939A-5
5/8"	1	48939A-14
5/8"	3	48939A-15
7/8"	1	48939A-1
7/8"	3	48939A-2
1-1/4"	1	48939A-3
1-5/8"	1	48939A-4
2-1/4"	1	48939A-9
3"	1	48939A-10

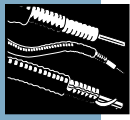

Cable Entry Systems

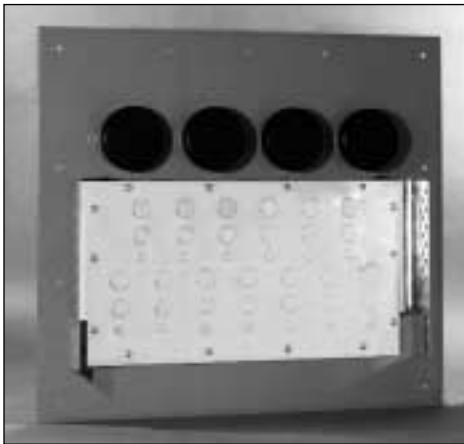

ArrestorPort™ II

The ArrestorPort™ II is the latest design offering the greatest cost savings and installation ease for wireless systems using surge arrestors.

ArrestorPort™ II Integrated Transmission Line Entry/Ground System

The ArrestorPort II integrated building entry/ground system redefines the way you achieve cable shelter entry and grounding. Traditional installations rely on a piecemeal approach that steals time and increases costs. ArrestorPort II unifies the installation of entry ports, Arrestor Plus surge protectors, and transmission line grounding into an integrated entry/ground system. Arrestor Plus cuts costs, saves valuable interior space and protects your revenues and personnel from the damaging effects of lightning strikes.

ArrestorPort™ II Kit

Wall entry and grounding system in one. Kit consists of an entry panel and a 1/8" solid copper ground bar assembly with assembly hardware, weatherstripping and weatherproof sealing caps for all entry ports. Use with Arrestor Plus® surge arrestors (page 614, order separately) and standard cable boots (page 619, order separately).

Type APORT-13-4

Provides mounting positions for 13 bulkhead mount surge arrestors and includes four 4 in holes for waveguide entry.

Type APORT-26N-4

Provides mounting positions for 26 N bulkhead mount surge arrestors and includes four 4 in holes for waveguide entry.

Cable Prep Tools



EASIX® Cable Prep Tool

EASIX® precision cutting tool is the only cutting tool made exclusively for HELIAX® coaxial cable.

It's Accurate – Cuts precisely at crest of copper corrugation at the exact distance required for easy connector attachment. Clean cut makes flaring easier than ever. Precise blade depth makes it impossible to cut inner conductor.

It's Consistent – Every cut by every technician on every interface of any cable will be exactly the same. It's one more way to ensure consistent electrical performance for your cable system.

See ordering information on page 621.

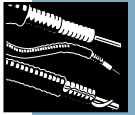

EASIAX® Plus Automated Cable Prep Tool

Now cable installers and system designers can dramatically reduce cable preparation time and expense while improving overall system performance with the EASIAX® Plus Automated Cable Preparation Tool. Fit the EASIAX Plus Tool to any standard power drill and it removes the cable jacket, outer conductor, and foam, then cuts back and chamfers the inner conductor to the correct dimensions for connector attachment – all in less than 15 seconds. The EASIAX Plus automated method of cable preparation provides cable connections that are more consistent, more reliable, and more repeatable.

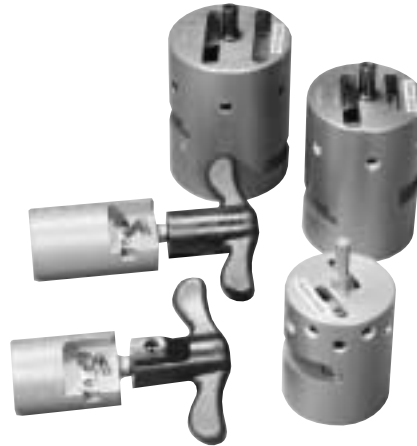

EASIAX Plus Ordering Information

Tool Type No.	For HELIAX Cable Types	Description
CPT-F4B	FSJ4	Automated tool compatible with FSJ4 Version 2 connectors only. Replacement blade kit Type Number CPT-BKS
CPT-L1	LDF1	Automated cable prep tool. Replacement blade kit Type Number CPT-BKS
CPT-E2L2DIN	EFX2, LDF2	Automated tool compatible with DIN connectors only. Replacement blade kit Type Number CPT-BKS
CPT-E2L2N	EFX2, LDF2	Automated tool compatible with N connectors only. Replacement blade kit Type Number CPT-BKS
CPT-L4ARC	LDF4	Automated tool compatible with LDF4 RingFlare(tm) connectors only. Replacement blade kit CPT-BKS
CPT-L45RC	LDF4.5	Automated cable prep tool. Replacement blade kit Type Number CPT-BKS
CPTL5A	LDF5	Automated cable prep tool compatible with standard and RingFlare™ connectors. Replacement blade kit Type Number CPT-BK5
CPTL6	LDF6	Automated cable prep tool compatible with standard and RingFlare™ connectors. Replacement blade kit Type Number CPT-BK6
CPTL7	LDF7	Automated cable prep tool compatible with standard and RingFlare™ connectors. Replacement blade kit Type Number CPT-BK7
CPT-HANDL	Manual handle 1/4" - 5/8"	

Tools for 1/4" through 1/2" recommended drill size 3/8" torque value 12 volt minimum. Cordless drill 14.4 volt minimum RPM 0-1300
 Tools for 7/8" through 1 5/8" recommended drill size 1/2". Cordless drill 15.4 volt minimum RPM 0-850.

EASIAX Cutting Tool Ordering Information

For HELIAX® Cable Types	Cutting Tool Type No.	Features	Replacement Blades Kit of 5, Type No.
FSJ1†, FSJ4‡, ETS1, RXL1* Series	207865	Cuts jacketing and outer conductor	209874
FSJ2, FSJ4‡, ETS2 Series	241372	Cuts jacketing and outer conductor	209874
LDF4, HL4RP-50, RXL4** Series	207866	Cuts outer conductor and scores jacketing	209874
LDF5, RXL5 Series	222951	Cuts outer conductor and inner conductor and scores jacketing	222954, 209874, for jacket cutting

* Except RXL1-1RNT ** Except RXL4-(1, 2 or 3) RNT † Except FSJ1RN ‡ Except FSJ4RN

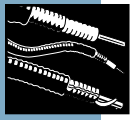

Connector Attachment Tool Kits



The connector interface is one of the most critical factors affecting transmission line operation. Even experienced technicians can make mistakes when equipped with makeshift devices or an inadequate array of simple hand tools, and it only takes a single faulty connection to degrade performance and threaten your operation's revenues.

With the HELIAX® connector attachment tool kit, workmanship is no longer compromised by tools never meant for the job. The kit contains the same specialized tools used by our factory technicians that make connector attachment faster and easier and produces a reliable assembly that matches the quality of the HELIAX cable system serving the operation.

Tool can be ordered individually by type number or in kits. Kit type numbers are listed in the top row and include the tools indicated with an "X".

Type Numbers for Individual Tools	Description	Complete Tool Box	Basic Tool Box	DIN	N	FSJ1/FSJ4/ LDF4 Kit	LDF5 Kit	LDF6 Kit	Air Cable and Waveguide Kit
Kit Type Numbers:		TB-COMP-KIT	TB-BASIC-KIT	TB-DIN-KIT	TB-N-KIT	TB-F14L4-KIT	TB-L5-KIT	TB-L6-KIT	TB-AW-KIT
224351	Tool Box	x	x						
224352	Safety Knife	x	x						
224353	Wire Snips	x	x						
224354	Inch/Millimeter Rule	x	x						
224355	Greasing Brush	x	x						
224356	Point File	x							
224390	Leather Buffing Strap	x				x			
224391	Emery Cloth - 1 ft (30 cm)	x				x			
224392	Flare Hammer	x							x
224393	Flat Hammer	x							x
224394	Beveled Hammer Tip	x							x
222951	LDF5 EASIAX® Cable Tool	x					x		
207866	LDF4 EASIAX® Cable Tool	x				x			
207865	FSJ1/FSJ4 EASIAX® Cable Tool	x				x			
224358	Tapered Drill Punch 3/4"	x							x
224360	Pin Alignment Tool	x							
224361	Cutoff Guide 7/32" (5.5mm) LDF4/FSJ4	x				x			
224362	Cutoff Guide 8/32" (6.3mm)	x							
244494	Cutoff Guide 9/32" (7.1mm)	x							
224363	Cable Flare Tool LDF4	x				x			
224368	Cable Flare Tool LDF5	x					x		
224373	Cable Flare Tool LDF6	x						x	
224377	Soldering Pliers	x				x			
224380	Pin Depth Gauge N-Male	x			x				
224395	Pin Depth Gauge N-Female	x			x				
114468	Pin Depth Gauge DIN Male	x		x					
114469	Pin Depth Gauge Female	x		x					
241953	Chamfer Tool FSJ4	x				x			
243398	Chamfer Tool FSJ2 (not included in tool box)								

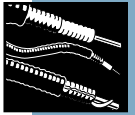

Connector Attachment Torque Wrenches

Andrew torque wrenches attach any type HELIAX® connectors to HELIAX LDF4.5, LDF5, LDF6, LDF7, and LDF12 coaxial cables. All are designed with a mechanism to audibly notify the installer that the proper torque has been reached and release the pressure.

Type Number	Description	Application
244373	2-5/8" torque wrench	LDF12 connectors
244374	2-1/4" torque wrench	LDF7 connectors
244375	1-7/8" torque wrench	LDF6 connectors
244376	21mm torque wrench	LDF4.5 connectors
244377	1-1/4" torque wrench	Coupling torque DIN connectors
244378	1-1/4" torque wrench	LDF5 connectors
244379	13/16" torque wrench	Coupling torque N connectors

Wrench Kit

Kit includes the three wrenches listed below.
Type **244372**

- Type **244459-7**, wrench for LDF7 (1-5/8") connectors
- Type **244459-6**, wrench for LDF6 (1-1/4") connectors
- Type **244459-5**, wrench for LDF5 (7/8") connectors



Crimping Tool for Crimp-On Grounding Kits

Crimping Tool. Used to attach crimp-on lugs for standard and SureGround™ series grounding kits described on pages 610-612. Not required for kits having factory-attached lugsType **207270**

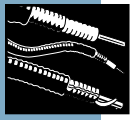

Connector Accessories

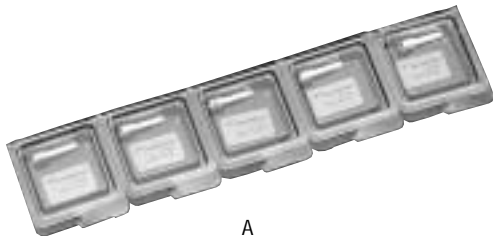

A

A Connector PIN-PAKS. Replacement connector center pins individually packaged in sets (quantities shown below). Each pin can be easily separated from the set. PIN-PAKS for 7/8" cable and smaller include five replacement pins: PIN-PAKS for 1-1/4" and 1-5/8" cable include two replacement pins.

For Connector Type	PIN-PAK Type No.	Quantity Per Kit
F1PNM-H	242881	5
C41SW	241051-3	5
F2NM, F2NM-H	242075-3	5
F2PNM, F2PNM-H	242075-4	5
F2PDM	114402-2	5
F4NM, F4NM-H	241455-3	5
F4NMV2	243640-2	5
F4PNM, F4PNM-H	241455-4	5
F4PNMV2	243472-2	5
F4NF	241496-3	5
F4PNF	241496-4	5
F4PDM	114417-2	5
F4PDMV2	243465-2	5
L2NM, L2NM-H	48335-3	5
L2PNM, L2PNM-H	48335-4	5
L4NM, L4NM-H	241730-3	5
L4PNM, L4PNM-H	241730-4	5
L4PDM	222483-2	5
L4NF	242855	5
L4PNF	242855-2	5
L5NM	43158-5	5
L5PNM, L5PNM-H	241495	5
L5NF	43157-2	5
L5PNF	241092	5
L5PDM	114105	5
L5PDF, L5PDF-BH	114105-2	5
L6PNM, L6PNM-H	243370	2
L6PNF	241057	2
L6PDF, L6PDF-BH	114105-4	2
L6PDM	114105-3	2
L7PNF	241056	2
L7PNM	243371	2
L7PDM	242960	1
V5PNF	244985-2	5
V5PNM	244983-2	5
V5PDF	244989-2	5
V5PDM	244987-3	5

Contact Andrew for other replacement pins.

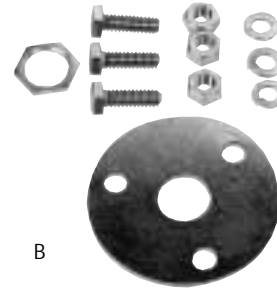

B

B Bulkhead Adapter. For use with type N or UHF jacks for 1/4", 3/8", 1/2" or 7/8" HELIAX® cable. Includes faceplate and mounting hardware.....Type **26016-2**

Connector Reattachment Kit includes rubber O-ring and gasket parts to replace those which may be damaged during disassembly and subsequent reattachment of connectors. Does not include interface O-rings or gaskets.

Cable Types	For Connector Types	Reattachment Kit Type No.
Foam-Dielectric Cables		
LDF2-50	L2 and L42 Series	34767A-38
LDF4-50A	L44 Series, except L4NM, L44PCW, L44PCN, L4NM, L44PCW, L44PCN	34767A-27
FSJ4-50B	F4 and 44AS Series	34767A-51
	F4V2 Series	34767A-39
LDF5-50A	L5 and L45 Series	34767A-66
LDF6-50	L6 and L46 Series	34767A-28
LDF7-50A	L7 and L47 Series	34767A-43
		34767A-35
Air-Dielectric Cables		
HJ4-50, HT4-50	H4PNM, H4PNF, 74PN, 74PW	34767A-22
HJ5-50	H5PNF, H5PNM, 75PN, 75AR, 75PW	34767A-3
	75AG, 75AU	34767A-5
	75ART, 75AGT	34767A-44
	H5NF-T, 75NT	34767A-18
HJ7-50A	87G, 87R	34767A-6
	H7PNF, 87PN, 87S, 87SG	34767A-7
	87SGT, 87ST	34767A-20
	H7NF-T, H7NM-T, 87NT, 87WT	34767A-19
	87Z	34767A-13
HJ12-50	H12PNF, 82PN	34767A-46
	82GF	34767A-50
	82RF	34767A-49
	82R	34767A-47
HJ8-50B	H8(-)-302	34767A-60
	78AGF, 78ARM, 78ARF, 78AGM, 78AS	34767A-10
	78BZ	34767A-30
HJ11-50	H11(-)-602	34767A-57
	H11(-)-M408	34767A-58
	H11(-)-302	34767A-59
	81RF	34767A-15
	81GF	34767A-16
	42826	34767A-40
	42896	34767A-41
	81Z	34767A-17
HJ9-50,	H9(-)-602, H9HP(-)-602	34767A-55
HJ9HP-50	H9(-)-M408, H9HP(-)-M408	34767A-56
	79AG, 79AR	34767A-45
	79AZ, H9HPZ	34767A-31

Connector Adapters



HELIAX® Coaxial Cables

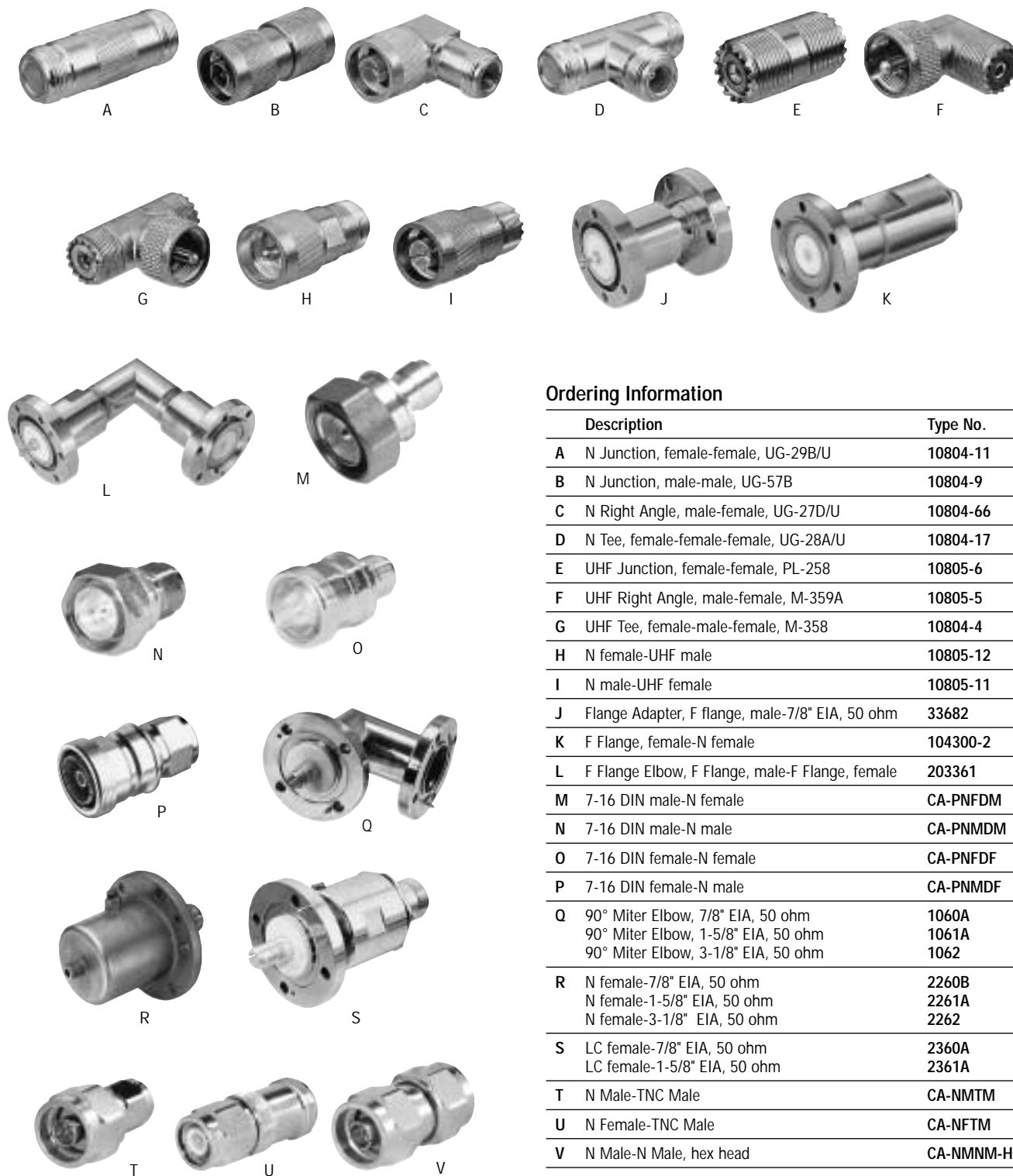

Ordering Information

Description	Type No.
A N Junction, female-female, UG-29B/U	10804-11
B N Junction, male-male, UG-57B	10804-9
C N Right Angle, male-female, UG-27D/U	10804-66
D N Tee, female-female-female, UG-28A/U	10804-17
E UHF Junction, female-female, PL-258	10805-6
F UHF Right Angle, male-female, M-359A	10805-5
G UHF Tee, female-male-female, M-358	10804-4
H N female-UHF male	10805-12
I N male-UHF female	10805-11
J Flange Adapter, F flange, male-7/8" EIA, 50 ohm	33682
K F Flange, female-N female	104300-2
L F Flange Elbow, F Flange, male-F Flange, female	203361
M 7-16 DIN male-N female	CA-PNFDM
N 7-16 DIN male-N male	CA-PNMDM
O 7-16 DIN female-N female	CA-PNFDF
P 7-16 DIN female-N male	CA-PNMDF
Q 90° Miter Elbow, 7/8" EIA, 50 ohm 90° Miter Elbow, 1-5/8" EIA, 50 ohm 90° Miter Elbow, 3-1/8" EIA, 50 ohm	1060A 1061A 1062
R N female-7/8" EIA, 50 ohm N female-1-5/8" EIA, 50 ohm N female-3-1/8" EIA, 50 ohm	2260B 2261A 2262
S LC female-7/8" EIA, 50 ohm LC female-1-5/8" EIA, 50 ohm	2360A 2361A
T N Male-TNC Male	CA-NMTM
U N Female-TNC Male	CA-NFTM
V N Male-N Male, hex head	CA-NMNM-H

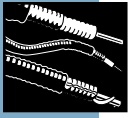

Fire Retardant Cables and Waveguides

Fire Retardance Requirements

Cable and waveguide installed inside a building usually must meet fire retardance requirements. In the United States, the National Electrical Code (NEC)¹ sets the standard for coaxial cable used within buildings and normally has the force of law, as most local electrical codes in the U.S. are based on it. In addition, most building codes cover cable, and other local requirements may exist such as the Fire Gas Toxicity Standards of New York State.

Somewhat similar requirements are provided by the Canadian Electrical Code (CEC), issued by the Canadian Standards Association (CSA). Other countries' requirements often reference the International Electrotechnical Commission (IEC) standards.

Definitions

Some terms used in building construction are referred to in fire-retardant cable regulations. They are defined below:

Conduit. A tube or duct for enclosing electrical wires and cable. Conduit may be metallic or nonmetallic.

Duct. A closed channel, tube, or pipe used to transport air, dust, vapors, etc.

Plenum. A compartment or chamber to which one or more air ducts are connected and forms part of the air distribution system of a building.

Raceway. An enclosed channel designed expressly for holding wires, cables, or bus bars, with additional functions as permitted in the National Electrical Code. Raceway may be metallic or nonmetallic.

Riser. A vertical shaft passing from floor to floor. Risers may or may not be fireproof or have firestops at each floor.

Coaxial Cable Applications Defined by the NEC

In the National Electrical Code, coaxial cable falls under the Community Antenna Television Systems (CATV) category. The NEC provides requirements for coaxial cable installed within buildings in Article 820. These requirements cover all installations except where the cable enters the building from the outside, does not pass through a plenum or riser, and is (a) of any length, but runs throughout in a properly grounded metal conduit (rigid or intermediate) or (b) no longer than 50 feet (15.2 m), within the building, and terminated at a

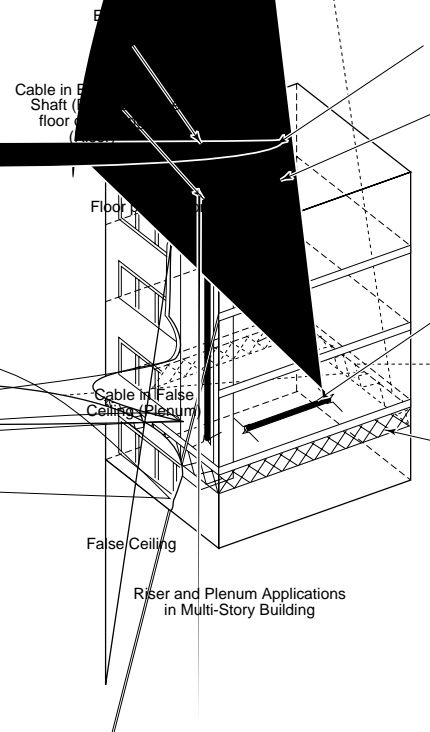
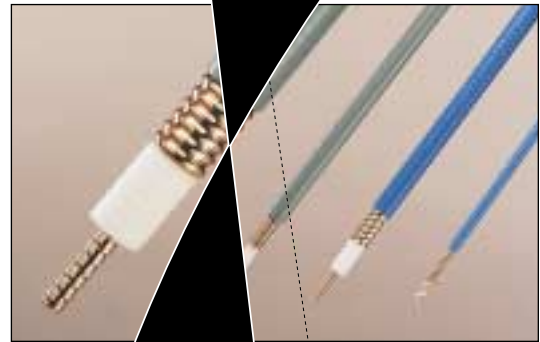

grounding block. The requirements state that these cables shall be listed as being resistant to the spread of fire as specified in the code, listed as being suitable for the purpose, and properly marked.

Four categories of listed coaxial cable are defined (in descending order of fire-resistance rating): Type CATVP, plenum cable; Type CATVR, riser cable; Type CATV, general purpose coaxial cable; and Type CATVX, limited use coaxial cable.

¹and NEC are registered trademarks of the National Fire Protection Association.

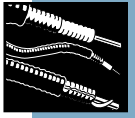

Fire Retardant Cables and Waveguides

HELIAX® Coaxial Cables

Wiring In Ducts, Plenums and Other Air-Handling Spaces

Only Type CATVP listed cables, which have extremely high fire resistance coupled with low smoke emission, are permitted by the NEC to be installed in ducts, plenums or other spaces used for environmental air (such as above a false ceiling) without additional protection. All other cables, which must be listed as Type CATVX or higher, must be contained within rigid metal conduit, flexible metallic tubing or similar barrier, depending on the application. (These conditions preclude use of RADIAX® cables, so these cables must be CATVP listed to be installed in a plenum or duct).

Wiring In Vertical Runs

Type CATVR listed cables are required for installation in risers or any other floor penetration connecting more than one floor. Type CATVP cables, which have even higher fire resistance, can be substituted for Type CATVR cables. CATV or CATVX listed cables can also be installed in risers provided that they are encased in noncombustible tubing (not applicable to RADIAX cables) or are located in a fireproof shaft having firestops at each floor.

General Purpose Wiring Within Buildings

All coaxial cables to be installed within buildings in locations other than plenums and risers, as defined above, must be at least Type CATV listed for fire resistance unless one of the following exceptions applies:

- Type CATVX cable enclosed in raceway.
- Type CATVX cable in nonconcealed spaces where the exposed length does not exceed 10 ft (3.05 m).
- Small diameter Type CATVX cables installed in dwellings.

Type CATVR and Type CATVP cables, which have passed more stringent tests, are permitted to be substituted for Type CATV cables.

Acceptable cables are summarized on the chart on page 629.

Model Building Code Requirements for Coaxial Cable

Some model building and mechanical codes also include fire retardance requirements for coaxial cable. Generally, they stipulate that exposed cables in concealed spaces over suspended ceilings, and other spaces used for environmental air handling purposes as defined in the particular code, be listed and labeled as plenum cable per NEC requirements.

Fire Gas Toxicity

Fire Retardant Jacketing Characteristics. Some coaxial cables use halogenated polymeric jacketing to provide fire retardance. (Halogens are chemically related elements such as fluorine, chlorine, and bromine.) The drawback to such materials is increased levels of smoke and toxic gases under fire.

All HELIAX® Coaxial Cables rated Type CATVR achieve fire retardance by using non-halogenated jacketing. While such a jacketing has low toxicity characteristics when burned, it is somewhat less effective at high temperatures than halogenated jacketing. Presently, it is not possible to achieve the highest fire retardance rating, CATVP, without either employing halogenated jacketing or omitting the jacket entirely; consequently, Type CATVP listed HELIAX cables presently use halogenated fire retardant jacketing.

New York State Requirements. The New York State Department of State (DOS) Office of Fire Prevention and Control publishes a Fire Gas Toxicity Data File for products covered by Article 15, Part 1120 of the New York State Uniform Fire Prevention and Building Code. Only products listed in this directory are permitted to be used in the construction of some buildings in New York State.

All of Andrew Corporation's cable and waveguide products are listed in the Fire Gas Toxicity Data File, as follows:

New York State DOS File Number	Listed Manufacturer	Market Name	Listed Cables
16120-880602-2007	Andrew	RADIAX Slotted Coaxial Cable - Foam Dielectric	All Codes
16120-880602-2008	Andrew	HELIAX Coaxial Cable - Foam Dielectric	All Codes
16120-871217-1058	Andrew	HELIAX Coaxial Cable - Air Dielectric	All Codes
16120-880602-2006	Andrew	HELIAX Elliptical Waveguides	All Codes

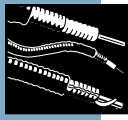

Fire Retardant Cables and Waveguides

Caution: Since local requirements may vary, check with your local building inspector to make certain that a proposed installation conforms with all applicable electrical codes, building codes, mechanical codes and fire protection codes.

Andrew Fire Retardant Cables - Indoors or Outdoors

Andrew offers a full line of fire retardant products for HELIAX® coaxial cable, RADIAX® radiating coaxial cable and HELIAX elliptical waveguide. A listing of these products appears on page 629.

Fire retardant cables are suitable for indoor/outdoor use. Outdoor service life is 10 years, minimum, for HELIAX cables with CATVR (RN) rated jacketing. CATVP (RP) rated cables have an even longer outdoor service life. Refer to the table on page 629 for HELIAX and RADIAX fire retardant cable temperature ratings.

Acceptable Cables and Waveguides by Application - United States

Application Within Building	Type CATVP	Type CATVR	Type CATV	Type CATVX	Unlisted	NEC 1999 Section
Ducts, Plenums and Other Environmental Air Spaces, Exposed	√					820-53(a)
Ducts, Plenums and Other Environmental Air Spaces, in Metal Tubing or Conduit	√	√	√	√		820-53(a), Exception
Vertical Runs penetrating more than 1 floor, or in a shaft, exposed	√	√				820-53(b), (Non-residential)
Vertical Runs penetrating more than 1 floor, or in a shaft, encased in Metal Raceway or in a Fireproof Shaft having Firestops at each floor	√	√	√	√		820-53 (b), Exception No. 1
All other locations except those given above, exposed for more than 10 ft (3.05m)	√	√	√			820-53 (c), (Non-residential)
All other locations except those given above, exposed for 10 ft (3.05m) or less, nonconcealed	√	√	√	√		820-53 (c), Exception No. 2
All other locations except those given above, enclosed in Raceway	√	√	√	√		820-53 (c), Exception No. 1
All other locations except those given above, cable enters from outside, in Grounded Metal Conduit	√	√	√	√	√	820-50, Exception No. 2
All other locations except those given above, cable enters from outside, less than 50 ft (15.2m) within building, grounded.	√	√	√	√	√	820-50, Exception No. 3

Andrew Fire Retardant Coaxial Cables and Elliptical Waveguides

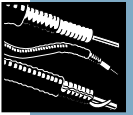

Product	Type CATVP (UL 910)		Type CATVR (UL1666)		Type CATV (UL 1581, Flame Test 1160)		Type CATVX	
	Type No.	Refer to Page	Type No.	Refer to Page	Type No.	Refer to Page	Type No.	Refer to Page
RADIAX® Cable								
1/4"	-	-	RXL1-1RNT	663	-	-	-	-
3/8"	-	-	RXL2-2RNT	663	-	-	-	-
1/2" - 3	-	-	RXL4-3RNT	664	-	-	-	-
1/2" - 2	RXP4-2	665	RXL4-2RNT	663	-	-	-	-
1/2" - 1	RXP4-1	665	RXL4-1RNT	663	-	-	-	-
7/8"	-	-	RXL5-1RNT	664	RXL5-1RNT1	664	-	-
1-1/4"	-	-	RXL6-1RNT	664	RXL6-1RNT1	664	-	-
1-5/8"	-	-	RXL7-1RNT	664	RXL7-1RNT1	664	-	-
HELIAX® Cable								
Superflexible								
1/4", 50Ω	ETS1-50T	477	FSJ1RN-50B	474	FSJ1RN-50B	474	FSJ1RN-50B	474
1/4", 75Ω	-	-	FSJ1RN-75A	574	FSJ1RN-75A	574	FSJ1RN-75A	574
3/8", 50Ω	ETS2-50T	483	FSJ2RN-50	480	FSJ2RN-50	480	FSJ2RN-50	480
1/2", 50Ω	-	-	FSJ4RN-50B	485	FSJ4RN-50B	485	FSJ4RN-50B	485
1/2", 75Ω	-	-	FSJ4RN-75A	576	FSJ4RN-75A	576	FSJ4RN-75A	576
Extraflexible								
3/8", 50Ω	-	-	EFX2RN-50	489	EFX2RN-50	489	EFX2RN-50	489
Foam Dielectric								
1/4", 50Ω	-	-	LDF1RN-50	491	LDF1RN-50	491	LDF1RN-50	491
3/8", 50Ω	-	-	LDF2RN-50	493	LDF2RN-50	493	LDF2RN-50	493
1/2", 50Ω	-	-	LDF4RN-50A	496	LDF4RN-50A	496	LDF4RN-50A	496
1/2", 75Ω	-	-	LDF4RN-75A	578	LDF4RN-75A	578	LDF4RN-75A	578
5/8", 50Ω	-	-	LDF4.5RN-50	500	LDF4.5RN-50	500	LDF4.5RN-50	500
7/8", 50Ω	-	-	LDF5RN-50A	506	LDF5RN-50A	506	LDF5RN-50A	506
7/8", 50Ω	-	-	VXL5RN-50	503	VXL5RN-50	503	VXL5RN-50	503
1-1/4", 50Ω	-	-	LDF6RN-50	513	LDF6RN-50	513	LDF6RN-50	513
1-1/4", 50Ω	-	-	VXL6RN-50	510	VXL6RN-50	510	VXL6RN-50	510
1-5/8", 50Ω	-	-	LDF7RN-50A	520	LDF7RN-50A	520	LDF7RN-50A	520
1-5/8", 50Ω	-	-	VXL7RN-50	517	VXL7RN-50	517	VXL7RN-50	517
2-1/4", 50Ω	-	-	LDF12RN-50	524	LDF12RN-50	524	LDF12RN-50	524
Air Dielectric								
1/4", 50Ω	HS1RP-50A	527	-	-	-	-	-	-
1/4", 50Ω	HST1-50	529	-	-	-	-	-	-
3/8", 50Ω	HS2RP-50	531	-	-	-	-	-	-
3/8", 50Ω	HST2-50	533	-	-	-	-	-	-
1/2", 50Ω	HS4RP-50	546	-	-	-	-	-	-
1/2", 50Ω	HL4RP-50	540	HJ4RN-50	535	-	-	-	-
1/2", 50Ω	HST4-50	549	-	-	-	-	-	-
1/2", 50Ω	HLT4-50T	543	-	-	-	-	-	-
5/8", 50Ω	-	-	HJ4.5RN-50	552	-	-	-	-
7/8", 50Ω	HJ5RP-50	555	HJ5RN-50	555	-	-	-	-
7/8", 75Ω	-	-	HJ5RN-75	582	-	-	-	-
1-5/8", 50Ω	HJ7RP-50A	560	HJ7RN-50A	560	-	-	-	-
2-1/4", 50Ω	-	-	HJ12RN-50	563	-	-	-	-
HELIAX Elliptical Waveguide***								
Type EWP52	-	-	35409-20	172	-	-	-	-
Type EWP63	-	-	35409-18	174	-	-	-	-
Type EW63	-	-	35409-19	174	-	-	-	-
Type EWP77	-	-	35409-22	178	-	-	-	-
Type EW85	-	-	35409-17	180	-	-	-	-
Type EWP90	-	-	35409-16	182	-	-	-	-
Type EW127A	-	-	35409-15	184	-	-	-	-
Type EW132	-	-	35409-14	186	-	-	-	-
Type EWP180	-	-	35409-21	188	-	-	-	-

** High temperature foam dielectric. *** Type CATVP elliptical waveguides are available on request.

All cables meet standards BS4066 Part 1 and IEC332 Part 1. Type CATVP, CATVR and CATV cables meet BS4066 Part 3 and IEC332 Part 3, Category C.

All type CATVP air-dielectric cables are also listed by the Canadian Standards Association (CSA) as Communications Cable, Type CXC-FT4, FT6. They carry dual UL/CSA markings.

All type CATVR, CATV, and CATVX RADIAX, superflexible, and foam-dielectric cables listed comply with equivalent Canadian Standards Association (CSA) requirements and are CSA marked.

Temperature Ratings for HELIAX® Fire Retardant Coaxial Cables

	Recommended Temperature Range °C (°F)		
	Installation	Storage	Operation
Types CATVR, CATVX, and CATV Jacketed Cable, Foam and Air	-25 to 60 (-13 to 140)	-30 to 80 (-22 to 176)	-30 to 80 (-22 to 176)
Type CATVP Jacketed Cable, Foam and Air			
Polyethylene Dielectric	-40 to 60 (-40 to 140)	-40 to 85 (-40 to 185)	-40 to 85 (-40 to 185)
PTFE Dielectric	-40 to 60 (-40 to 140)	-40 to 150 (-40 to 302)	-40 to 150 (-40 to 302)

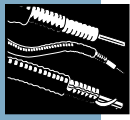

Intermodulation Generation

Figure 1 — Bulk Length of LDF4-50A

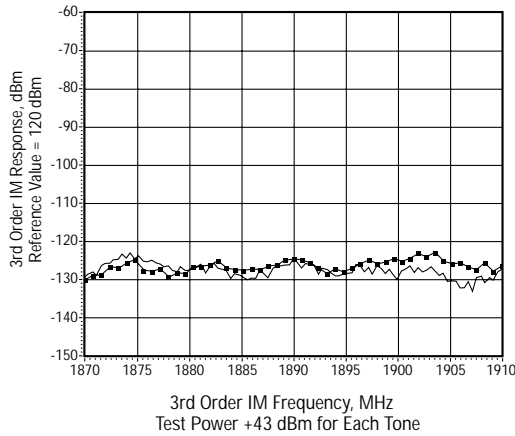
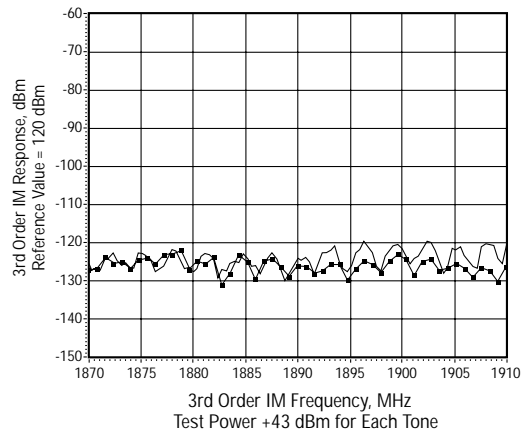

Figure 2 — 15 ft Assembly of FSJ4-50B



Intermodulation (IM), the intermixing of fundamental signal frequencies in a nonlinear circuit, has been a problem in multichannel communication systems for years. IM produces additional spurious signals at frequencies close to the operating frequencies, which can create additional noise in the system or even swamp the channel and make it unavailable for traffic. The many channels in modern wireless communications systems are typically arranged into base station transmit and receive frequency bands. Depending on the particular generating signal frequencies, IM products can fall into these receive frequencies. It therefore becomes desirable to keep the IM level low enough to prevent additional noise at the receivers.

Any deviation from linearity in a circuit will cause some IM. Nonlinearity is present when the voltage is not exactly proportional to the current or if output power is not exactly proportional to input power. Imperfect contacts at conductor junctions and the presence of ferromagnetic materials in or near the current path are the two main causes of nonlinearity in passive circuits. Measured passive IM levels are not very dependent on frequency, but do depend on the signal amplitude. Thus, when measuring or specifying IM performance of a component, the power levels of the carriers must be specified. Typically, testing is performed using two tones fairly closely spaced in frequency, the power level of each being 20 W (+43 dBm).

Low IM vs. Inferior Designs

	dBm
Large number of components	-95
Low pressure contact, outer	-96
Low pressure contact, inner	-85
Nickel plating	-83
Low IM design	-120 to -130

HELIAx cables, constructed from a single inner and single outer conductor deliver the best IM performance. Because current flow in coaxial cables is longitudinal, designs with many individual conductors require the current to cross numerous boundaries, each boundary being capable of producing IM products. It is not possible to apply high pressure between the individual conductors of a braided or foil-braid cable, for example, to improve IM performance. IM levels for braided cables are typically -80dBm or worse at a test power level of +43 dBm.

By contrast, Figure 1 and Figure 2 show the excellent IM performance of HELIAx cables. Figure 1 is the IM characteristic for a bulk length (approximately 5,000 feet) of LDF4-50A, swept in frequency through the PCS band, and Figure 2 is a similar plot for an assembly length (15 feet) of FSJ4-50B. Levels for both are -120 dBm or better at the test power level of +43 dBm for each tone.

HELIAx connectors are also designed and manufactured for the lowest IM. Three factors are important in connector design to minimize IM generation. First, the number of individual contact surfaces must be a few as possible. Second, where contact surfaces are necessary, they must be designed for excellent contact by using means to generate high pressure or by using soldering. Third, base materials, platings, and underplatings at RF current-carrying surfaces must not be made of ferromagnetic materials. The table shows measured IM levels for various RF connectors fitted to short lengths of cable. Andrew connectors, designed and constructed using these principles for low IM generation outperform other manufacturers' designs that deviate from these principles in one way or another.

Coaxial Transmission Line Technical Data

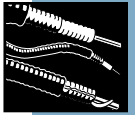

HELIAX® Coaxial Cables

Figure 1 – Variation of Attenuation with Ambient Temperature

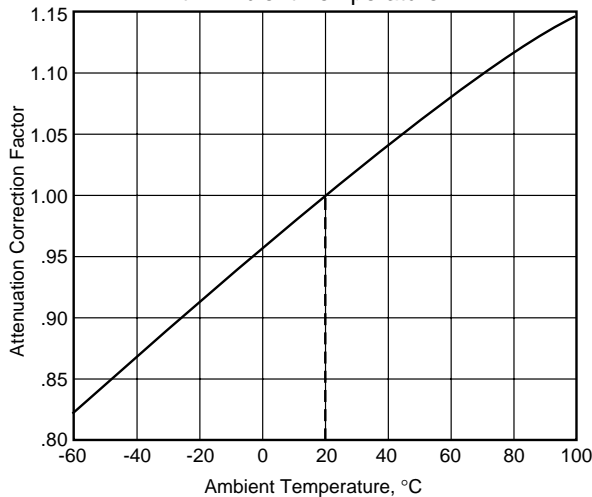
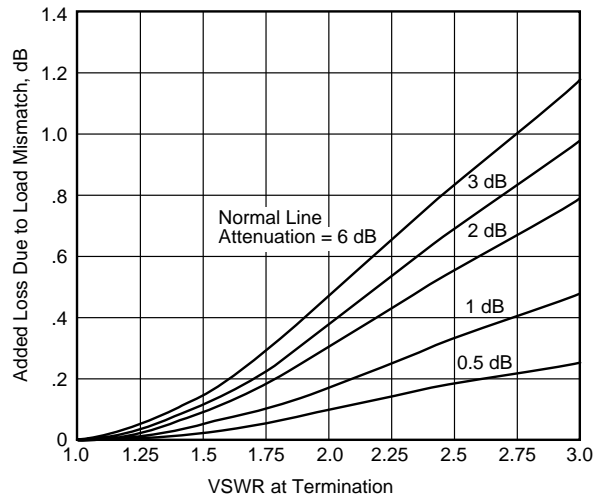

Figure 2 – Effect of Load VSWR on Transmission Loss



Attenuation

The attenuation versus frequency characteristics of HELIAX coaxial cables are provided as part of the data for each cable in this catalog. The figures are guaranteed to within $\pm 5\%$. The values provided are for 20°C (68°F) ambient and increase slightly with higher temperature or applied power, up to approximately 15% above the curves at 100°C (212°F) ambient temperature. Figure 1 shows this relationship.

Effect of Connector on Transmission Line Loss

Usually, connector insertion loss is negligible compared with the attenuation of the cable. Connector insertion loss depends on the frequency of operation. You can easily calculate the total transmission line insertion loss (the sum of cable attenuation and insertion loss of the connectors) using our AASP software available on our web site at www.andrew.com. To approximate insertion loss for two connectors, add 0.1 dB to the transmission line loss.

Temperature Ratings for HELIAX® Coaxial Cables

		Storage	Installation	Operation
Standard Black Polyethylene Jacketed Cables				
Up to 2-1/4" Cables	°C	-70 to 85*	-40 to 60	-55 to 85
	°F	-94 to 185*	-40 to 140	-67 to 185
3" and Larger Cables	°C	-70 to 85*	-40 to 60	-40 to 85
	°F	-94 to 185*	-40 to 140	-40 to 185
Connectors				
	°C	-70 to 100**	-40 to 60	-55 to 150***
	°F	-94 to 212**	-40 to 140	-67 to 302***
CATVX Rated Cables				
	°C	-30 to 80	-25 to 60	-30 to 80
	°F	-22 to 176	-13 to 140	-22 to 176
CATVR Rated Cables				
	°C	-30 to 80	-25 to 60	-30 to 80
	°F	-22 to 176	-13 to 140	-22 to 176
CATVP Rated Cables				
Polyethylene Dielectric	°C	-40 to 85	-40 to 60 [†]	-40 to 85
	°F	-40 to 185	-40 to 140 [†]	-40 to 185
High Temperature Dielectric	°C	-40 to 100	-40 to 60 [†]	-40 to 150
	°F	-40 to 212	-40 to 140 [†]	-40 to 302

* Cable with connectors attached rated to -40°C (-40°F).

** Upper temperature limited by connector package material. Storage defined as packaged connectors, not connectors installed on cable.

*** If connectors are operated above 100°C (212°F) and then separated, interface seals (gaskets or O-rings) should be replaced before remating. Air cable and connectors will operate below -40°C (-40°F), but may experience air pressure loss exceeding 1lb/in² (7kPa) in 24 hours.

† For CATVP air cables, 7/8" and larger, the installation temperature is -20° to 60°C (-4° to 140°F)

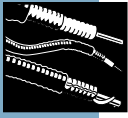

Coaxial Transmission Line Technical Data

Load VSWR Effect on Total Transmission Loss

When the transmission line is attached to a load, such as an antenna, the VSWR of the load increases the total transmission loss of the system. This effect is quite small for normal conditions. Figure 2 on page 631, shows the minimum increase in loss with load VSWR, assuming a VSWR of 1.0 at the input of the transmission line. This requires use of an input matching device.

Power Rating Considerations

Both peak- and average-power ratings are required to fully describe the capabilities of a given transmission line. Typically, peak-power ratings limit usage with amplitude modulation at medium frequencies (530-1610 kHz) or pulsed usage, while average-power ratings limit the high frequency usage.

Peak-Power Rating

The peak-power rating of a transmission line is limited by voltage breakdown between the inner and outer conductors.

Voltage breakdown is essentially independent of RF frequency, but varies with line pressure and type of pressurizing gas. Peak-power ratings are, therefore, generally stated for the following standard conditions: VSWR = 1.0, zero modulation and one atmosphere absolute dry air pressure (0 lb/in² or 0 kPa gauge) at sea level.

The peak-power rating of the selected cable must be derated for modulation technique and VSWR, as follows:

Peak Power Derating for Modulation and VSWR

Modulation	Peak Power Derating Calculation
AM	$P_{MAX} = \frac{P_{PK}}{(1+M)^2 \text{ VSWR}}$
FM and DTV	$P_{MAX} = \frac{P_{PK}}{\text{VSWR}}$
Analog TV	$P_{MAX} = \frac{P_{PK}}{(1+AU+2\sqrt{AU}) \text{ VSWR}} = \frac{P_{PK}}{(2.09) \text{ VSWR}}$

Where:

- P_{MAX} = Derated peak power
- P_{PK} = Peak power rating of cable
- M = Amplitude modulation index (100% = 1.0)
- VSWR = Voltage standing wave ratio
- AU = Aural to visual ratio (20% Aural: AU = 0.2)
- 2.09 = Modulation derating factor for TV, for AU=0.2

Rated transmitter power must be less than calculated derated peak power of the cable for safe operation. For digital TV (DTV), peak power is typically 7dB higher than average power.

From derating expressions, it can be seen that 100% amplitude modulation increases the peak power in the transmission line by a factor of 4. Also, the peak power in the transmission line increases directly with VSWR.

The transmission line peak-power rating can be significantly increased by pressurization. See page 633 for details.

An adequate safety factor on peak power is necessary to safeguard against voltage breakdown which can result in permanent damage to the transmission line. All HELIAX semiflexible coaxial cables are high-voltage tested to the equivalent of 200% of their rated peak powers (safety factor of 1.4 on voltage), and all rigid coaxial lines to the equivalent of 400% of rated peak powers (safety factor of 2.0 on voltage). These safety factors are intended as a provision for transmitter transients, lightning induced transients, and high voltage excursions due to other unforeseen causes. Andrew is known for its conservative specifications that insure long term, reliable performance. We continue to hold this commitment to our customers by maintaining the highest level of quality and performance.

HELIAX® peak-power ratings are determined according to the relation:

$$P_{PK} = \frac{(E_P \times 0.707 \times 0.7)^2}{Z_C \times SF}$$

Where:

- P_{PK} = Cable power rating, standard conditions
- E_P = dc production test voltage
- 0.707 = RMS factor
- 0.7 = dc to RF factor (empirically verified)
- SF = Safety factor on voltage
 - = 1.4 for HELIAX semiflexible cables
 - = 2.0 for rigid coaxial lines
- Z_C = Characteristic impedance

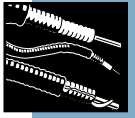

Figure 3 – Pressurization Factors

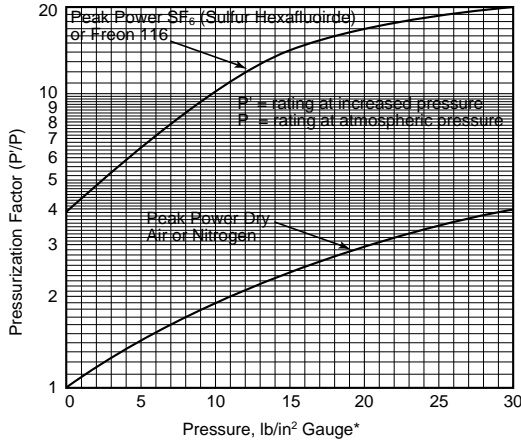
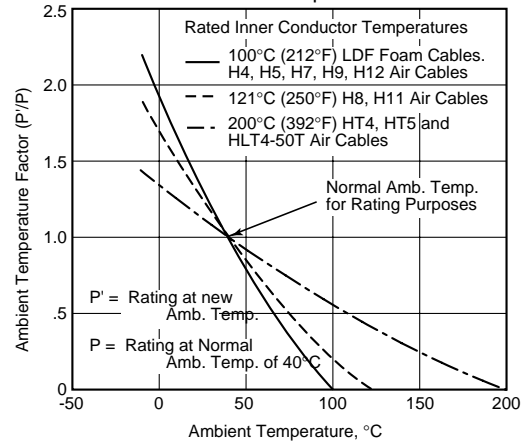

Figure 4 – Variation of Average Power Rating with Ambient Temperature



* For kPa, multiply by 6.895

Typical dc production test voltages for various sizes of semiflexible coaxial cable and rigid line are shown below.

Nominal size	Impedance ohms	Ep, kV	
		Flexible cables	Rigid lines
7/8"	50	6	–
1-1/4"	50	9	–
1-5/8"	50	11	11
2-1/4"	50	13	–
3"	50	16	–
3-1/8"	50	–	19
4"	50	21	–
5"	50	27.5	–
6-1/8"	50, 75	–	36
7-3/16"	75	–	41.8
8-3/16"	75	–	47

Foam-dielectric cables have a greater dielectric strength than air-dielectric cables of similar size. For this reason they might be expected to have higher peak-power ratings than air cables. Higher peak-power ratings usually can not be realized, however, because the commonly used connectors for foam cables have air spaces at the cable/connector interface which limit the allowable RF voltage to "air cable" values. Andrew rates similar size foam- and air-dielectric cables alike for this reason.

Effect of Connector on Power Rating

The peak power handling capability of a cable assembly is the smaller of the values for the cable and the connectors. The following table shows power ratings for common connectors at standard conditions of VSWR = 1.0, zero modulation and one atmosphere dry air pressure (0 lb/in² or 0 kPa gauge) at sea level.

Connector Power Ratings

Connector Type	DC Test Voltage kV	Average Power kW*	Peak Power kW
SMA	1.0	0.1	2.5
BNC	1.5	0.1	5.6
TNC	1.5	0.3	5.6
UHF	2.0	0.3	10
N	2.0	0.6	10
HN	4.0	0.6	40
SC	4.2	1.2	44
7-16 DIN	4.0	1.3	40
4.1/9.5 DIN	2.5	1.2	16
LC	5.0	3.5	63
7/8" EIA	6.0	1.7	90
1-5/8" EIA	11	4.9	300
3-1/8" EIA	19	16	902
4-1/2" IEC	21	27	1100
6-1/8" EIA	27.5	57	1890

* Average power ratings of the connector interfaces are based on an operating frequency of 900 MHz. The values shown in this table are typical for most applications.

Increased Peak Power Ratings

Pressurization and/or the use of high-density gases with high dielectric strength can be used to increase peak-power ratings. These effects are shown in Figure 3.

For a given transmission line pressure, the increase in peak-power rating is significant. For example, a line pressure of 10 lb/in² (70 kPa) dry air increases the peak-power rating by a factor of 1.9. Pressurization above 30 lb/in² (207 kPa) is not recommended.

Average Power Rating

Average power ratings for semiflexible cables are determined by the maximum permissible inner conductor temperature. This maximum temperature depends on the type of dielectric, and is governed by considerations of the long-term life of the dielectric. Average power ratings for rigid coaxial lines are also determined by the maximum inner conductor temperature. For rigid lines this maximum temperature is set primarily by considerations of differential expansion of inner and outer conductors, and the maximum movement permissible at the joints (inner connectors).

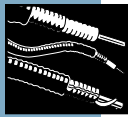
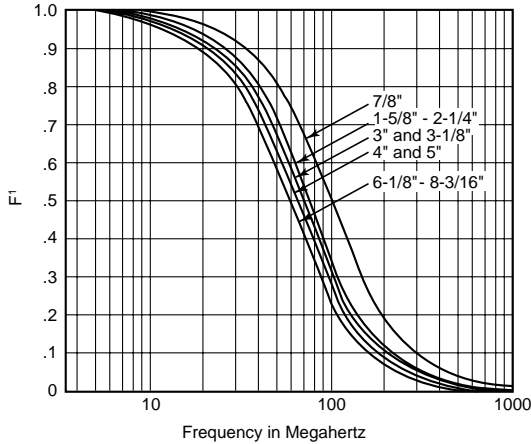

Figure 5 – Derating Factor for Average Power Due to VSWR



Andrew average power ratings are based on a VSWR of 1.0, atmosphere pressure and ambient temperature of 40°C (104°F).

Derating Average Power for Modulation Condition

To convert rated transmitter power to average power for analog television transmission, multiply by 0.8 (totally black picture + aural signal). For FM radio and digital television (DTV), the factor is 1.0. Transmission lines for AM radio at MF frequencies (530-1610 kHz) are usually peak power limited. At higher (HF) frequencies, the limitation is average power capability and the required derating factor, D.F., is:

$$D.F. = 1 + \frac{M^2}{2}$$

where M is the modulation depth (100% = 1.0), expressed decimally.

Average Power Rating Adjustment for Ambient Temperature

The baseline power rating can be adjusted to meet the actual usage conditions. Figure 4 shows the variation of average power rating with ambient temperature.

Derating Average Power for VSWR

The derating factor (D.F) is calculated from the following formula:

$$D.F. = \frac{2 (VSWR)}{VSWR^2 (1 + F^1) + 1 - F^1}$$

where F¹ is a factor that varies with frequency and line size. This calculation of derating factor is conservative in that it assumes all reflected power is re-reflected at the transmitter and absorption of the reflected signal by the line attenuation is small. Select the factor from the applicable curve in Figure 5, calculate factor D.F., and multiply by the average power from the cable characteristics table.

Figure 6 – Variation of Average Power Rating with Intensity of Direct Solar Radiation

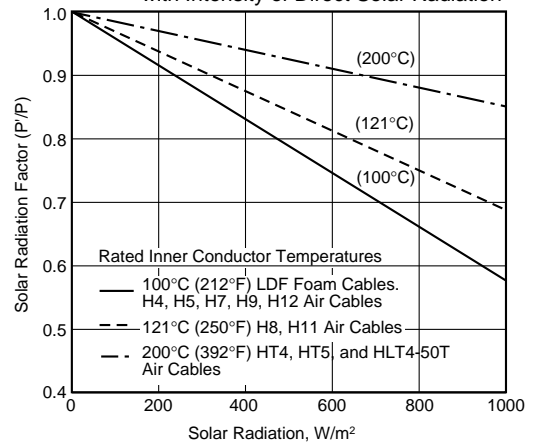

For example: Calculate power rating for 3" HJ8-50B cable operating at 100 MHz with VSWR = 1.1, F¹ (from Figure 5) = 0.33:

$$D.F. = \frac{2 \times 1.1}{1.1^2 \times (1 + 0.33) + 1 - 0.33} = 0.965$$

Average Power Rating at 1.00 VSWR = 42.4 kW (from page 566)

Average Power Rating at 1.1 VSWR = 42.4 x 0.965 = 41.0 kW

Derating Average Power for Direct Solar Radiation

The average power handling capability of a cable exposed to direct solar radiation will be reduced. The appropriate derating factors for the different cable types are shown in Figure 6.

The average radiation intensity for moderate climates is 200 W/m² or less. Hot, dry climates give solar radiation intensities which at the hottest time of the day can be 1,000 W/m² or higher. The mean value over the day, which is applicable to average power derating calculations provided absolute maximum temperatures are not exceeded, is up to 400 W/m². These hot, dry locations are also subject to elevated ambient temperatures, which must also be considered (Figure 4).

Figure 7 — Average Daily Direct Normal Solar Radiation (MJ/m²), Annual

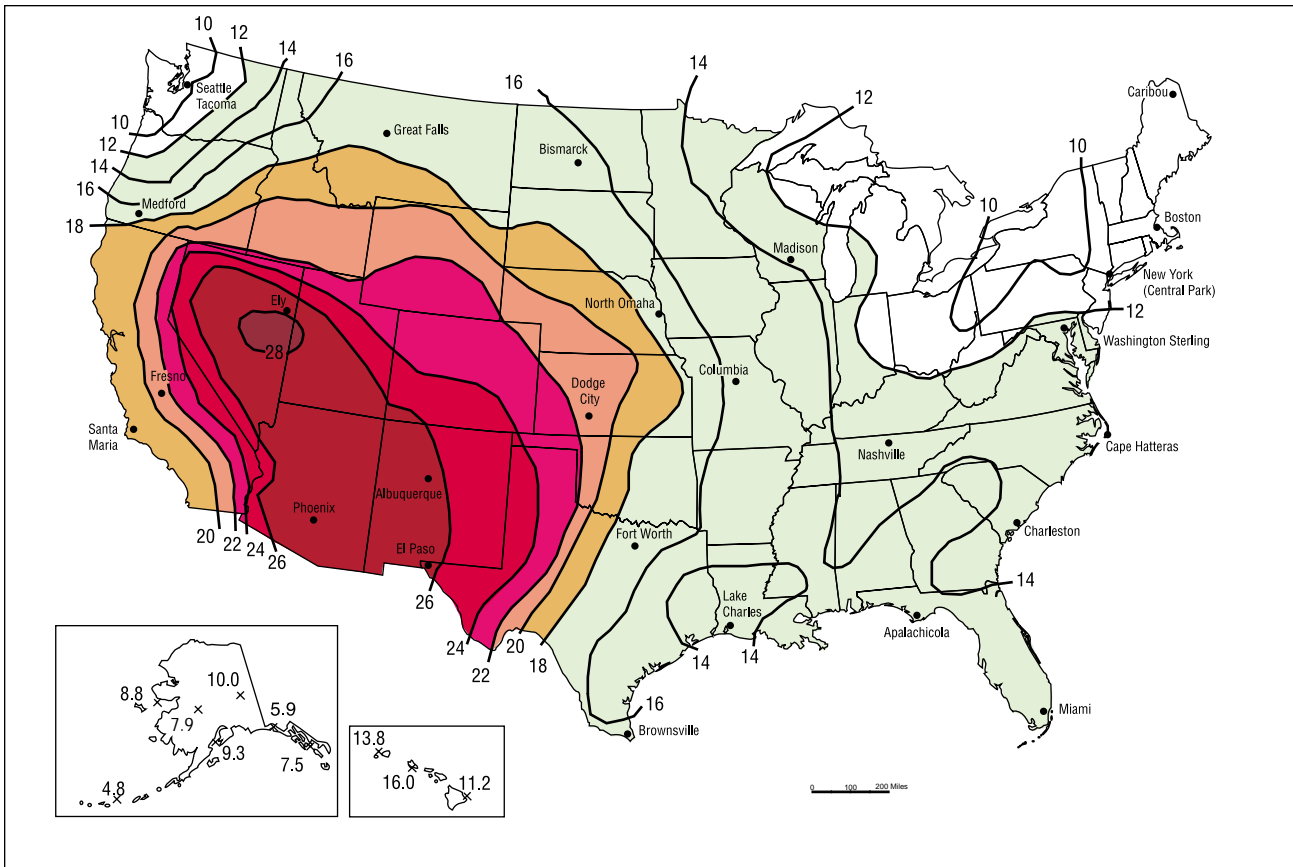

Values for average direct solar radiation for locations in the USA are shown in Figure 7. For conversion purposes, to determine a derating factor from Figure 6 from the information by location from Figure 7, 1 MJ/m² over a 24-hour period is equivalent to 11.6 W/m².

Derating Average and Peak Powers for Altitude

Derating factors for average and peak powers with altitude are shown in the following table. These factors have been determined assuming just nominal overpressure inside the transmission line. Both average and peak powers must be derated because the lower atmospheric pressure with increasing altitude reduces both heat transfer from inner and outer conductors, and the dielectric strength of the air inside the line.

Derating Average and Peak Powers for Altitude

Altitude above Sea Level ft (m)	P1/P Average Power	P1/P Peak Power
0 (0)	1.00	1.00
5000 (1524)	0.92	0.69
8000 (2438)	0.87	0.53
10500 (3200)	0.84	0.44
15000 (4572)	0.78	0.30

Efficiency

The efficiency of a transmission line depends on its length and attenuation. The efficiency is defined as the percent of transmitter power which reaches the antenna. It can be calculated as:

$$\text{Efficiency} = \frac{100\%}{10^{\left(\frac{\text{dB}}{10}\right)}}$$

where dB is the total attenuation of the transmission line at the frequency of interest.

The remaining power is lost in the transmission line and is dissipated as heat.

