



*Earth Station Antenna  
Products and Systems*



## Index

---

<b>Earth Station Antenna Services Introduction</b> . . . . .	392
--	-----

---

<b>Earth Station Antenna Products</b> . . . . .	394
Earth Station Antenna Performance Quick-Reference Guide . . . . .	394

---

<b>Fixed ESAs</b>	
1.2- thru 3.6-Meter ValuStar™ Antennas . . . . .	396
3.7-Meter Earth Station Antennas. . . . .	398
3.9-Meter Earth Station Antennas. . . . .	400
4.5-Meter Earth Station Antennas. . . . .	402
4.9-Meter Earth Station Antennas. . . . .	404
5.6-Meter Earth Station Antennas. . . . .	406
6.5-Meter Earth Station Antennas. . . . .	408
7.3-Meter Earth Station Antennas. . . . .	410
7.6-Meter Earth Station Antennas. . . . .	412
9.3-Meter Earth Station Antennas. . . . .	414
ESA Options . . . . .	416

---

<b>Earth Station Antenna Customer Definition Check List</b> . . . . .	417
---	-----

---

<b>Transportable ESAs</b>	
1.2-/1.5-/1.8-/2.4-Meter NewsFlash™ Transportable SNG Antennas. . . . .	418
3.7- and 4.5-Meter Trifold™ Transportable Earth Station Antennas . . . . .	420

---

<b>Packaged System Products</b>	
VALULink™ II . . . . .	422

---

<b>Systems Approach and Turnkey Capabilities</b> . . . . .	425
--	-----

---

<b>Communication Satellite Network Solutions.</b> . . . . .	426
---	-----

---

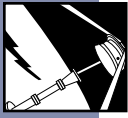

## Complete Satellite Communication Systems and Service

### *Applications*

Andrew has been known as a world leader in communications equipment for over half a century. The Andrew Earth Station Antenna products have become a standard by which all other ESAs are evaluated. Andrew ESAs are available in a wide range of sizes for diverse applications such as:

- *Corporate Networks*
- *Independent Broadcast*
- *Broadcast Network Distribution*
- *Satellite Carrier Services*
- *State and Local Governments*
- *International Communications*
- *Distance Learning*

### *Variety*

Andrew offers a wide variety of standard communication systems.

- *C-, UC, X-, Ku-, Ka-Band Systems*
- *R/T Antennas from 2.4- to 9.3-Meters and R/O Antennas from 1.2- to 9.3- Meters*
- *Simultaneous C-/Ku-Band Receive Systems*
- *Transportable Antenna Systems*
- *Digital and Analog Receive/Transmit Systems*
- *Satellite Networks*

Andrew continues to develop and design new products for our customer's opportunities. Contact your Andrew account representative regarding your special needs.

### *Enduring Design*

Precision formed aluminum reflectors, extensive use of hot-dipped galvanized steel, stainless steel and high tensile friction-type hardware ensures extended system operational life, increased antenna pointing accuracy under extreme climatic conditions and continued system reliability with minimum maintenance.

### *Performance*

Andrew earth station antenna systems are guaranteed to perform to published specifications. This performance guarantee ensures that specified standards of performance are met or exceeded.

All Andrew earth station antennas include a three-year limited warranty which is the longest in the industry.

### *Single-Source*

Andrew offers a complete line of earth station antenna products and systems from a single-source. This single point of contact saves time, money and simplifies system implementation. Comprehensive system design, installation and testing from one source assures total system compatibility, ultimate operational performance and complete adaptability for future system expansion.

### *Expandability, Compatibility, Flexibility*

A variety of electronic equipment has been tested and verified for quality and performance. This equipment, when pulled together by the Andrew ESA Systems Team, assures that the system provides the performance you expect from Andrew.

Modular options and accessories increase system flexibility and operational capability. We can configure your system to provide transmit, receive, receive/transmit, video, audio, or data capabilities, in single or in combination, digital or analog.

### *Services*

Round out your system package with full service program management, design, documentation, installation, and testing. The Andrew comprehensive service philosophy guarantees the final turnkey system solution meets or exceeds specified requirements.

### *Satisfaction*

Andrew designs each system individually, engineering, installing and testing to meet or exceed customer requirements and system specifications. Andrew ESA satellite communications systems deliver the ultimate in performance and dependability in a single cost-effective package.

### *Customer Support Services*

Every Andrew ESA is backed by more than a quarter century of technical experience and expertise. More importantly, Andrew offers its customers a toll-free technical support number that operates 24 hours a day, 7 days a week.

### *Faster, Easier Installation*

Andrew antennas are specifically engineered to simplify and quicken installation, resulting in significant cost savings to our customers.



3.7-Meter Pipe Mount – E-2 Type Approved,  
Eutelsat and Asiasat



4.9-Meter – Pedestal Mount



7.3-Meter – F-3 Type Approved



Earth Station Antenna Products and Systems

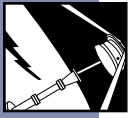

# Earth Station Antenna Quick-Reference Guide



1.2-Meter  
Ku- or K-Band  
Transportable SNG Antenna



2.4-Meter  
Ku-Band  
Transportable SNG Antenna



3.7-Meter  
C-, X- or Ku-Band  
Transportable Antenna



4.5-Meter  
C-, X- or Ku-Band  
Transportable Antenna



1.2- thru 3.6-Meter  
C-, UC or Ku-Band  
ValuStar™ Earth Station Antenna



3.7-Meter  
C-, X-, Ku-, K- or Ka-Band  
Pedestal Mount



3.7-Meter  
C-, X-, Ku-, K- or Ka-Band  
Pipe Mount



3.9-Meter  
C-, X-, Ku- or K-Band



4.5-Meter  
C-, X- or Ku-Band



4.9-Meter  
C-, X-, Ku- or K-Band



5.6-Meter  
Ku-, K- or Ka-Band



6.5-Meter  
C-, X-, Ku- or K-Band



7.3-Meter  
C- and/or Ku-Band



7.6-Meter  
C-, X-, Ku- or K-Band



9.3-Meter  
C-Band

# Earth Station Antenna Quick-Reference Guide

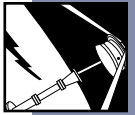

Size	Band	Tx Gain, dBi †	Rx Gain, dBi †	G/T*	Type Approval	Meets or Exceeds the Following Standards
1.2 m	C/UC/Ku	On Application	Refer to following pages	–	–	ITU-R, S.580-5 and S.465-5
1.8 m	C/UC/Ku	On Application	Refer to following pages	–	–	ITU-R, S.580-5 and S.465-5
2.4 m	C/UC/Ku	On Application	Refer to following pages	–	–	ITU-R, S.580-5 and S.465-5
3.0 m	C/UC/Ku	On Application	Refer to following pages	–	–	ITU-R, S.580-5 and S.465-5
3.6 m	C/UC/Ku	On Application	Refer to following pages	–	–	ITU-R, S.580-5 and S.465-5
3.7 m	C	46.3	42.5	23.6	–	INTELSAT F-1, G; ITU-R, Russian Homologation
	X	48.4	47.9	26.6**	–	
	Ku	53.0	51.6	30.3	INTELSAT E-2, E-1 G, ASIASAT and APSTAR	INTELSAT E-2, E-1, G; FCC, ITU-R, EUTELSAT, Russian Homologation
	Ka	On Application	On Application	On Application	–	
3.9 m	C	46.4	42.7	24.2	F-1 Pending	INTELSAT F-1, G; FCC, ITU-R
	X	48.6	47.9	26.8**	–	
	Ku	53.2	51.9	31.0	E-2 Pending	INTELSAT E-2, E-1, G; FCC, ITU-R
	K	55.0	52.0	31.0	–	
4.5 m	C	46.3	43.9	25.0	–	INTELSAT F-1, G; FCC, ITU-R, Russian Homologation
	UC	46.5	44.2	25.0	–	
	X	49.5	48.7	27.2**	–	
	Ku	53.6	52.4	30.8	–	INTELSAT E-2, E-1, G; FCC, ITU-R, Russian Homologation
4.9 m	C	48.2	44.3	24.0	F-1 Pending	INTELSAT F-1, G; FCC, ITU-R
	X	50.2	49.7	29.7**	–	
	Ku	55.2	53.9	33.0	E-2 Pending	INTELSAT E-2, E-1, G; ITU-R
	K	57.2	54.0	33.0	–	
5.6 m	Ku	57.0	55.5	34.0	–	INTELSAT E-3, E-2, E-1, G; FCC, ITU-R,
	K	58.0	56.0	34.0	–	EUTELSAT, Russian Homologation
	Ka	On Application	On Application	On Application	–	
6.5 m	C	51.0	47.4	29.0	F-2 Pending	INTELSAT E-3, F-2, FCC, ITU-R, EUTELSAT, Russian Homologation
	UC	52.0	48.0	30.0	–	
	Ku	57.5	56.3	34.9	E-3 Pending	
	K	62.0	60.0	37.5	–	
7.3 m	C	51.8	48.6	30.3	INTELSAT F-3,	INTELSAT F-3, F-2, G; FCC, ITU-R,
	UC	52.8	49.2	30.9	F-2, F-1, and G	EUTELSAT, Russian Homologation
	C	–	48.0	28.2	–	Receive-Only
7.6 m	Ku	–	55.0	33.0	–	Receive-Only
	C	52.7	48.7	29.7	–	INTELSAT F-3, F-2, F-1, D, G; FCC, ITU-R, EUTELSAT, Russian Homologation
	UC	53.7	49.3	30.3	–	
	X	54.7	54.2	33.1**	–	
	Ku	59.4	57.8	36.1	–	INTELSAT E-3, E-2, E-1, G; FCC, ITU-R, EUTELSAT, Russian Homologation
9.3 m	K	60.4	57.8	36.1	–	
	C	54.0	51.5	32.4	–	INTELSAT B, F-3, F-2, F-1, D-2; G; FCC, ITU-R, EUTELSAT, Russian Homologation
	UC	55.0	52.1	33	–	
	X	56.0	55.0	34**	–	

† Center frequency with 2-port feed. \*G/T is considered using a 2-port linearly-polarized antenna configuration at 4 GHz, C-band with a 35K LNA or at 12GHz, Ku-band with a 60K LNA; minimum elevation angle is 10° unless noted otherwise. \*\*G/T is considered using a 2-port circularly-polarized antenna configuration at 7.50 GHz and at 10° elevation with a 50K LNA.

All designs, specifications and availabilities of products and services presented are subject to change without notice.



## ValuStar™ Earth Station Antennas



1.2-Meter ValuStar™ Antenna with Optional MNT18 Mount

### **ValuStar™ 1.2-/1.8-/2.4-/3.0-/3.6-Meter Earth Station Antennas**

#### **Features:**

- C 3.625-4.2 GHz  
UC 4.5-4.8 GHz  
Ku 10.7-12.75 GHz
- Dual-Polarized, High Gain
- R/T Version on Application
- 125 mph (200 km/h) Wind Survival in any Position
- Anti-icing Options
- Fast, Simple Installation

ValuStar™ antennas from Andrew are small-diameter, superior quality, earth station antennas for professional services where reliability and durability are essential. They are ideal for broadcast distribution applications.

ValuStar antennas are available in sizes from 1.2- to 3.6-meters and feature an interchangeable, high performance, dual-polarized receive-only feed system that provides optimum gain.

To reduce overall project costs and allow local product manufacture and labor content, the basic antenna is provided with a high-quality azimuth/elevation mount. This mount can be connected to either an Andrew provided (vertical) pipe, or a customer provided (vertical) pipe, and can be held in the vertical position by casting it into a concrete foundation. An optional mount can be offered to bolt to a foundation or other suitable mounting structure.

The antennas use rugged, high accuracy, spun aluminum reflectors which are conversion coated and painted white.

Hot-dip galvanizing of the steel mount parts and careful choice of all materials ensure reliable performance and long life in adverse environments.



**Electrical**

Antenna Type	ES12	ES18	ES24	ES30	ES36
Diameter, meters	1.2	1.8	2.4	3.0	3.6
<b>Gain, dBi with 2-port combiner</b>					
3.625	30.7	34.3	37.0	38.8	39.6
4.000	31.4	35.0	37.7	39.5	40.3
4.200	31.8	35.4	37.8	40.0	41.3
4.500	32.4	36.0	38.7	40.5	41.9
4.650	32.7	36.3	39.0	40.8	42.2
4.800	33.0	36.6	39.3	41.1	42.5
10.70	40.0	43.6	46.3	48.2	49.4
10.95	40.2	43.8	46.5	48.4	49.6
11.95	40.8	44.4	47.2	49.0	50.2
12.75	41.6	45.1	48.0	49.8	50.9
VSWR, maximum	1.3	1.3	1.3	1.3	1.3
Cross Polar Discrimination (linear), dB	30	30	30	30	30
Voltage Axial Ratio (circular)	1.3	1.3	1.3	1.3	1.3
3 dB Beamwidth, degrees	C UC Ku 4.7 4.0 1.7	C UC Ku 3.1 2.7 1.0	C UC Ku 2.4 2.0 0.75	C UC Ku 1.9 1.6 0.60	C UC Ku 1.6 1.3 0.50
ES12 - Noise Temperature, K	C-Band 2-Port Linear/Circular		UC 2-Port Linear		Ku-Band 2-Port Linear
at 10 degrees elevation	42K		43K		58K
at 30 degrees elevation	33K		34K		49K
at 50 degrees elevation	29K		30K		45K
ES18 - Noise Temperature, K	C-Band 2-Port Linear/Circular		UC 2-Port Linear		Ku-Band 2-Port Linear
at 10 degrees elevation	36K		37K		50K
at 30 degrees elevation	29K		30K		42K
at 50 degrees elevation	25K		26K		38K
ES24 - Noise Temperature, K	C-Band 2-Port Linear/Circular		UC 2-Port Linear		Ku-Band 2-Port Linear
at 10 degrees elevation	31K		32K		43K
at 30 degrees elevation	24K		25K		35K
at 50 degrees elevation	20K		21K		31K
ES30 - Noise Temperature, K	C-Band 2-Port Linear/Circular		UC 2-Port Linear		Ku-Band 2-Port Linear
at 10 degrees elevation	25K		26K		35K
at 30 degrees elevation	18K		19K		26K
at 50 degrees elevation	14K		15K		22K
ES36 - Noise Temperature, K	C-Band 2-Port Linear/Circular		UC 2-Port Linear		Ku-Band 2-Port Linear
at 10 degrees elevation	29K		30K		41K
at 30 degrees elevation	22K		23K		32K
at 50 degrees elevation	18K		19K		28K

All of the above models include an az/el mount that interfaces to a customer-provided pipe or the MNT series of pipe.

**Mechanical**

Antenna Type	ES12	ES18	ES24	ES30	ES36
Survival Wind Rating, mph (km/h)	125 (200)	125 (200)	125 (200)	125 (200)	125 (200)
<b>Mount Adjustment Range</b>					
Elevation, degrees					
Coarse	0-90	0-90	0-90	0-90	0-90
Fine	± 7.5	± 7.5	± 7.5	± 7.5	± 7.5
Azimuth, degrees					
Coarse	360	360	360	360	360
Fine	± 7.5	± 7.5	± 7.5	± 7.5	± 7.5
Net Weight, lb (kg)	122 (55)	136 (62)	616 (280)	682 (310)	1067 (485)
Standard Reflector – Vertical Configuration	One-Piece	One-Piece	One-Piece	Two-Piece	Two-Piece
Mounting Pipe Size Needed, Nominal	4.5"	4.5"	6.625"	6.625"	6.625"

Surface anti-icing options: Antenna reflector surface anti-icing systems are available to prevent snow and ice from forming that would otherwise accumulate on the antenna reflector and affect the signal quality. These systems heat a 360 degree region of the reflector and come supplied with a precipitation sensing device, a temperature sensing control unit and all inter-connecting cables. In addition, a dish center heater is available, for use where ice and snow conditions may be severe.

**Antenna Accessories**

- Factory Feed System Testing and Documentation
- Ocean Transport Packing
- Anti-Icing and Deicing
- Grounding Kit
- LNA Support Kits

All designs, specifications and availabilities of products and services presented are subject to change without notice.

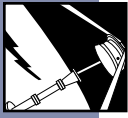

## 3.7-Meter Dual-Reflector C-, X-, Ku- or K-Band



3.7-Meter Pipe Mount

3.7-Meter Pedestal Mount

### Features:

- *High Gain, Excellent Pattern Characteristics*
- *Gregorian Optics*
- *Self-Aligning Main Reflector – No Field Alignment*
- *Field Changeable Feed System, C-Band, Circular to Linear*
- *Ka-Band Operation on Application*
- *3-Year Warranty on All Structural Components*
- *High Wind (180 mph - 288 km/h) Option*
- *MPJ Versions Supplied with 20,000 Pound Jacks for Both Az and El Axis*

### Compliances and Type Approvals:

- *APSTAR*
- *ASIASAT*
- *BRASILSAT*
- *INTELSAT F-1 compliant*
- *INTELSAT (IA012A00) or (IA012B00), E2, G*
- *EUTELSAT (EA-A002 or EA-A014)*
- *ITU-R, S.580-5 and S.465-5*
- *U. S. FCC Regulation 25.209*
- *Approved for use in the Territory of Russia by the Ministry of Communications of the Russian Federation (Reference: Homologation Certificate No OC/I-A -f-1)*

Now communications system integrators and designers can bring their systems on line faster, more economically, and with superior performance with Andrew 3.7-meter Earth Station Antenna (ESA). The Andrew 3.7-meter ESA features advanced dual-reflector technology together with a two-piece precision spun aluminum reflector assembly.

This combination provides extremely accurate surface contour, exceptionally high gain, superior efficiency, and closely controlled pattern characteristics.

Our wide selection of type approved antennas speeds system commissioning. The Andrew 3.7 Type Approved ESA can be deployed in the field with minimal testing of G/T to become fully certified as an INTELSAT standard E-2, E-1 station.

Andrew ESAs provide maximum durability with minimal maintenance. The hot-dipped galvanized steel ground mount assembly ensures extended product life. Galvanized and stainless steel hardware maximize corrosion resistance. The easily installed pedestal or pipe mount allows for non-critical foundation orientation.

The 2-port C-Band Circular R/T feed system is manually field switchable from circular to linear polarization. The 48 inch (1219 mm) diameter by 24 inch (610 mm) equipment enclosure with doors allows hub mounting of LNA systems.\*\*

For cost effective system expansion, modular equipment options include 2- or 4-port\* combining network configurations, dual-speed motor drive systems for worldwide applications, feed rotation systems\*, anti-icing equipment, and pressurization systems. Microprocessor steptack control and motorizable mount options are also available.

\* Ku- and K-Band Only.

\*\* Enclosure Available on Pedestal Mounts Only.

### Antenna Accessories

- Factory Feed System Testing and Documentation*
- Transmit Waveguide Kits, Cross-Axis Az/El/Pol*
- Motorization Kits*
- Geostationary Indoor Antenna Positioner with 40 Satellite Memory*
- Inclined Orbit Tracking Indoor Antenna Positioner (steptack)*
- Anti-Icing and Deicing*
- LNA Support Kits*
- Ocean Transport Packing*
- Grounding Kit*
- Foundation Kit*
- Lightning Rod Kit*
- Obstruction Warning Light Kit*
- Cable-Mounting Kit*
- Major Subsystem Spare Part Kits*
- Az/El Vernier Kits*
- Hub Ventilation Kit*



## Electrical Specifications

Operating Frequency Band	
C-Band Receive	3.4-4.2 GHz
C-Band Transmit	5.850-6.725 GHz
X-Band Receive	7.25-7.75 GHz
X-Band Transmit	7.90-8.40 GHz
K- & Ku-Band Receive	10.7-13.25 GHz
Ku-Band Transmit	13.75-14.8 GHz
K-Band Transmit	17.3-18.4 GHz

Gain, with 2 port linear combiner (dBi, ±0.2 dB)			
Rx Frequency	Rx Gain	Tx Frequency	Tx Gain
3.400 GHz	41.0	5.850 GHz	45.9
3.625 GHz	41.6	6.175 GHz	46.4
4.000 GHz	42.7	6.425 GHz	46.6
4.200 GHz	43.1	6.725 GHz	46.9
7.250 GHz	47.7	7.90 GHz	48.2
7.500 GHz	47.9	8.15 GHz	48.4
7.750 GHz	48.1	8.40 GHz	48.6
10.700 GHz	50.6	13.75 GHz	52.5
10.950 GHz	50.8	14.00 GHz	52.7
11.950 GHz	51.6	14.25 GHz	52.8
12.750 GHz	52.1	14.50 GHz	53.0
		14.80 GHz	53.2
		17.30 GHz	54.8
		18.40 GHz	55.2

**Polarization**  
 C-Band is circular, (switchable to linear) or linear only;  
 X-Band is circular; Ku-Band is linear; K-Band is linear or circular

**Polarization Discrimination, (Linearly-Polarized):**  
 >35 dB across 1 dB beamwidth - C- or Ku-Band or K-Band

**Voltage Axial Ratio, (Circularly-Polarized)** across the 1 dB beamwidth  
 C-Band, <1.09:1 Tx  
 <1.20:1 Rx  
 X-Band, <1.20:1 Tx and Rx

Beamwidth, Mid-band, Degrees				
	C-Band	Ku-Band	X-Band	K-Band
3 dB Receive (Transmit)	1.20 (0.80)	0.42 (0.36)	0.65 (0.60)	0.42 (0.30)
15 dB Receive (Transmit)	2.0 (1.40)	0.85 (0.69)	1.19 (1.09)	0.85 (0.60)

**Antenna Noise Temperature** – under clear sky conditions, at 68°F (20°C), with 2-port combiner.

Elevation	Kelvin (C-Band)	Kelvin (X-Band)	Kelvin (K- & Ku-Band)
10°	43	48	52
30°	38	35	39
50°	36	33	37

**Antenna VSWR, Transmit and Receive** <1.3:1

### G/T Performance (C-Band)

LNA/LNB Noise Temperature	65K	45K	30K
ES37 G/T at 10° EL (dB/K)	22.3	23.2	24.0

Based on a 2-port, linearly-polarized antenna configuration at 4 GHz and at 10° elevation under clear sky conditions.

### G/T Performance (X-Band)

LNA/LNB Noise Temperature	100K	75K	50K
ES37 G/T at 10° EL (dB/K)	25.9	26.6	27.6

Based on a 2-port, circularly-polarized antenna configuration at 7.5 GHz and at 10° elevation under clear sky conditions.

### G/T Performance (Ku-Band and K-Band)

LNA/LNB Noise Temperature	165K	125K	90K
ES37 G/T at 10° EL (dB/K)	28.2	29.1	30.1

Based on a 2-port, linearly-polarized antenna configuration at 12 GHz and at 10° elevation under clear sky conditions.

## 3.7-Meter Dual-Reflector C-, X-, Ku- or K-Band

### Mechanical Specifications

Feed Type	Dual-Reflector, Gregorian
Reflector Material	Precision-Formed Aluminum
Reflector Segments	2
Mount Type	EI over Az, Pedestal or pipe mount
<b>Antenna Pointing Range, Coarse/(Continuous)</b>	
Elevation	0-90° (90°)
Azimuth	180° (120°)
Polarization	360° (180°)
<b>Hub/Enclosure Dimensions (when applicable) Pedestal mount only</b>	
Diameter	48 in (1.2 m)
Depth	24 in (0.6 m)
<b>Wind Loading, Survival (standard)</b>	
125 mph (200 km/h) in any position of operation	
<b>Wind Loading, Survival (optional high wind)</b>	
180 mph (288 km/h) in any position of operation	
<b>Wind Loading, Operational (motor drives)</b>	
45 mph (66 km/h), gusting to 65 mph (97 km/h)	
<b>Temperature, Operational</b> -40° to 125°F (-40° to 52°C)	
Rain	4 in (102 mm) per hour
Solar Radiation	360 BTU/hr/ft <sup>2</sup> (1135 watts/m <sup>2</sup> )
Relative Humidity	100%
Shock and Vibration	As encountered by commercial air, rail and truck shipment
Atmospheric Conditions	Moderate coastal/industrial areas. Severe conditions require additional protection.

### Typical Pedestal Mount Slab Foundation

Soil Bearing Capacity	2000 lb/ft <sup>2</sup> (14,646 kg/m <sup>2</sup> )
Reinforcing Steel	194 lb (88 kg)
Concrete Compressive Strength	3000 lb/in <sup>2</sup> (211 kg/cm <sup>2</sup> )
<b>Foundation Size:</b> REF: 203340	
Length	9.0 ft (2.74 m)
Width	9.0 ft (2.74 m)
Depth	1.0 ft (0.3 m)
Concrete Volume	3.0 yd <sup>3</sup> (2.3 m <sup>3</sup> )

### Typical Pipe Mount Slab Foundation

Soil Bearing Capacity	2000 lb/ft <sup>2</sup> (14,646 kg/m <sup>2</sup> )
Reinforcing Steel	353 lb (160 kg)
Concrete Compressive Strength	3000 lb/in <sup>2</sup> (211 kg/cm <sup>2</sup> )
<b>Foundation Size:</b> REF: 240165	
Length	10.0 ft (2.74 m)
Width	10.0 ft (2.74 m)
Depth	1.0 ft (0.3 m) to 2.5 ft (0.76 m)
Concrete Volume	5.3 yd <sup>3</sup> (4.3 m <sup>3</sup> )

### Shipping Information

Weight, Net	1750 lb (800 kg)
Shipping Weight	2670 lb (1220 kg)
Shipping Volume	530 ft <sup>3</sup> (15.0 m <sup>3</sup> )
<b>Shipping Container:</b>	
Quantity, 2	Standard 20 ft land/sea container
Quantity, 4	Standard 40 ft land/sea container

All designs, specifications and availabilities of products and services presented are subject to change without notice.



## 3.9-Meter Dual-Reflector Offset C-, X-, Ku- or K-Band



### Antenna Accessories

*Factory Feed System Testing and Documentation*  
*Transmit Waveguide Kits, Cross-Axis Az/EI/Pol*  
*Motorization Kits*  
*Geostationary Indoor Antenna Positioner with*  
*40 Satellite Memory*  
*Inclined Orbit Tracking Indoor Antenna*  
*Positioner (steptrack)*  
*Anti-Icing and Deicing*  
*LNA Support Kits*  
*Ocean Transport Packing*  
*Grounding Kit*  
*Foundation Kit*  
*Lightning Rod Kit*  
*Obstruction Warning Light Kit*  
*Cable-Mounting Kit*  
*Major Subsystem Spare Part Kits*  
*Az/EI Vernier Kits*

### Features:

- *High Gain, Excellent Pattern Characteristics*
- *Gregorian Dual-Reflector Offset Optics*
- *Self-Aligning Main Reflector – No Field Alignment*
- *Field Changeable Feed System*
- *3-Year Warranty on All Structural Components*
- *Extended C-Band*

### Compliances:

- *APSTAR*
- *ASIASAT*
- *BRASILSAT*
- *INTELSAT E-2\**
- *INTELSAT F-1\**
- *EUTELSAT*
- *U.S. FCC Regulation 25.209*
- *ITU-R, S.580-5 and S.465-5*

Andrew ESAs provide maximum durability with minimal maintenance. The hot-dipped galvanized steel ground mount assembly ensures extended product life. Galvanized and stainless steel hardware maximize corrosion resistance. The easily installed pedestal mount allows for non-critical foundation orientation.

The 2-port C-Band Circular R/T feed system is manually field switchable from circular to linear polarization.

For cost effective system expansion, modular equipment options include 2- or 4-port combining network configurations, dual-speed motor drive systems for worldwide applications, feed rotation systems, anti-icing equipment, and pressurization systems. Microprocessor steptrack control and motorizable mount options are also available.

\* Type Approval Pending

# 3.9-Meter Dual-Reflector Offset C-, X-, Ku- or K-Band



## Electrical Specifications

Operating Frequency Band	
C-Band Receive	3.4-4.2 GHz
C-Band Transmit	5.850-6.725 GHz
X-Band Receive	7.25-7.75 GHz
X-Band Transmit	7.90-8.40 GHz
K- & Ku-Band Receive	10.7-13.25 GHz
Ku-Band Transmit	13.75-14.8 GHz
K-Band Transmit	17.3-18.4 GHz

Gain, with 2 port linear combiner (dBi, ±0.2 dB)			
Rx Frequency	Rx Gain	Tx Frequency	Tx Gain
3.400 GHz	41.0	5.850 GHz	45.9
3.625 GHz	41.6	6.175 GHz	46.4
4.000 GHz	42.7	6.425 GHz	46.7
4.200 GHz	43.1	6.725 GHz	47.1
7.250 GHz	47.6	7.90 GHz	48.3
7.500 GHz	47.9	8.15 GHz	48.6
7.750 GHz	48.2	8.40 GHz	48.9
10.700 GHz	50.9	13.75 GHz	52.9
10.950 GHz	51.1	14.00 GHz	53.1
11.950 GHz	51.9	14.25 GHz	53.2
12.750 GHz	52.4	14.50 GHz	53.4
		14.80 GHz	53.6
		17.30 GHz	54.8
		18.40 GHz	55.2

Polarization
C-Band is circular, (switchable to linear) or linear only; X-Band is circular; Ku-Band is linear; K-Band is linear or circular

Polarization Discrimination, (Linearly-Polarized):
>35 dB across 1 dB beamwidth - C- or Ku-Band or K-Band

Voltage Axial Ratio, (Circularly-Polarized) across the 1 dB beamwidth
C-Band, <1.09:1 Tx <1.20:1 Rx
X-Band, <1.20:1 Tx and Rx

Beamwidth, Mid-band, Degrees				
	C-Band	Ku-Band	X-Band	K-Band
3 dB Receive (Transmit)	1.30 (0.80)	0.48 (0.40)	0.66 (0.60)	0.48 (0.32)
15 dB Receive (Transmit)	2.80 (1.72)	0.96 (0.84)	1.38 (1.28)	0.96 (0.68)

Antenna Noise Temperature – under clear sky conditions, at 68°F (20°C), with 2-port combiner.			
Elevation	Kelvin (C-Band)	Kelvin (X-Band)	Kelvin (K- & Ku-Band)
10°	34	38	41
30°	26	27	27
50°	24	25	25

Antenna VSWR, Transmit and Receive	
	<1.3:1

## G/T Performance (C-Band)

LNA/LNB Noise Temperature	65K	45K	30K
ES39 G/T at 10° EL (dB/K)	22.7	23.7	24.6

Based on a 2-port, linearly-polarized antenna configuration at 4 GHz and at 10° elevation under clear sky conditions.

## G/T Performance (X-Band)

LNA/LNB Noise Temperature	100K	75K	50K
ES39 G/T at 10° EL (dB/K)	26.5	27.3	28.4

Based on a 2-port, circularly-polarized antenna configuration at 7.5 GHz and at 10° elevation under clear sky conditions.

## G/T Performance (Ku-Band and K-Band)

LNA/LNB Noise Temperature	165K	125K	90K
ES39 G/T at 10° EL (dB/K)	23.1	29.7	30.7

Based on a 2-port, linearly-polarized antenna configuration at 12 GHz and at 10° elevation under clear sky conditions.

## Mechanical Specifications

Feed Type	Dual-Reflector, Gregorian
Reflector Material	Precision-Formed Aluminum
Reflector Segments	6
Mount Type	El over Az, pipe mount

Antenna Pointing Range, Coarse/(Continuous)	
Elevation	0-90° (90°)
Azimuth	360° (20°) manual
Polarization	360° (180°)

Wind Loading, Survival (standard)	
	125 mph (200 km/h) in any position of operation

Wind Loading, Operational (motor drives)	
	45 mph (66 km/h), gusting to 65 mph (97 km/h)

Temperature, Operational	
	-40° to 125°F (-40° to 52°C)

Rain	
	4 in (102 mm) per hour

Solar Radiation	
	360 BTU/hr/ft <sup>2</sup> (1135 watts/m <sup>2</sup> )

Relative Humidity	
	100%

Shock and Vibration	
	As encountered by commercial air, rail and truck shipment

Atmospheric Conditions	
	Moderate coastal/industrial areas. Severe conditions require additional protection.

## Typical Pedestal Mount Slab Foundation

Soil Bearing Capacity	2000 lb/ft <sup>2</sup> (14,646 kg/m <sup>2</sup> )
Reinforcing Steel	640 lb (290 kg)
Concrete Compressive Strength	3000 lb/in <sup>2</sup> (211 kg/cm <sup>2</sup> )
Foundation Size:	REF: 203340
Length	11.0 ft (3.3 m)
Width	11.0 ft (3.3 m)
Depth	18 in (0.5 m)
Concrete Volume	6.72 yd <sup>3</sup> (5.1 m <sup>3</sup> )

## Shipping Information

Weight, Net	1500 lb (680 kg)
Shipping Weight	2500 lb (1134 kg)
Shipping Volume	500 ft <sup>3</sup> (14 m <sup>3</sup> )
Shipping Container:	
Quantity, 2	Standard 20 ft land/sea container
Quantity, 4	Standard 40 ft land/sea container

All designs, specifications and availabilities of products and services presented are subject to change without notice.



## 4.5-Meter C-, X- or Ku-Band



4.5-Meter Pedestal Mount



4.5-Meter Tripod Mount

### Antenna Accessories

- Factory Feed System Testing and Documentation*
- Transmit Waveguide Kits, Cross-Axis Az/EI/Pol*
- Motorization Kits*
- Geostationary Indoor Antenna Positioner with 40 Satellite Memory*
- Inclined Orbit Tracking Indoor Antenna Positioner (steprack)*
- Anti-Icing and Deicing*
- LNA Support Kits*
- Ocean Transport Packing*
- Grounding Kit*
- Foundation Kit*
- Lightning Rod Kit*
- Obstruction Warning Light Kit*
- Cable-Mounting Kit*
- Major Subsystem Spare Part Kits*
- Az/EI Vernier Kits*

### Features:

- *High Gain, Excellent Pattern Characteristics*
- *Main Reflector – No Special Field Alignment*
- *3-Year Warranty on All Structural Components*
- *MPJ Versions Supplied with 20,000 Pound Jacks for Both Az and EI Axis*

### Compliances:

- *APSTAR*
- *ASIASAT*
- *BRASILSAT*
- *INTELSAT E-2, E-1, F-1, G*
- *U.S. FCC Regulation 25.209*
- *ITU-R, S.580-5 and S.465-5*
- *Approved for use in the Territory of Russia by the Ministry of Communications of the Russian Federation (Reference: Homologation Certificate No OC/I-A -f-1)*

Now communications system integrators and designers can bring their systems on line faster, more economically, and with superior performance with the Andrew 4.5-meter Earth Station Antenna (ESA). In use around the world in high-density data, voice, communications networks, and broadcast applications, the Andrew 4.5-meter ESA features an exclusively designed 2- or 4-port prime focus, beam-shaping feed and ground plane configuration. This combination provides extremely accurate surface contour, exceptionally high gain, superior efficiency, and closely controlled pattern characteristics. The antenna is versatile, and can be configured for transmit/receive as well as receive-only, and for either linearly- or circularly-polarized C-Band, linearly-polarized Ku-Band, Hybrid C-/Ku-Band, or X-Band operation. Both pedestal and tripod mount types are available (motorization for pedestal only).

Andrew 4.5-meter ESAs feature exceptionally easy and accurate assembly. When using our optional hoisting kit no crane is necessary for installation. Additionally, the main reflector requires no special field alignment.

Andrew ESAs provide maximum durability with minimal maintenance. The hot-dipped galvanized steel ground mount assembly ensures extended product life. Galvanized and stainless steel hardware maximize corrosion resistance. For cost effective system expansion, available modular equipment options include anti-icing equipment and pressurization systems. Microprocessor steprack control and motorizable mount options are also available.

## 4.5-Meter C-, X- or Ku-Band



### Electrical Specifications

Operating Frequency Band	
C-Band Receive	3.4-4.2 GHz
C-Band Transmit	5.850-6.725 GHz
X-Band Receive	7.25-7.75 GHz
X-Band Transmit	7.90-8.40 GHz
Ku-Band Receive	10.7-13.25 GHz
Ku-Band Transmit	13.75-14.8 GHz

Gain, with 2 port linear combiner (dBi, ±0.2dB)			
Rx Frequency	Rx Gain	Tx Frequency	Tx Gain
3.400 GHz	42.4	5.850 GHz	46.0
3.625 GHz	42.8	6.175 GHz	46.3
4.000 GHz	43.9	6.425 GHz	46.6
4.200 GHz	44.2	6.725 GHz	47.0
7.250 GHz	48.4	7.90 GHz	49.2
7.500 GHz	48.7	8.15 GHz	49.5
7.750 GHz	49.0	8.40 GHz	49.8
10.700 GHz	51.4	13.75 GHz	53.2
10.950 GHz	51.6	14.00 GHz	53.4
11.950 GHz	52.4	14.25 GHz	53.6
12.750 GHz	52.9	14.50 GHz	53.7
13.25 GHz	53.2	14.80 GHz	53.8

**Polarization**  
Linearly- or Circularly-Polarized

**Polarization Discrimination**, (Linearly-Polarized):  
>35 dB on axis

**Voltage Axial Ratio**, C-Band, circularly-polarized with 2-port combiner  
C-Band, <1.09:1 on axis, Tx  
<1.20:1 on axis, Rx  
X-Band, <1.20:1 on axis, Tx and Rx

Beamwidth, Mid-band, Degrees			
	C-Band	X-Band	Ku-Band
3 dB Receive (Transmit)	1.22 (0.85)	0.66 (0.60)	0.40 (0.35)
15 dB Receive (Transmit)	2.47 (1.90)	1.40 (1.29)	0.84 (0.67)

**Antenna Noise Temperature** – under clear sky conditions, at 68°F (20°C), at the circular waveguide flange of the feed.

Elevation	Kelvin (C-Band)	Kelvin (X-Band)	Kelvin (Ku-Band)
10°	44	45	53
30°	32	34	41
50°	28	29	38

**Antenna VSWR, Transmit and Receive** <1.3:1

### G/T Performance (C-Band)

LNA/LNB Noise Temperature	65K	45K	30K
ES45 G/T at 10° EL (dB/K)	23.4	24.3	25.0

Based on a 2-port, linearly-polarized antenna configuration at 4 GHz and at 10° elevation under clear sky conditions.

### G/T Performance (X-Band)

LNA/LNB Noise Temperature	100K	75K	50K
ES45 G/T at 10° EL (dB/K)	26.5	27.2	28.1

Based on a 2-port, circularly-polarized antenna configuration at 7.5 GHz and at 10° elevation under clear sky conditions.

### G/T Performance (Ku-Band)

LNA/LNB Noise Temperature	165K	125K	90K
ES45 G/T at 10° EL (dB/K)	29.1	29.9	30.8

Based on a 2-port, circularly-polarized antenna configuration at 12 GHz and at 10° elevation under clear sky conditions.

### Uplink EIRP Capability (C-Band)

HPA Output (watts)	25	125	500
Uplink EIRP (dBW)	60.5	67.5	73.5

Based on a 2-port antenna configuration at 6.175 GHz and 0 dB allowance for waveguide (IFL) loss between the HPA and the antenna.

### Uplink EIRP Capability (X-Band)

HPA Output (watts)	25	125	500
Uplink EIRP (dBW)	63.3	69.3	75.3

Based on a 2-port antenna configuration at 8.15 GHz and 0 dB allowance for waveguide (IFL) loss between the HPA and the antenna.

### Uplink EIRP Capability (Ku-Band)

HPA Output (watts)	25	125	500
Uplink EIRP (dBW)	60.5	67.5	73.5

Based on a 2-port antenna configuration at 6.175 GHz and 0 dB allowance for waveguide (IFL) loss between the HPA and the antenna.

### Mechanical Specifications

Feed Type	Prime Focus
Reflector Material	Precision-Formed Aluminum
Reflector Segments	6
Mount Type	EI over Az, Manual Tripod or Pedestal

Antenna Pointing Range, Pedestal Mount Coarse/(Continuous)	
Elevation	0-90° (90°)
Azimuth	180° (120°)

Antenna Pointing Range, Tripod Mount Coarse/(Continuous)	
Elevation (Standard)	2-62° (15°)
Elevation (Extended)	33-90° (15°) optional
Azimuth	164° (15°)

**Wind Loading, Survival**  
125 mph (200 km/h) in any position of operation

**Wind Loading, Operational (pedestal motorized)**  
45 mph (72 km/h), gusting to 65 mph (105 km/h) (motor drives)

**Temperature, Operational** -40° to 125°F (-40° to 52°C)

**Rain** 4 in (102 mm) per hour

**Solar Radiation** 360 BTU/hr/ft<sup>2</sup> (1135 watts/m<sup>2</sup>)

**Relative Humidity** 100%

**Shock and Vibration** As encountered by commercial air, rail and truck shipment

**Atmospheric Conditions** Moderate coastal/industrial areas. Severe conditions require additional protection.

### Pedestal/Tripod Slab Foundation

**Soil Bearing Capacity** 2000 lb/ft<sup>2</sup> (9770 kg/m<sup>2</sup>)

**Reinforcing Steel** 284 lb (129 kg)

**Concrete Compressive Strength** 3000 lb/in<sup>2</sup> (211 kg/cm<sup>2</sup>)

Foundation Size:	
Length	10.0 ft (3.05 m)
Width	10.0 ft (3.05 m)
Depth	18 in (0.5 m)
Concrete Volume	5.56 yd <sup>3</sup> (4.25 m <sup>3</sup> )

### Shipping Information

Shipping Weight	
4.5 m (P, MP, MPJ Types)	6000 lb (2722 kg)
4.5 m (T Types) Tripod	5600 lb (2540 kg)

**Shipping Volume** 690 ft<sup>3</sup> (19.5 m<sup>3</sup>)

Shipping Container	
4.5 m (P, MP, MPJ Types)	
Quantity 2	Standard 20 ft land/sea container
Quantity 5	Standard 40 ft land/sea container
4.5 m (T Types)	
Quantity 2	Standard 20 ft land/sea container
Quantity 5	Standard 40 ft land/sea container

All designs, specifications and availabilities of products and services presented are subject to change without notice.



## 4.9-Meter Dual-Reflector C-, X-, Ku- or K-Band



### Antenna Accessories

*Factory Feed System Testing and Documentation*  
*Transmit Waveguide Kits, Cross-Axis Az/EI/Pol*  
*Motorization Kits*  
*Geostationary Indoor Antenna Positioner with*  
*40 Satellite Memory*  
*Inclined Orbit Tracking Indoor Antenna*  
*Positioner (steptrack)*  
*Anti-Icing and Deicing*  
*LNA Support Kits*  
*Ocean Transport Packing*  
*Grounding Kit*  
*Foundation Kit*  
*Lightning Rod Kit*  
*Obstruction Warning Light Kit*  
*Cable-Mounting Kit*  
*Major Subsystem Spare Part Kits*  
*Az/EI Vernier Kits*

### Features:

- *High Gain, Excellent Pattern Characteristics*
- *Gregorian Optics*
- *3-Year Warranty on All Structural Components*
- *Self-Aligning Main Reflector – No Field Alignment*
- *Field Changeable Feed System, C-Band, Circular to Linear*

### Compliances:

- *APSTAR*
- *ASIASAT*
- *INTELSAT F-1\**
- *INTELSAT E-2\**
- *EUTELSAT*
- *ITU-R, S.580-5 and S.465-5*
- *U. S. FCC Regulation 25.209 at Ku-Band*

Now communications system integrators and designers can bring their systems on line faster, more economically, and with superior performance with Andrew 4.9-meter Earth Station Antenna (ESA). The Andrew 4.9-meter ESA features uniquely formed dual reflector Gregorian system coupled with close-tolerance manufacturing techniques. This combination provides extremely accurate surface contour, exceptionally high gain, superior efficiency, and closely controlled pattern characteristics.

Our wide selection of type approved antennas speeds system commissioning.

The 2-port C-Band Circular R/T feed system is manually field switchable from circular to linear polarization. The 48 inch (1219 mm) diameter by 32 inch (813 mm) equipment enclosure with doors allows hub mounting of LNA systems.

Andrew ESAs provide maximum durability with minimal maintenance. The hot-dipped galvanized steel ground mount assembly ensures extended product life. Galvanized and stainless steel hardware maximize corrosion resistance. For cost effective system expansion, available modular equipment options include anti-icing equipment and pressurization systems. Microprocessor steptrack control and motorizable mount options are also available.

\* Type Approval Pending

## 4.9-Meter Dual-Reflector C-, X-, Ku- or K-Band

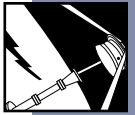

### Electrical Specifications

Operating Frequency Band	
C-Band Receive	3.4-4.2 GHz
C-Band Transmit	5.850-6.725 GHz
X-Band Receive	7.25-7.75 GHz
X-Band Transmit	7.90-8.40 GHz
K- and Ku-Band Receive	10.7-13.25 GHz
Ku-Band Transmit	13.75-14.8 GHz
K-Band Transmit	17.3-18.4 GHz

Gain, with 2 port linear combiner (dBi, ±0.2 dB)			
Rx Frequency	Rx Gain	Tx Frequency	Tx Gain
3.400 GHz	43.0	5.850 GHz	47.8
3.625 GHz	43.7	6.175 GHz	48.2
4.000 GHz	44.3	6.425 GHz	48.6
4.200 GHz	44.7	6.725 GHz	48.7
7.250 GHz	49.5	7.90 GHz	50.0
7.500 GHz	49.7	8.15 GHz	50.2
7.750 GHz	49.9	8.40 GHz	50.6
10.700 GHz	52.9	13.75 GHz	54.9
10.950 GHz	53.1	14.00 GHz	55.0
11.950 GHz	53.9	14.25 GHz	55.2
12.750 GHz	54.4	14.50 GHz	55.3
		14.80 GHz	55.5
		17.30 GHz	57.0
		18.40 GHz	57.5

Polarization
C-Band is circular, (switchable to linear) or linear only; X-Band is circular; Ku-Band is linear; K-Band is linear or circular

Polarization Discrimination, (Linearly-Polarized):
>35 dB across 1 dB beamwidth - C- or Ku-Band or K-Band

Voltage Axial Ratio, (Circularly-Polarized) across the 1 dB beamwidth	
C-Band,	<1.09:1 Tx <1.20:1 Rx
X-Band,	<1.20:1 Tx and Rx

Beamwidth, Mid-band, Degrees				
	C-Band	Ku-Band	X-Band	K-Band
3 dB Receive (Transmit)	0.98 (0.63)	0.32 (0.29)	0.51 (0.47)	0.32 (0.23)
15 dB Receive (Transmit)	1.90 (1.26)	0.64 (0.54)	1.01 (0.93)	0.64 (0.40)

Antenna Noise Temperature – under clear sky conditions, at 68°F (20°C), with 2-port combiner..

Elevation	Kelvin (C-Band)	Kelvin (X-Band)	Kelvin (Ku-Band)
10°	43	45	49
30°	35	35	38
50°	33	33	36

Antenna VSWR, Transmit and Receive
<1.25:1

### G/T Performance (C-Band)

LNA/LNB Noise Temperature	65K	45K	30K
ES49 G/T at 10° EL (dB/K)	23.3	24.1	24.7

Based on a 2-port, linearly-polarized antenna configuration at 4 GHz and at 10° elevation under clear sky conditions.

### G/T Performance (X-Band)

LNA/LNB Noise Temperature	100K	75K	50K
ES49 G/T at 10° EL (dB/K)	27.9	28.7	29.7

Based on a 2-port, circularly-polarized antenna configuration at 7.5 GHz and at 10° elevation under clear sky conditions.

### G/T Performance (Ku-Band)

LNA/LNB Noise Temperature	165K	125K	90K
ES49 G/T at 10° EL (dB/K)	30.2	31.1	32.0

Based on a 2-port, circularly-polarized antenna configuration at 12 GHz and at 10° elevation under clear sky conditions.

### Mechanical Specifications

Feed Type	Dual-Reflector, Gregorian
Reflector Material	Precision-Formed Aluminum
Reflector Segments	12
Mount Type	EI over Az

Antenna Pointing Range, Coarse/(Continuous)	
Elevation	0-90° (90°)
Azimuth	180° (120°)
Polarization	180° (180°)

Hub/Enclosure Dimensions	
Diameter	48 in (1.22 m)
Depth	32 in (0.81 m)

Wind Loading, Survival	
125 mph (200 km/h) in any position of operation	

Wind Loading, Operational	
45 mph (72 km/h), gusting to 65 mph (105 km/h) (motor drives)	

Temperature, Operational	
-40° to 125°F (-40° to 52°C)	

Rain	
4 in (102 mm) per hour	

Solar Radiation	
360 BTU/hr/ft <sup>2</sup> (1135 watts/m <sup>2</sup> )	

Relative Humidity	
100%	

Shock and Vibration	
As encountered by commercial air, rail and truck shipment	

Atmospheric Conditions	
Moderate coastal/industrial areas. Severe conditions require additional protection.	

### Slab Foundation Information

Soil Bearing Capacity	2000 lb/ft <sup>2</sup> (9770 kg/m <sup>2</sup> )
-----------------------	---

Reinforcing Steel	688 lb (312 kg)
-------------------	-----------------

Concrete Compressive Strength	3000 lb/in <sup>2</sup> (211 kg/cm <sup>2</sup> )
-------------------------------	---

Foundation Size:	
Length	11.6 ft (3.5 m)
Width	11.6 ft (3.5 m)
Depth	18 in (0.5 m)
Concrete Volume	7.35 yd <sup>3</sup> (5.62 m <sup>3</sup> )

### Shipping Information

Shipping Weight	4.9 m	4700 lb (2132 kg)
-----------------	-------	-------------------

Shipping Volume	720 ft <sup>3</sup> (20.4 m <sup>3</sup> )
-----------------	--

Shipping Container	4.9 m	4 per 40 ft standard container
--------------------	-------	--------------------------------

All designs, specifications and availabilities of products and services presented are subject to change without notice.

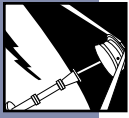

## 5.6-Meter Ku-, K- or Ka-Band



### Antenna Accessories

*Factory Feed System Testing and Documentation  
Transmit Waveguide Kits, Cross-Axis Az/EI/Pol  
Motorization Kits  
Geostationary Indoor Antenna Positioner with  
40 Satellite Memory  
Inclined Orbit Tracking Indoor Antenna  
Positioner (steptrack)  
Anti-Icing and Deicing  
LNA Support Kits  
Ocean Transport Packing  
Hub Ventilation Kit  
Grounding Kit  
Foundation Kit  
Lightning Rod Kit  
Maintenance Platform and Ladder  
Obstruction Warning Light Kit  
Cable-Mounting Kit  
Major Subsystem Spare Part Kits  
Az/EI Vernier Kits*

### Features:

- *High Gain, Excellent Pattern Characteristics*
- *Advanced Gregorian Optics*
- *Self-Aligning Main Reflector—No Field Alignment*
- *Deep Equipment Enclosure*
- *3-Year Warranty on All Structural Components*

### Compliances:

- *APSTAR*
- *ASTRA*
- *ASIASAT*
- *BRASILSAT*
- *INTELSAT E-3, E-2, E-1, G*
- *EUTELSAT*
- *FCC Regulation 25.209*
- *ITU-R, S.580-5 and S.465-5*
- *Approved for use in the Territory of Russia by the Ministry of Communications of the Russian Federation (Reference: Homologation Certificate No OC/I-A -f-1)*

Communications system integrators and designers can bring their systems on line faster, more economically, and with superior performance with the Andrew 5.6-meter Earth Station Antenna (ESA). In use worldwide in high-density data and voice communications networks and television broadcast video distribution applications, the Andrew 5.6-meter ESA features a uniquely formed dual reflector Gregorian system coupled with close-tolerance manufacturing techniques. This combination provides extremely accurate surface contour, high gain, superior efficiency, and exceptional pattern characteristics.

Our wide selection of Type Approved antennas speeds system deployment. Type Approved Andrew ESAs can be deployed in the field with minimal testing and decreased administrative and approval requirements.

Andrew ESAs provide maximum durability with minimal maintenance. The hot-dipped galvanized steel ground mount assembly ensures extended product life. Galvanized and stainless steel hardware maximize corrosion resistance. For cost effective system expansion, available modular equipment options include anti-icing equipment and pressurization systems. Microprocessor steptrack control and motorizable mount options are also available.

# 5.6-Meter Ku-, K- or Ka-Band



## Electrical Specifications

Operating Frequency Band			
Ku-Band Receive		10.7-13.25 GHz	
Ku-Band Transmit		12.75-14.8 GHz	
K-Band Transmit		17.3-18.9 GHz	
Ka-Band Receive		17.7-21.2 GHz	
Ka-Band Transmit		27.5-30.0 GHz	
Gain, with 2-port combiner (dBi, ±0.2 dB)			
Rx Frequency	Rx Gain	Tx Frequency	Tx Gain
10.700 GHz	54.5	12.750 GHz	56.1
10.950 GHz	54.7	13.250 GHz	56.3
11.950 GHz	55.5	13.75 GHz	56.6
19.250 GHz	59.2	14.25 GHz	57.0
		14.50 GHz	57.1
		18.000 GHz	58.6
		29.00 GHz	62.0
Polarization			
K-/Ku-Band	Linear		
Ka-Band	Circular		
Polarization Discrimination			
K/Ku	>35 dB across beamwidth 19 - 25 log Ø from 1.8° to 9.2°		
Ka	1.09:1 VAR		
Beamwidth, Mid-band, Degrees			
	Ku- & K-Band		Ka-Band
3 dB Receive (Transmit)	0.28 (0.23)		0.21 (0.15)
15 dB Receive (Transmit)	0.52 (0.44)		0.47 (0.34)
Antenna Noise Temperature – under clear sky conditions, at 68°F (20°C), with 2-port linear combiner.			
	Ku- & K-Band Kelvin		Ka-Band Kelvin
Elevation			
10°	49		96
30°	38		64
50°	35		59
Antenna VSWR, Transmit and Receive			<1.3:1

## G/T Performance

LNA/LNB Noise Temperature	165K	125K	90K
ES56 G/T at 10° EL (dB/K)	32.2	33.0	34.0
Based on a 2-port, linearly-polarized antenna configuration at 12 GHz under clear sky conditions.			
LNA/LNB Noise Temperature		220K	150K
ES56 G/T at 10° EL (dB/K)		33.0	35.0

Based on a 2-port, circularly-polarized antenna configuration at 19.25 GHz under clear sky conditions.

## Uplink EIRP Capability

HPA Output (watts)	75	300	2000
Uplink EIRP (dBW)	75.7	81.7	90.0
Based on a 2-port antenna configuration at 14.25 GHz and 0 dB allowance for waveguide (IFL) loss between the HPA and the antenna.			
HPA Output (watts)	50	200	500
Uplink EIRP (dBW)	79.0	85.0	89.0

Based on a 2-port antenna configuration at 29.0 GHz and 0 dB allowance for waveguide (IFL) loss between the HPA and the antenna.

## Mechanical Specifications

Feed Type	Dual-Reflector, Gregorian
Reflector Material	Precision-Formed Aluminum
Reflector Segments	16
Mount Type	EI over Az, Tripod (Ku- and K-band) Pedestal (Ka-band)
Antenna Pointing Range, Coarse/(Continuous)	
Elevation	0-90° (90°)
Azimuth	180° (120°)
Polarization	180° (180°)
Hub/Enclosure Dimensions	
Diameter	52 in (1.32 m)
Depth	46 in (1.17 m)
Wind Loading, Survival	
125 mph (200 km/h) in any position of operation (tripod)	
150 mph (240 km/h) in any position of operation (pedestal)	
Wind Loading, Operational	
45 mph (72 km/h), gusting to 65 mph (105 km/h) (motor drives)	
Temperature, Operational	
-40° to 125°F (-40° to 52°C)	
Rain	
4 in (102 mm) per hour	
Solar Radiation	
360 BTU/hr/ft <sup>2</sup> (1135 watts/m <sup>2</sup> )	
Relative Humidity	
100%	
Shock and Vibration	
As encountered by commercial air, rail and truck shipment	
Atmospheric Conditions	
Moderate coastal/industrial areas. Severe conditions require additional protection.	

## Typical Slab Foundation Information

Soil Bearing Capacity	2000 lb/ft <sup>2</sup> (9,764 kg/m <sup>2</sup> )
Reinforcing Steel	1308 lb (593 kg)
Concrete Compressive Strength	3000 lb/in <sup>2</sup> (211 kg/cm <sup>2</sup> )
Foundation Size:	
Length	14 ft (4.5 m)
Width	14 ft (4.5 m)
Depth	1.5 ft (0.5 m)
Concrete Volume	12.1 yd <sup>3</sup> (9.3 m <sup>3</sup> )

Note: Other typical foundation designs are available.

## Typical Shipping Information

Net Weight	3035 lb (1785 kg)
Gross Shipping Weight	5600 lb (2450 kg)
Shipping Volume	690 ft <sup>3</sup> (19.5 m <sup>3</sup> )
Shipping Container	
Quantity 1	Standard 20 ft land/sea container
Quantity 3	Standard 40 ft land/sea container

All designs, specifications and availabilities of products and services presented are subject to change without notice.



## 6.5-Meter Dual-Reflector C-, X-, Ku- or K-Band



### Antenna Accessories

*Factory Feed System Testing and Documentation*  
*Transmit Waveguide Kits, Cross-Axis Az/EI/Pol*  
*Motorization Kits*  
*Geostationary Indoor Antenna Positioner with*  
*40 Satellite Memory*  
*Inclined Orbit Tracking Indoor Antenna*  
*Positioner (steptrack)*  
*Anti-Icing and Deicing*  
*LNA Support Kits*  
*Ocean Transport Packing*  
*Hub Ventilation Kit*  
*Grounding Kit*  
*Foundation Kit*  
*Lightning Rod Kit*  
*Maintenance Platform and Ladder*  
*Obstruction Warning Light Kit*  
*Cable-Mounting Kit*  
*Major Subsystem Spare Part Kits*  
*Az/EI Vernier Kits*

### Features:

- *High Gain, Excellent Pattern Characteristics*
- *Advanced Gregorian Optics*
- *Self-Aligning Main Reflector – No Field Alignment*
- *Field Switchable Rx/Tx Combiner, 2-Port C-Band Circular*
- *Rugged Aluminum and Steel – 125 mph (200 kph) Wind Survival*
- *3-Year Warranty on All Structural Components*

### Compliances:

- *APSTAR*
- *ASIASAT*
- *BRAZILSAT*
- *EUTELSAT*
- *INTELSAT F-2, F-1 at C-Band, and E-3, E-2, E-1 at Ku-Band*
- *FCC Regulation 25.209, from 1° to 180°*
- *ITU-R, S.580-5 and S.465-5*

Communications system integrators and designers can now bring their systems on line faster, more economically, and with superior performance with Andrew 6.5-meter Earth Station Antennas.

Excellent for high-density data, voice, communications networks, and broadcast applications, the Andrew 6.5-meter ESA features a uniquely formed dual-reflector Gregorian system coupled with close-tolerance manufacturing techniques. This combination provides extremely accurate surface contour, exceptionally high gain, superior efficiency, and closely controlled pattern characteristics.

The 6.5-meter antenna is fully compliant with the FCC 25.209 specifications from 1° to 180° at C- and Ku-bands. Waivers are not required for routine licensing of the 6.5 meter at C-band.

The 2-port circular Rx/Tx combiners are field switchable from circular to linear polarization.

Andrew ESAs provide maximum durability with minimal maintenance. The hot-dipped galvanized steel ground mount assembly ensures extended product life. Galvanized and stainless steel hardware maximize corrosion resistance.

For cost effective system expansion, available modular equipment options include anti-icing equipment and pressurization systems. Microprocessor steptrack control and two mount options – manual only and motorizable – are also available.

# 6.5-Meter Dual-Reflector C-, X-, Ku- or K-Band

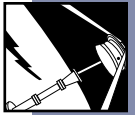

## Electrical Specifications

Operating Frequency Band			
C-Band Receive	3.400-4.2 GHz		
C-Band Transmit	5.850-6.725 GHz		
X-Band Receive	7.25-7.75 GHz		
X-Band Transmit	7.90-8.40 GHz		
Ku-Band Receive	10.7-13.25 GHz		
Ku-Band Transmit	13.75-14.8 GHz		
K-Band Transmit	17.3-18.4 GHz		
Gain, with 2-port combiner (dBi, ±0.2 dB)			
Rx Frequency	Rx Gain	Rx Frequency	Rx Gain
3.400 GHz	45.9	5.850 GHz	50.6
3.625 GHz	46.5	6.175 GHz	51.0
4.000 GHz	47.4	6.425 GHz	51.3
4.200 GHz	47.8	6.725 GHz	51.6
7.250 GHz	52.4	7.90 GHz	53.1
7.500 GHz	52.7	8.15 GHz	53.4
7.750 GHz	53.0	8.40 GHz	53.6
10.700 GHz	55.4	13.75 GHz	57.2
10.950 GHz	55.5	14.00 GHz	57.4
11.950 GHz	56.3	14.25 GHz	57.5
12.750 GHz	56.8	14.50 GHz	57.7
		14.80 GHz	57.8
		17.30 GHz	58.7
		18.40 GHz	59.2
Polarization			
C-Band	Linearly- or Circularly-Polarized		
Ku-Band	Linearly-Polarized		
X-Band	Circularly-Polarized		
Polarization Discrimination (Linearly Polarized)			
>35 dB across 1 dB beamwidth	19 - 25 log $\phi$ from 1.8° to 9.2°		
Voltage Axial Ratio, C-Band, circularly-polarized with 4-port combiner <1.06:1 across the 1 dB beamwidth <1.09 and 1.2 with 2-port			
Beamwidth, Mid-band, Degrees	C-Band	Ku- & K-Band	
3 dB Receive (Transmit)	0.68 (0.42)	0.23 (0.19)	
15 dB Receive (Transmit)	1.32 (0.84)	0.44 (0.36)	
Antenna Noise Temperature – under clear sky conditions, at 68°F (20°C), with 2-port linear combiner.			
Elevation	Kelvin (C-Band)	Kelvin (Ku- & K-Band)	
10°	39	48	
30°	29	33	
50°	26	31	
Antenna VSWR, Transmit and Receive			<1.3:1

## G/T Performance (C-Band)

LNA/LNB Noise Temperature	65K	45K	30K
ES65 G/T at 10° EL (dB/K)	27.2	28.1	29.0

Based on a 2-port, linearly-polarized antenna configuration at 4 GHz and at 10° elevation under clear sky conditions.

## G/T Performance (Ku-Band)

LNA/LNB Noise Temperature	165K	125K	90K
ES65 G/T at 10° EL (dB/K)	33.2	33.9	34.9

Based on a 2-port, linearly-polarized antenna configuration at 12 GHz and at 10° elevation under clear sky conditions.

## Uplink EIRP Capability (C-Band)

HPA Output (watts)	125	500	3000
Uplink EIRP (dBW)	72.0	78.0	85.8

Based on a 2-port antenna configuration at 6.175 GHz and 0 dB allowance for waveguide (IFL) loss between the HPA and the antenna.

## Mechanical Specifications

Feed Type	Dual-Reflector, Gregorian
Reflector Material	Precision-Formed Aluminum
Reflector Segments	16
Mount Type	EI over Az, Tripod, Manual or Motorized
Antenna Pointing Range, Coarse/(Continuous)	
Elevation	0-90° (90°)
Azimuth	180° (120°)
Polarization	180° (180°)
Hub/Enclosure Dimensions	
Diameter	52 in (1.32 m)
Depth	48.5 in (1.17 m)
Wind Loading, Survival	
125 mph (200 km/h) in any position of operation	
Wind Loading, Operational	
45 mph (72 km/h), gusting to 65 mph (105 km/h) (motor drives)	
Temperature, Operational	
-40° to 125°F (-40° to 52°C)	
Rain	
4 in (102 mm) per hour	
Solar Radiation	
360 BTU/hr/ft <sup>2</sup> (1135 watts/m <sup>2</sup> )	
Relative Humidity	
100%	
Shock and Vibration	
As encountered by commercial air, rail and truck shipment	
Atmospheric Conditions	
Moderate coastal/industrial areas. Severe conditions require additional protection.	

## Typical Slab Foundation Information

Soil Bearing Capacity	2000 lb/ft <sup>2</sup> (9,764 kg/m <sup>2</sup> )
Reinforcing Steel	1708 lb (807 kg)
Concrete Compressive Strength	3000 lb/in <sup>2</sup> (211 kg/cm <sup>2</sup> )
Foundation Size:	
Length	15.5 ft (4.7 m)
Width	15.5 ft (4.7 m)
Depth	2.0 ft (0.6 m)
Concrete Volume	17.8 yd <sup>3</sup> (13.6 m <sup>3</sup> )

## Typical Shipping Information

Net Weight	6400 lb (2903 kg)
Gross Shipping Weight	8101 lb (3675 kg)
Shipping Volume	780 ft <sup>3</sup> (22.1 m <sup>3</sup> )
Shipping Container	Standard 20 ft land/sea container

All designs, specifications and availabilities of products and services presented are subject to change without notice.

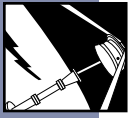

## 7.3-Meter C- and/or Ku-Band



### Antenna Accessories

*Factory Feed System Testing and Documentation*  
*Transmit Waveguide Kits, Cross-Axis Az/EI/Pol*  
*Motorization Kits*  
*Geostationary Indoor Antenna Positioner with*  
*40 Satellite Memory*  
*Inclined Orbit Tracking Indoor Antenna*  
*Positioner (steptrack)*  
*Anti-Icing and Deicing*  
*LNA Support Kits*  
*Ocean Transport Packing*  
*Hub Ventilation Kit*  
*Grounding Kit*  
*Foundation Kit*  
*Lightning Rod Kit*  
*Maintenance Platform and Ladder*  
*Obstruction Warning Light Kit*  
*Cable-Mounting Kit*  
*Major Subsystem Spare Part Kits*  
*Az/EI Vernier Kits*

### Features:

- *High Gain, Excellent Pattern Characteristics*
- *Advanced Gregorian Optics*
- *3-Year Warranty on All Structural Components*
- *Self-Aligning Main Reflector – No Field Alignment*
- *Field Switchable Rx/Tx Combiner, 2-Port C-Band Circular*
- *Rugged Aluminum and Steel – 125 mph (200 kph) Wind Survival*

### Compliances and Type Approvals:

- *INTELSAT F-3, F-2, F-1, G, (IA032A00 & IA032B00)*
- *FCC Regulation 25.209*
- *ITU-R, S.580-5 and S.465-5*
- *Approved for use in the Territory of Russia by the Ministry of Communications of the Russian Federation*

Communications system integrators and designers can bring their systems on line faster, more economically, and with superior performance with Andrew 7.3-meter Earth Station Antennas (ESAs). Excellent for high-density data, voice, communications networks, and broadcast applications, the Andrew 7.3-meter ESA features a uniquely formed dual reflector Gregorian system coupled with close-tolerance manufacturing techniques. This combination provides extremely accurate surface contour, exceptionally high gain, superior efficiency, and closely controlled pattern characteristics.

Our wide selection of Type Approved antennas speeds system deployment. Type Approved Andrew ESAs can be deployed in the field with minimal testing and decreased administrative and approval requirements. Exceptional performance and versatility enables multiple band operation. The 2-port circular Rx/Tx combiners are field switchable from circular to linear polarization.

Andrew ESAs provide maximum durability with minimal maintenance. The hot-dipped galvanized steel ground mount assembly ensures extended product life. Galvanized and stainless steel hardware maximize corrosion resistance. For cost effective system expansion, available modular equipment options include anti-icing equipment and pressurization systems. Microprocessor steptrack control and motorizable mount options are also available.

## 7.3-Meter C- and/or Ku-Band



### Electrical Specifications

Operating Frequency Band			
C-Band Receive	3.400-4.2 GHz		
C-Band Transmit	5.850-6.725 GHz		
Ku-Band Receive	10.7-12.75 GHz		
Gain, with 2-port combiner (dBi, ±0.2 dB)			
Rx Frequency	Rx Gain	Rx Frequency	Rx Gain
3.400 GHz	47.1	5.925 GHz	51.3
3.700 GHz	47.6	6.175 GHz	51.7
4.000 GHz	48.3	6.425 GHz	52.0
4.200 GHz	48.7	6.725 GHz	52.4
10.950 GHz	55.2	-	-
11.950 GHz	56.0	-	-
12.750 GHz	56.5	-	-
Polarization			
C-Band	Linearly- or Circularly-Polarized		
Ku-Band	Linearly-Polarized		
Polarization Discrimination (Linearly-Polarized)			
>35 dB across 1 dB beamwidth	19 - 25 log $\theta$ from 1.8° to 9.2°		
Voltage Axial Ratio, C-Band, circularly-polarized with 4-port combiner <1.06:1 across the 1 dB beamwidth <1.09 and 1.2 with 2-port			
Beamwidth, Mid-band, Degrees	C-Band	Ku-Band	
3 dB Receive (Transmit)	0.66 (0.44)	0.22 (0.18)	
15 dB Receive (Transmit)	1.30 (0.83)	0.39 (0.31)	
Antenna Noise Temperature – under clear sky conditions, at 68°F (20°C), with 2-port linear combiner.			
Elevation	Kelvin (C-Band)	Kelvin (Ku-Band)	
10°	42	48	
30°	31	34	
50°	29	29	
Antenna VSWR, Transmit and Receive			<1.3:1

### G/T Performance (C-Band)

LNA/LNB Noise Temperature	65K	45K	30K
ES73 G/T at 10° EL (dB/K)	28.3	29.4	30.3

Based on a 2-port, linearly-polarized antenna configuration at 4 GHz and at 10° elevation under clear sky conditions.

### G/T Performance (Ku-Band)

LNA/LNB Noise Temperature	165K	125K	90K
ES73 G/T at 10° EL (dB/K)	32.5	33.3	34.2

Based on a 2-port, linearly-polarized antenna configuration at 12 GHz and at 10° elevation under clear sky conditions.

### Uplink EIRP Capability\* (C-Band)

HPA Output (watts)	125	500	3000
Uplink EIRP (dBW)	72.6	78.7	86.4

Based on a 2-port antenna configuration at 6.175 GHz and 0 dB allowance for waveguide (IFL) loss between the HPA and the antenna.

\* Optional extended AZ range of 160° continuous.

### Mechanical Specifications

Feed Type	Dual-Reflector, Gregorian
Reflector Material	Precision-Formed Aluminum
Reflector Segments	16
Mount Type	El over Az, Tripod
Antenna Pointing Range, Coarse/(Continuous)	
Elevation	0-90° (90°)
Azimuth	180° (120°)
Polarization	180° (180°)
Hub/Enclosure Dimensions	
Diameter	52 in (1.32 m)
Depth	48.5 in (1.17 m)
Wind Loading, Survival	
125 mph (200 km/h) in any position of operation	
Wind Loading, Operational	
45 mph (72 km/h), gusting to 65 mph (105 km/h) (motor drives)	
Temperature, Operational	
-40° to 125°F (-40° to 52°C)	
Rain	
4 in (102 mm) per hour	
Solar Radiation	
360 BTU/hr/ft <sup>2</sup> (1135 watts/m <sup>2</sup> )	
Relative Humidity	
100%	
Shock and Vibration	
As encountered by commercial air, rail and truck shipment	
Atmospheric Conditions	
Moderate coastal/industrial areas. Severe conditions require additional protection.	

### Typical Slab Foundation Information

Soil Bearing Capacity	2000 lb/ft <sup>2</sup> (9,764 kg/m <sup>2</sup> )
Reinforcing Steel	1708 lb (807 kg)
Concrete Compressive Strength	3000 lb/in <sup>2</sup> (211 kg/cm <sup>2</sup> )
Foundation Size:	
Length	15.5 ft (4.7 m)
Width	15.5 ft (4.7 m)
Depth	2.0 ft (0.6 m)
Concrete Volume	17.8 yd <sup>3</sup> (13.6 m <sup>3</sup> )

Note: Other typical foundation designs are available.

### Typical Shipping Information

Net Weight	6500 lb (2948 kg)
Gross Shipping Weight	8200 lb (3720 kg)
Shipping Volume	780 ft <sup>3</sup> (22.1 m <sup>3</sup> )
Shipping Container	Standard 20 ft land/sea container

All designs, specifications and availabilities of products and services presented are subject to change without notice.



## 7.6-Meter C-, X-, Ku- or K-Band



### Antenna Accessories

*Factory Feed System Testing and Documentation*  
*Transmit Waveguide Kits, Cross-Axis Az/EI/Pol*  
*Motorization Kits*  
*Geostationary Indoor Antenna Positioner with*  
*40 Satellite Memory*  
*Inclined Orbit Tracking Indoor Antenna*  
*Positioner (steptrack)*  
*Anti-Icing and Deicing*  
*LNA Support Kits*  
*Ocean Transport Packing*  
*Hub Ventilation Kit*  
*Grounding Kit*  
*Foundation Kit*  
*Lightning Rod Kit*  
*Maintenance Platform and Ladder*  
*Obstruction Warning Light Kit*  
*Cable-Mounting Kit*  
*Major Subsystem Spare Part Kits*  
*Az/EI Vernier Kits*

### Features:

- *High Gain, Excellent Pattern Characteristics*
- *Advanced Gregorian Optics*
- *Rugged Aluminum and Steel – 125 mph (200 kph) Wind Survival*
- *No Field Alignment (C-Band)*
- *3-Year Warranty on All Structural Components*

### Compliances:

- *APSTAR*
- *ASIASAT*
- *BRASILSAT*
- *INTELSAT E-3, F-3, D, G*
- *EUTELSAT*
- *ITU-R, S.580-5 and S.465-5*
- *US FCC Regulation 25.209*
- *Approved for use in the Territory of Russia by the Ministry of Communications of the Russian Federation (Reference: Homologation Certificate No OC/I-A -f-1)*

Television broadcasters and telecommunications system operators, integrators, and designers can bring their systems on line faster, more economically, and with superior performance with the Andrew 7.6-meter Earth Station Antenna (ESA). In use worldwide in broadcast applications and high-density data, voice, communications networks, the Andrew 7.6-meter ESA features a computer-optimized dual-reflector Gregorian system and close-tolerance manufacturing techniques. This combination provides extremely accurate surface contour, exceptionally high gain, superior efficiency, and closely controlled pattern characteristics.

Our wide selection of Type Approved antennas speeds system deployment. Type Approved Andrew ESAs can be deployed in the field with minimal testing and decreased administrative and approval requirements. Andrew ESAs provide maximum durability with minimal maintenance. The hot-dipped galvanized steel ground mount assembly ensures extended product life. Galvanized and stainless steel hardware maximize corrosion resistance. For cost effective system expansion, available modular equipment options include anti-icing equipment and pressurization systems. Microprocessor steptrack control and motorizable mount options are also available.

# 7.6-Meter C-, X-, Ku- or K-Band

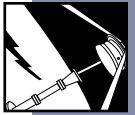

## Electrical Specifications

Operating Frequency Band	
C-Band Receive	3.4-4.2 GHz
C-Band Transmit	5.850-6.725 GHz
X-Band Receive	7.25-7.75 GHz
X-Band Transmit	7.90-8.40 GHz
Ku-Band Receive	10.7-13.25 GHz
Ku-Band Transmit	14.0-14.8 GHz
K-Band Transmit	17.3-18.4 GHz

Gain, with 2-port linear combiner (dBi, ±0.2dB)			
Rx Frequency	Rx Gain	Tx Frequency	Tx Gain
3.400 GHz	47.2	5.850 GHz	52.1
3.625 GHz	47.8	6.175 GHz	52.6
4.000 GHz	48.7	6.425 GHz	52.9
4.200 GHz	49.1	6.725 GHz	53.2
7.250 GHz	54.0	7.90 GHz	54.6
7.500 GHz	54.2	8.15 GHz	54.7
7.750 GHz	54.4	8.40 GHz	54.9
10.700 GHz	56.7	13.75 GHz	58.9
10.950 GHz	57.0	14.00 GHz	59.1
11.950 GHz	57.8	14.25 GHz	59.3
12.750 GHz	58.3	14.50 GHz	59.4
		14.80 GHz	59.6
		17.30 GHz	60.2
		18.40 GHz	60.7

Polarization	
Linearly- or Circularly-Polarized	

Polarization Discrimination (Linearly-Polarized)	
>35 dB across 1 dB beamwidth	19 - 25 log $\theta$ from 1.8° to 9.2°

Voltage Axial Ratio, C-Band, circularly-polarized with 4-port combiner	
<1.06:1 across the 1 dB beamwidth X-Band, <1.20:1 on axis, Tx and Rx	

Beamwidth, Mid-band, Degrees			
	C-Band	Ku-Band	X-Band
3 dB Receive (Transmit)	0.58 (0.39)	0.22 (0.18)	0.33 (0.30)
15 dB Receive (Transmit)	1.18 (0.75)	0.39 (0.31)	0.62 (0.57)

Antenna Noise Temperature – under clear sky conditions, at 68°F (20°C), with 2-port combiner.			
Elevation	Kelvin (C-Band)	Kelvin (X-Band)	Kelvin (K- and Ku-Band)
10°	45	45	55
30°	36	36	41
50°	32	32	36

Antenna VSWR, Transmit and Receive			
			<1.3:1

## G/T Performance (C-Band)

LNA/LNB Noise Temperature	65K	45K	30K
ES76 G/T at 10° EL (dB/K)	28.2	29.0	29.7

Based on a 2-port, linearly-polarized antenna configuration at 4 GHz and at 10° elevation under clear sky conditions.

## G/T Performance (X-Band)

LNA/LNB Noise Temperature	100K	75K	50K
ES76 G/T at 10° EL (dB/K)	32.3	33.1	34.1

Based on a 2-port, circularly-polarized antenna configuration at 7.5 GHz and at 10° elevation under clear sky conditions.

## G/T Performance (Ku-Band)

LNA/LNB Noise Temperature	165K	125K	90K
ES76 G/T at 10° EL (dB/K)	34.4	35.3	36.1

Based on a 2-port, circularly-polarized antenna configuration at 12 GHz and at 10° elevation under clear sky conditions.

## Mechanical Specifications

Feed Type	Dual-Reflector, Gregorian
Reflector Material	Precision-Formed Aluminum
Reflector Segments	8
Mount Type	EI over Az, Tripod

Antenna Pointing Range, Coarse/(Continuous)	
Elevation	0-90° (90°)
Azimuth	180° (120°)
Polarization	180° (180°)

Hub/Enclosure Dimensions	
Diameter	52 in (1.32 m)
Depth	46 in (1.17 m)

Wind Loading, Survival	
125 mph (200 km/h) in any position of operation	

Wind Loading, Operational	
45 mph (72 km/h), gusting to 65 mph (105 km/h) (motor drives)	

Temperature, Operational	
-40° to 125°F (-40° to 52°C)	

Rain	
4 in (102 mm) per hour	

Solar Radiation	
360 BTU/hr/ft <sup>2</sup> (1135 watts/m <sup>2</sup> )	

Relative Humidity	
100%	

Shock and Vibration	
As encountered by commercial air, rail and truck shipment	

Atmospheric Conditions	
Moderate coastal/industrial areas. Severe conditions require additional protection.	

## Slab Foundation Information

Soil Bearing Capacity	2000 lb/ft <sup>2</sup> (9770 kg/m <sup>2</sup> )
Reinforcing Steel	1681 lb (764 kg)
Concrete Compressive Strength	3000 lb/in <sup>2</sup> (211 kg/cm <sup>2</sup> )
Foundation Size:	
Length	19.5 ft (5.94 m)
Width	19.5 ft (5.94 m)
Depth	2.5 ft (0.76 m)
Concrete Volume	35.2 yd <sup>3</sup> (27 m <sup>3</sup> )

Note: Other typical foundation designs are available.

## Typical Shipping Information

Net Weight	6500 lb (2948 kg)
Gross Shipping Weight	8200 lb (3720 kg)
Shipping Volume	780 ft <sup>3</sup> (22.1 m <sup>3</sup> )
Shipping Container	Standard 20 ft land/sea container

All designs, specifications and availabilities of products and services presented are subject to change without notice.

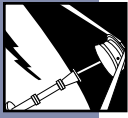

## 9.3-Meter C-Band



### Antenna Accessories

*Factory Feed System Testing and Documentation*  
*Transmit Waveguide Kits, Cross-Axis Az/EI/Pol*  
*Motorization Kits*  
*Geostationary Indoor Antenna Positioner with*  
*40 Satellite Memory*  
*Inclined Orbit Tracking Indoor Antenna*  
*Positioner (Steptrack)*  
*Anti-Icing and Deicing*  
*LNA Support Kits*  
*Ocean Transport Packing*  
*Hub Ventilation Kit*  
*Grounding Kit*  
*Foundation Kit*  
*Lightning Rod Kit*  
*Maintenance Platform and Ladder*  
*Obstruction Warning Light Kit*  
*Cable-Mounting Kit*  
*Major Subsystem Spare Part Kits*  
*Az/EI Vernier Kits*

### Features:

- *High Gain, Excellent Pattern Characteristics*
- *Advanced Gregorian Optics*
- *3-Year Warranty on All Structural Components*
- *Horizon-to-Horizon Coverage with Elevation-over-Azimuth Mount*
- *Rugged Aluminum and Steel – 125 mph (200 kph) Wind Survival in any Position*

### Compliances:

- *APSTAR*
- *ASIASAT*
- *BRASILSAT*
- *INTELSAT B, F-3, F-2, F-1, D-2, G*
- *ITU-R, S.580-5 and S.465-5*
- *FCC Regulation 25.209*
- *Approved for use in the Territory of Russia by the Ministry of Communications of the Russian Federation (Reference: Homologation Certificate No OC/I-A -f-1)*

Now telecommunications and television system operators, integrators and designers can bring their systems on line faster, more economically, and with superior performance with the Andrew 9.3-meter Earth Station Antenna (ESA). In use around the world in broadcast applications and high-density data, voice, communications networks, the Andrew 9.3-meter ESA features a computer-optimized dual reflector Gregorian system coupled with independently adjustable reflector panels and trusses and close-tolerance manufacturing techniques. This combination provides extremely accurate surface contour, exceptionally high gain, superior efficiency, and closely controlled pattern characteristics. Additionally, the elevation-over-azimuth mount enables horizon-to-horizon coverage from any worldwide location.

Our wide selection of Type Approved antennas speeds system deployment. Type Approved Andrew ESAs can be deployed in the field with minimal testing and decreased administrative and approval requirements.

Andrew ESAs provide maximum durability with minimal maintenance. The hot-dipped galvanized steel ground mount assembly ensures extended product life. Galvanized and stainless steel hardware maximizes corrosion resistance.

A variety of options are available for cost effective system expansion, including 2- or 4-port linearly- or circularly-polarized combining networks, programmable control systems, feed rotation systems, maintenance platforms, professionally designed and documented cross-axis waveguide kits, and pressurization systems. Microprocessor and steptrack controls are also available for motorized antennas.



## Electrical Specifications

<b>Operating Frequency Band</b>	
<b>C-Band Receive</b>	3.4-4.2 GHz
<b>C-Band Transmit</b>	5.850-6.725 GHz

<b>9.3m Series, with 2-port linear combiner</b>			
<b>Rx Frequency</b>	<b>Rx Gain</b>	<b>Tx Frequency</b>	<b>Tx Gain</b>
3.400 GHz	49.2	5.850 GHz	53.5
3.625 GHz	49.6	6.175 GHz	53.9
4.000 GHz	50.4	6.425 GHz	54.1
4.200 GHz	50.8	6.725 GHz	54.6

<b>9.3m Series, with 4-port circular combiner</b>			
<b>Rx Frequency</b>	<b>Rx Gain</b>	<b>Tx Frequency</b>	<b>Tx Gain</b>
3.625 GHz	50.0	5.850 GHz	53.1
4.000 GHz	50.9	6.175 GHz	53.5
4.200 GHz	51.3	6.425 GHz	53.8

<b>Polarization</b>	
Linearly- or Circularly-Polarized	
<b>Polarization Discrimination (Linearly-Polarized)</b>	
>35 dB across 1 dB beamwidth	19 - 25 log $\phi$ from 1.8° to 9.2°
<b>Voltage Axial Ratio</b> , C-Band, circularly-polarized with 4-port combiner <1.06:1 across the 1 dB beamwidth <1.09 and 1.2 with 2-port	
<b>Beamwidth, Mid-band, Degrees</b>	<b>C-Band</b>
3 dB Receive (Transmit)	0.51 (0.34)
15 dB Receive (Transmit)	1.00 (0.65)

<b>Antenna Noise Temperature</b> – under clear sky conditions, at 68°F (20°C), with 2-port combiner..	
<b>Elevation</b>	<b>Kelvin</b>
10°	39
30°	29
50°	27

<b>Antenna VSWR, Transmit and Receive</b>	<1.3:1
---	--------

## G/T Performance

<b>LNA/LNB Noise Temperature</b>	65K	45K	30K
<b>ES93 G/T at 10° EL (dB/K)</b>	30.0	30.9	31.8

Based on a 4-port, linearly-polarized antenna configuration at 4 GHz.

## Uplink EIRP Capability

<b>HPA Output (watts)</b>	125	500	3000
<b>Uplink EIRP (dBW)</b>	74.8	79.8	88.6

Based on a 2-port antenna configuration at 6.175 GHz and 0 dB allowance for waveguide (IFL) loss between the HPA and the antenna.

## Mechanical Specifications

<b>Feed Type</b>	Dual-Reflector, Gregorian
<b>Reflector Material</b>	Precision-Formed Aluminum
<b>Reflector Segments</b>	20
<b>Mount Type</b>	EI over Az, Tripod

<b>Antenna Pointing Range, Coarse/(Continuous)</b>	
Elevation	0-90° (90°)
Azimuth	180° (120°)
Polarization	180° (180°)

<b>Hub/Enclosure Dimensions</b>	
Diameter	84 in (2.31 m)
Depth	46 in (1.17 m)

<b>Wind Loading, Survival</b>	
125 mph (200 km/h) in any position of operation	

<b>Wind Loading, Operational</b>	
45 mph (72 km/h), gusting to 65 mph (105 km/h) (motor drives)	

<b>Temperature, Operational</b>	-40° to 125°F (-40° to 52°C)
---------------------------------	------------------------------

<b>Rain</b>	4 in (102 mm) per hour
-------------	------------------------

<b>Solar Radiation</b>	360 BTU/hr/ft <sup>2</sup> (1135 watts/m <sup>2</sup> )
------------------------	---

<b>Relative Humidity</b>	100%
--------------------------	------

<b>Shock and Vibration</b>	As encountered by commercial air, rail and truck shipment
----------------------------	---

<b>Atmospheric Conditions</b>	Moderate coastal/industrial areas. Severe conditions require additional protection.
-------------------------------	---

## Slab Foundation Information

<b>Soil Bearing Capacity</b>	2000 lb/ft <sup>2</sup> (9770 kg/m <sup>2</sup> )
<b>Reinforcing Steel</b>	2946 lb (1339 kg)
<b>Concrete Compressive Strength</b>	3000 lb/in <sup>2</sup> (211 kg/cm <sup>2</sup> )

<b>Foundation Size:</b>	
Length	19.5 ft (5.94 m)
Width	19.5 ft (5.94 m)
Depth	2.5 ft (0.76 m)
Concrete Volume	35.2 yd <sup>3</sup> (27 m <sup>3</sup> )

Note: Other typical foundation designs are available.

## Typical Shipping Information

<b>Net Weight</b>	8000 lb (3629 kg)
<b>Gross Shipping Weight</b>	11,154 lb (5059 kg)
<b>Shipping Volume</b>	1280 ft <sup>3</sup> (36.3 m <sup>3</sup> )
<b>Shipping Container</b>	Standard 40 ft land/sea container

All designs, specifications and availabilities of products and services presented are subject to change without notice.



## ESA Options



### *Additional Options to Complement Your Andrew Earth Station Antenna*

- **Motorization** – Low/Medium, High-Speed or Steptracking Available
- **Local Motor Control Options**
- **Remote Control Options** – Standard and Steptracking Available
- **LNA/LNB Subsystems**
- **Testing and Installation Services**
- **EZM&C Monitor and Control System**

Contact your Andrew account manager for additional information on the options available for your earth station antenna.

# Earth Station Antenna Customer Definition Check List



Project: \_\_\_\_\_ Contact Name(s): \_\_\_\_\_  
 Company Name: \_\_\_\_\_ Street Address: \_\_\_\_\_  
 City: \_\_\_\_\_ State/Province: \_\_\_\_\_ Zip Code: \_\_\_\_\_ Country: \_\_\_\_\_  
 Telephone Number: \_\_\_\_\_ FAX Number: \_\_\_\_\_

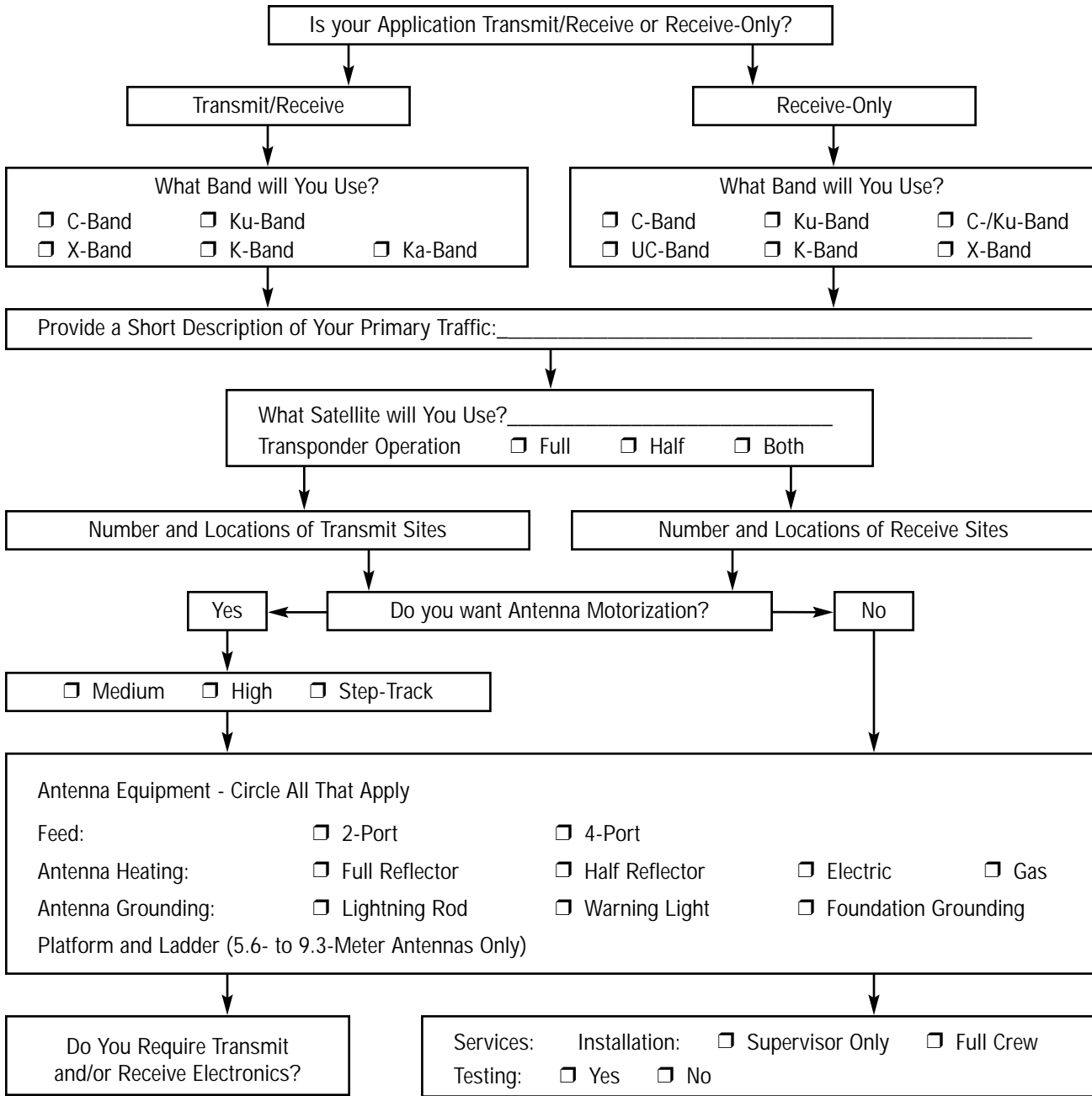

Earth Station Antenna Products and Systems

Use in conjunction with "Customer Definition Checklist" at <http://www.andrew.com>



## 1.2-/1.5-/1.8-/2.4-Meter NewsFlash™ Ku- or K-Band Transportable SNG Antennas



2.4-Meter Transportable SNG Antenna



1.2-Meter NewsFlash™ Transportable SNG Antenna

### Antenna Features

- A Motorized Drive System for a Reliable, Precise, and Smooth Running System
- Stow Height is 24 in (2.4-meter) or 19 in (1.2-meter) for More Overall Clearance for the Vehicle
- A New Antenna Controller Combines Encoders and Remote and Local Controls into a Small, Easy to Operate Package
- 2.4-Meter Antenna Travel is 65° Elevation and  $\pm 175^\circ$  Azimuth. 1.2-/1.5-Meter Antenna Travel is 0 - 90° Elevation and  $\pm 200^\circ$  Azimuth
- An Option for 90° Elevation is Available

### Drive System Features

- Automatic Deploy
- Automatic Stow
- Manual Jog Control
- Variable Speed all Axes including Polarization
- Absolute Elevation Angle (Not Relative to Vehicle)
- Worldwide Operation in both Northern and Southern Hemispheres
- Rack Mount and Handheld User Interfaces with Angular Display
- Full Feature and Basic Handheld Options
- 12Vdc Vehicle System Powered
- Azimuth Correction for Heading Offset
- Full Status, Limit, and Fault Reporting

The new Ku-band SNG antennas from Andrew have been redesigned to be more compact and lighter. This new design results in an antenna whose total assembly weight has decreased. The decrease in weight eases installation and vehicle requirements.

Choose the Andrew advantage for your next antenna. Every antenna system is backed by our 24-hour technical/customer support services and a three-year warranty on all structural components.

# 1.2-/1.5-/1.8-/2.4-Meter NewsFlash™ Ku- or K-Band Transportable SNG Antennas



## Electrical Specifications

Antenna Type	ES12 SNG	ES15 SNG	ES18 SNG	ES24 SNG
Diameter, meters	1.2	1.5	1.8	2.4
<b>Gain, dBi w/2-port combiner – Receive 10.70 - 12.75 GHz</b>				
10.70	42.2	44.2	44.9	47.1
11.35	42.5	44.5	45.3	47.5
11.75	42.8	44.7	45.6	47.9
11.95	42.9	44.8	45.8	48.1
12.35	43.1	45.0	46.0	48.3
12.75	43.2	45.2	46.1	48.5
<b>Gain, dBi w/2-port combiner – Transmit 13.75 - 14.50 GHz</b>				
13.75	43.6	45.5	46.8	49.3
14.125	43.5	45.6	47.0	49.6
14.50	43.6	45.6	47.2	49.7
VSWR, max. Tx/Rx	1.3:1	1.3:1	1.3:1	1.3:1
<b>Cross Polarization Discrimination, dB</b>				
On axis, Tx/Rx	<-35/-35	<-35/-35	<-35/-35	<-35/-35
@1dB, Tx/Rx	<-35/-25	<-35/-25	<-35/-35	<-35/-35
<b>3 dB Beamwidth, Degrees</b>				
14.125 GHz	1.25	1.00	0.81	0.61
10.70 GHz	1.34	1.07	0.96	0.72
<b>15 dB Beamwidth, Degrees</b>				
14.125 GHz	2.60	2.09	1.77	1.33
10.70 GHz	2.77	2.22	1.89	1.42
<b>Noise Temp., (@10.95 GHz) - w/2-port combiner</b>				
Elevation	Kelvin	Kelvin	Kelvin	Kelvin
10°	51	51	49	48
30°	39	39	38	35
50°	37	37	36	33
<b>Tx Power, max</b>				
	1.2-/1.5-meter		1.8-/2.4-meter	
2-Port Network	1kW		2kW	
4-Port Network	N/A		1kW	
<b>Feed Interface Flanges, Receive/Transmit</b>				
			WR75	
<b>Isolation, minimum, Tx into Rx, dB</b>				
	35 (2-Port)		85 (4-Port)	
<b>Power Density Data – 2.4-meter</b>				
Projected Width of Reflector			94 in	
Area of Feed Horn Aperture			5 in <sup>2</sup>	
Focal Length			55 in	
<b>Power Density Data – 1.8-meter</b>				
Projected Width of Reflector			71 in	
Area of Feed Horn Aperture			3 in <sup>2</sup>	
Focal Length			42 in	
<b>Power Density Data – 1.5-meter</b>				
Projected Width of Reflector			64 in	
Area of Feed Horn Aperture			5 in <sup>2</sup>	
Focal Length			54 in	
<b>Power Density Data – 1.2-meter</b>				
Projected Width of Reflector			51 in	
Area of Feed Horn Aperture			5 in <sup>2</sup>	
Focal Length			43 in	

## Electrical Specifications

Antenna Type	ES12 SNG	ES15 SNG	ES18 SNG	ES24 SNG
Diameter, meters	1.2	1.5	1.8	2.4
Feed Type	Prime Focus, Offset		Prime Focus, Offset	
<b>Survival Wind Rating,</b>				
mph (kph) Any Position	80 (129)	80 (129)	65 (105)	65 (105)
Radial Ice, in (mm)	1/2 (13) @60 mph			
<b>Operational Wind Rating, mph (kph)</b>				
	30 gusting to 45 (48 gusting to 72)			
<b>Travel Range - Continuous</b>				
Elevation, degrees	0 - 90	0 - 90	0 - 65	0 - 65
Azimuth, degrees	±200	±200	180, 270, 350	
Net Weight, lb (kg)	150 (68)	185 (84)	690 (313)	690 (313)
<b>Travel Rate</b>				
Elevation, degrees (max/min)	2.0/0.1		1.0/0.25	
Azimuth, degrees (max/min)	2.0/0.1		1.0/0.25	
<b>Maximum Stow Height, in (mm)</b>				
	19 (483)		24 (607)	
<b>Environmental</b>				
Survival Temperature, F (C)	-40 to +140 (-40 to +60)			
Operational Temperature, F (C)	-20 to +122 (-29 to 50)			
Rainfall	4 in/hr (102 mm/hr)			
Relative Humidity	100%			
Solar Radiation, BTU/hr/ft <sup>2</sup>	360 (1135 watts/m <sup>2</sup> )			
Corrosion	Indicative of coastal or industrial areas			
<b>Reflector Construction</b>				
	Formed Aluminum			
<b>Mount Construction</b>				
	Aluminum			
<b>Feed Arm (2.4-Meter Only)</b>				
Capacity	180 lb			
Area	29.5 in x 36.5 in x 12 in High (8.3 ft <sup>3</sup> )			
<b>Electrical Requirements</b>				
Local Unit Voltage	12 Vdc, from vehicle			

All designs, specifications and availabilities of products and services presented are subject to change without notice.



## 3.7-/4.5-Meter C-, X- or Ku-Band Transportable Antennas



3.7-Meter Transportable Antenna



4.5-Meter Transportable Antenna

### Antenna Accessories

*Factory Feed System Testing and Documentation  
Transmit Waveguide Kits, Cross-Axis Az/EI/Pol  
LNA Support Kits*

### Features

- *Exceptional Electrical Performance*
- *Available in Three Modular Types*
- *Outstanding Wind Survival*
- *Complete Line of Control Options*
- *Versions Supplied with 20,000 Pound Jack for EI Axis*

Now system designers and operators can benefit from an exceptional combination of high gain, excellent pattern performance, and extensive versatility from the 2- and 4-port feed system designs in the 3.7-/4.5-meter C-, X-, and Ku-Band transportable earth station antennas from Andrew Corporation. The antennas' aluminum trifold reflector panels are cut from a single-piece precision spinning. Panel design and manufacture provide excellent thermal expansion characteristics and ensures the extremely accurate surface contour.

The antennas meet or exceed ASIAT, EUTELSAT, PANAMSAT, APSTAR, BRAZILSAT and INTELSAT requirements. They also meet or exceed US FCC regulation 25-209, for mandatory pattern requirements for 2° satellite spacing based on off-satellite measurements. This applies to the 3.7-meter (Ku-band) and 4.5-meter (C- or Ku-Band). The antennas meet or exceed ITU-R S.580-5 and S.465-5 recommendations for pattern performance for 2° satellite spacing.

Three modular types are available: antenna only, antenna with manual/motorizable elevation-over-azimuth positioner, and antenna with manual/motorizable positioner and heavy duty tandem axle trailer.

The unique Trifold® antenna design enables one-person deployment in less than 30 minutes. A large range of adjustment provides non-critical positioner/trailer orientation and the ability to view geostationary satellites, horizon-to-horizon, from any location world wide. The aluminum back structure and hot-dipped galvanized steel positioner maintain pointing accuracy and ensure durability and reliability.

## 3.7-/4.5-Meter C-, X- or Ku-Band Transportable Antennas

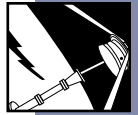

### Electrical Specifications – 3.7m

Operating Frequency Band			
C-Band Receive	3.625-4.2 GHz		
C-Band Transmit	5.850-6.425 GHz		
X-Band Receive	7.25-7.75 GHz		
X-Band Transmit	7.90-8.40 GHz		
Ku-Band Receive	10.95-12.75 GHz		
Ku-Band Transmit	14.0-14.8 GHz		
K-Band Receive	10.95-12.75 GHz		
K-Band Transmit	17.3-18.4 GHz		
Gain, with 2-port combiner (dBi, ±0.2 dB)			
Rx Frequency	Rx Gain	Tx Frequency	Tx Gain
3.625 GHz	41.0	5.850 GHz	45.6
4.000 GHz	42.5	6.175 GHz	46.1
4.200 GHz	43.0	6.425 GHz	46.3
7.250 GHz	47.7	7.90 GHz	48.2
7.500 GHz	47.9	8.15 GHz	48.4
7.750 GHz	48.1	8.40 GHz	48.6
10.950 GHz	50.9	14.00 GHz	52.7
11.950 GHz	51.6	14.25 GHz	52.8
12.750 GHz	52.1	14.50 GHz	53.0
		17.3 GHz	54.6
		18.4 GHz	55.0
Polarization Discrimination (Linearly-Polarized)			
C-/Ku-Band	>35 dB on axis	Ku >35 within 1 dB contour	
Voltage Axial Ratio, circularly-polarized with 2-port combiner			
C-Band, <1.09:1 on-axis, Tx	<1.20:1 on-axis, Rx		
X-Band, <1.20:1 on-axis, Tx	<1.20:1 on-axis, Rx		
Beamwidth, Mid-band, Degrees			
	C-Band	X-Band	K- and Ku-Band
3 dB Receive (Transmit)	1.20 (0.80)	0.65 (0.60)	0.42 (0.36)
15 dB Receive (Transmit)	2.00 (1.40)	1.19 (1.09)	0.85 (0.69)
Antenna Noise Temperature – under clear sky conditions, at 68°F (20°C), at the circular waveguide flange of the feed.			
Elevation	Kelvin (C-Band)	Kelvin (X-Band)	Kelvin (K- and Ku-Band)
10°	36	39	39
30°	23	27	26
50°	21	24	24
Antenna VSWR, Transmit and Receive <1.3:1			

### Mechanical Specifications – 3.7m and 4.5m

Feed Type	
3.7 m	Dual-Reflector
4.5 m	Prime Focus
Reflector Material	
Precision-Formed Aluminum	
Reflector Segments	
3-Pieces, Hinged Transportable	
Mount Type, when applicable	
El over AZ, Positioner	
Antenna Pointing Range, Coarse/(Continuous)	
Elevation	5-90° (85°)
Azimuth	330° (330°)
Polarization	360° (90°)
Wind Loading, Survival	
125 mph (200km/h) in stow position, 65 mph (105 km/h) gusting to 80 mph (125 km/h) in any position of operation with proper anchoring	
Wind Loading, Operational (motor drives)	
45 mph (72 km/h), gusting to 65 mph (105 km/h)	
Trailer Size:	
Length	289 in (7.34 m)
Width	96 in (2.44 m)

All designs, specifications and availabilities of products and services presented are subject to change without notice.

### Electrical Specifications – 4.5m

Operating Frequency Band			
C-Band Receive	3.625-4.2 GHz		
C-Band Transmit	5.850-6.425 GHz		
X-Band Receive	7.25-7.75 GHz		
X-Band Transmit	7.90-8.40 GHz		
Ku-Band Receive	10.95-12.75 GHz		
Ku-Band Transmit	14.0-14.8 GHz		
Gain, with 2 port combiner (dBi, ±0.2dB)			
Rx Frequency	Rx Gain	Tx Frequency	Tx Gain
3.625 GHz	43.0	5.925 GHz	46.2
4.000 GHz	44.0	6.175 GHz	46.7
4.200 GHz	44.4	6.425 GHz	47.0
7.250 GHz	48.4	7.90 GHz	49.2
7.500 GHz	48.7	8.15 GHz	49.5
7.750 GHz	49.0	8.40 GHz	49.8
10.950 GHz	51.6	14.00 GHz	53.4
11.950 GHz	52.4	14.25 GHz	53.6
12.750 GHz	52.9	14.50 GHz	53.7
		14.80 GHz	53.8
Polarization Discrimination (Linearly Polarized)			
C-/Ku-Band	>35 dB on axis		
Voltage Axial Ratio, circularly-polarized with 2-port combiner			
C-Band, <1.09:1 on axis, Tx	<1.20:1 on axis, Rx		
X-Band, <1.20:1 on axis, Tx	<1.20:1 on axis, Rx		
Beamwidth, Mid-band, Degrees			
	C-Band	X-Band	Ku-Band
3 dB Receive (Transmit)	1.22 (0.85)	0.66 (0.61)	0.41 (0.33)
15 dB Receive (Transmit)	2.47 (1.90)	1.40 (1.29)	0.86 (0.69)
Antenna Noise Temperature – under clear sky conditions, at 68°F (20°C), at the circular waveguide flange of the feed.			
Elevation	Kelvin (C-Band)	Kelvin (X-Band)	Kelvin (Ku-Band)
10°	32	45	45
30°	20	34	33
50°	16	29	30
Antenna VSWR, Transmit and Receive <1.3:1			

Height, with Trifold® Antenna	
3.7 m	112.1 in (2.85 m), with subreflector/supports 102.1 in (2.59 m), without subreflector/supports
4.5 m	118 in (3.0 m) with feed support 108 in (2.75 m) without feed support
Weight, with Trifold® Antenna	
3.7 m	7200 lb (3266 kg)
4.5 m	7600 lb (3447 kg)
Trailer Wheels	
4, with 1 spare	
Tandem Axle Assembly Capacity	
12,000 lb (5455 kg) tandem with axle with 4 in (102 mm) drop	
Wheel Size	
14.5 in (368 mm)	
Tires	
G78 x 15 Nylon Bias, 8 ply, 8 x 14.5LT	
Trailer Hitch Interface	
2.312 in ball hitch (standard) Pintel hook is available as special order	
Trailer Tongue Weight	
650 lb (295 kg) nominal	
Outrigger Jacks	
4, each with 7000 lb (3282 kg) capacity	
Front Leveling Jack	
5000 lb (2273 kg) capacity	
12 Vdc Electrical Connector	
6-way, includes both male and female	



## VALULink™ II Ku-Band Uplink System

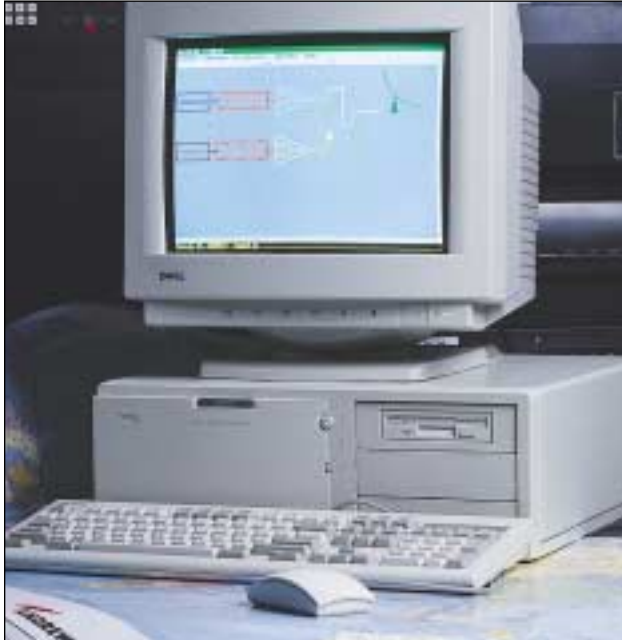

### Features:

- *Varying Power Levels to Support Low Rate Data or Analog Video*
- *Single Thread and Redundant Configurations*
- *Computer Control Supplied in Base System*
- *Analog and/or Digital Video Transmission Equipment*
- *Full Installation and Training Support*
- *Low Cost Digital Ready Video Uplink/Downlink System*
- *High Video/Audio Performance*
- *Remote Controllable*
- *Available With a Number of Configuration Options*
- *Low Cost*
- *For 3.7-, 4.9-, 5.6- and 7.6-Meter Earth Station Antennas*

The basic VALULink™ II system includes the antenna and 2-port T/R feed, 100 feet of IFL cabling, hub-mounted 75 watt TWTA and upconverter, LNB and a PC-based monitor and control (M&C) system. A video modulator and video receiver are available as optional equipment.

The VALULink™ II antenna can be an Andrew 7-meter, 5-meter, 4-meter or 3-meter Ku-band antenna with a hub for mounting the electronics. The 3.7-meter basic configuration provides a saturated EIRP of 70.5 dBw. The system is fully-compliant with FCC rules and includes the required Automatic Transmitter Identification System (ATIS). Redundancy options are available to configure your VALULink™ II to your exact requirements.



## Basic Configuration with Dual-Polarity Switching Option

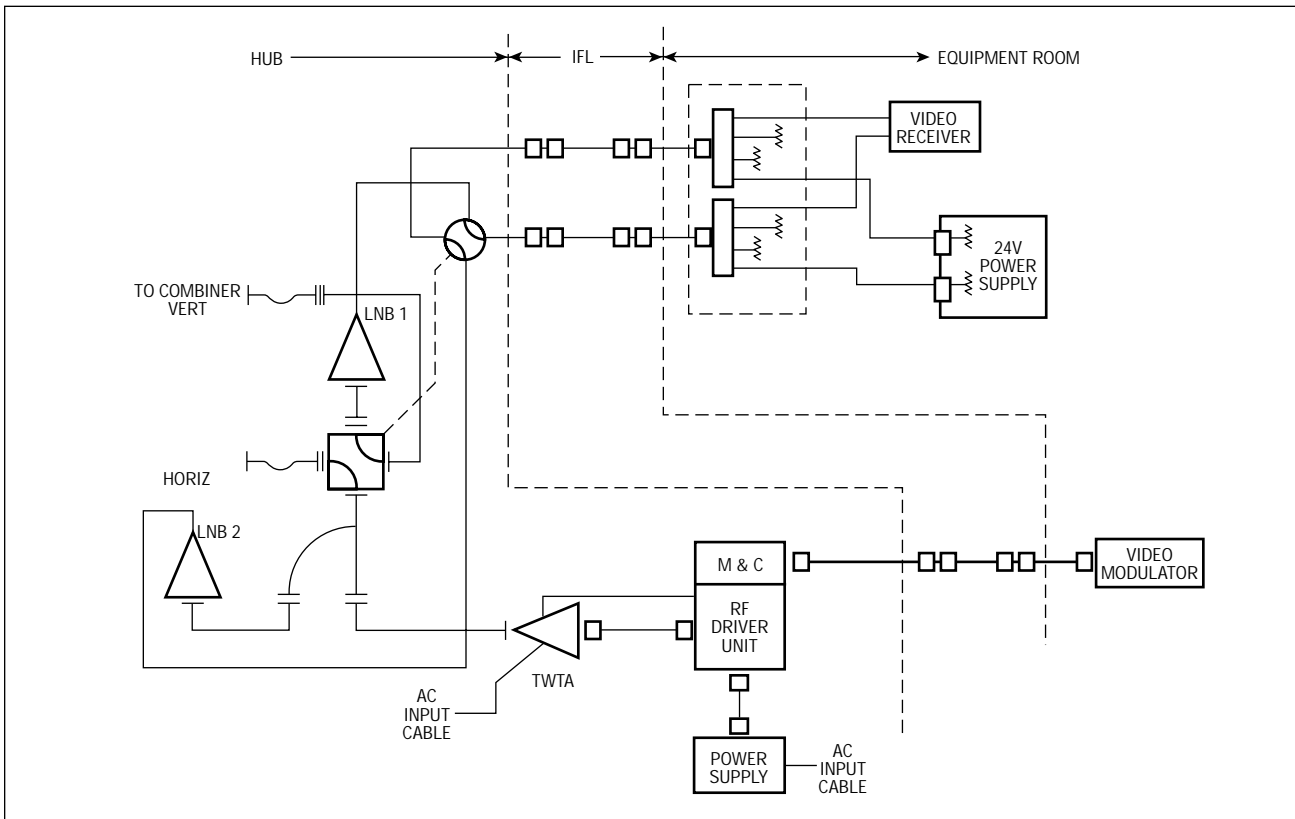

## Ku-Band Receive-Only Performance 3.7M to 4.6M

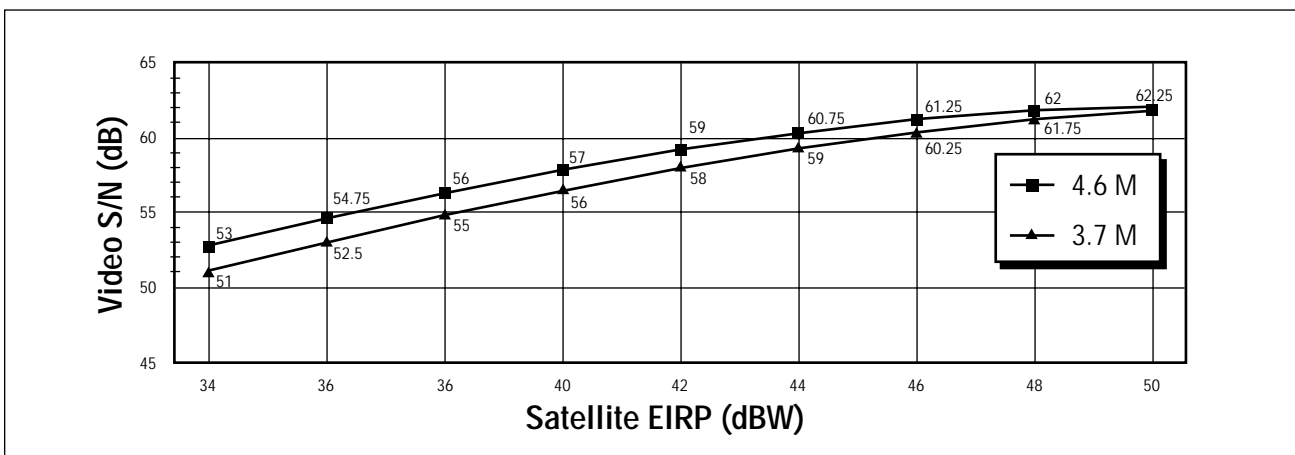

Note: This data is typical for full transponder NTSC operation. Error is typically less than 5%.



**System Program Management.** Each customer order is assigned a program manager to take full control of the project execution. The program manager is the single point of contact, providing unified project implementation. The program manager ensures that the correct equipment is ordered, tested and integrated as required so the system when shipped works the first time, every time.

**System Design Engineering.** Engineering services available for each system project extend from feasibility studies and preliminary conceptual design to final acceptance and performance verification testing.

System design is a direct result of customer requirements, signal quality parameters, regulations, operating frequency band and space segment performance.

**System Documentation.** Each system is documented so that installation, implementation and maintenance are a

simple process. Documentation may include assembly, installation drawings, as-built drawings and equipment operation and maintenance manuals.

**System Installation.** Andrew provides qualified installers who are competent and knowledgeable about all types of installation requirements. Whether it is ground-mount, rooftop or any nonstandard installation, an Andrew crew performs the installation efficiently, in a minimum amount of time. This saves money and allows you to be on-the-air in record time. Andrew can also provide an installation supervisor to assist your crew in the antenna erection.

**System Testing.** The time tested Andrew method of ESA and electronics testing assures that any regulatory requirement, INTELSAT, EUTELSAT, PANAMSAT, U.S. FCC, etc. are met with minimum inconvenience.

## Andrew Earth Station Antenna Turnkey System Capabilities

### Uplinks

- Modulators
- Upconverters
- High Power Amplifiers
- Custom Designed Switching and Combining Networks

### Downlinks

- LNAs/LNBs
- Downconverters
- Demodulators/Receivers
- Signal Distribution

### Packaged Systems

- VALULink™
- GoStation™

### Site

- Standard and Customized Redundance Schemes
- Individually Designed Monitor and Control Solutions
- Turnkey Shelter Installations
- Power Distribution
- UPS Systems

### Services

- Complete Turnkey Design
- Factory Integration and Test
- Program Management
- Site Installation
- Field Test and Commissioning
- Traffic Analysis and Network Design
- Assistance with Link Analysis
- Assistance with Space Segment and Licensing



## ComTier™ \* Satellite Network Products



### **System Solutions for:**

- *Internet-Based Virtual Private Networks (I-VPNs) or I-VPN Overlay*
- *Two-Way Digital Video Broadcast Networks*
- *Interactive Networks*
- *Corporate/Government Enterprise Networks*
- *National/International Telephony/Data Networks*
- *Restoral/Emergency Service/Diversity Networks*

### **Freedom Family of VSAT Network Products**

ComTier has developed several new VSAT systems that use its superior Time Division Multiple Access (TDMA) modem technology to facilitate the deployment and operation of broadband communication satellite networks at a lower total cost of ownership. ComTier's family of VSAT products is called Freedom because of its flexible and scaleable architecture, and its advanced features, which liberate the user from having to accept the performance of traditional VSAT systems. Instead, Freedom VSAT networks provide a whole new array of advanced features that elevate its performance over competitive solutions that are available today.

\* An affiliate of Andrew Corporation

### **Primary Network Products:**

- *FreedomIP™ VSAT*
- *Digital Video Broadcast FreedomIP™ VSAT*

In addition to the two primary network products, there is also the Freedom NMS, which offers a full set of Network Management System features for networks composed of these two products.

### **Advanced Technology**

All Freedom VSAT systems use symbol synchronous Time Division Multiple Access (TDMA) to provide an extremely high burst and frame efficiency—up to 20% better than competitive products. They include an advanced Continuous Phase, Frequency Shift Keyed (CPFSK) modem that enables the use of power amplifiers one half the size of other VSAT systems, greatly reducing system costs. They include advanced bandwidth on demand algorithms to achieve more users per carrier and hence a lower cost per user. These Freedom product lines use existing C-band, Ku-band and Ka-band satellites to provide broadband networking anywhere in the world. This advanced technology provides the user with a lower total cost of ownership.

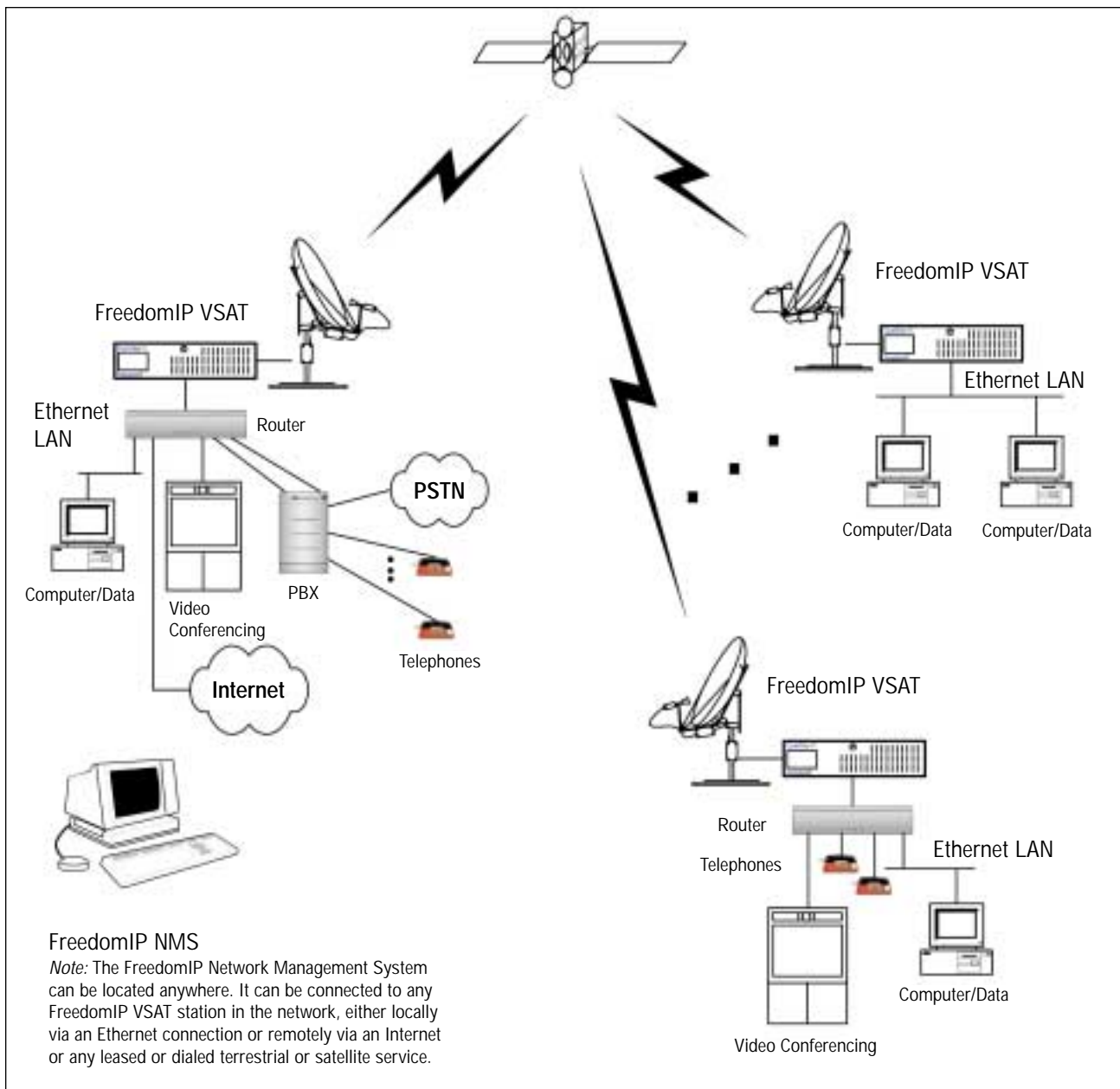

FreedomIP™ (Internet Protocol) VSAT provides a Wide Area Network (WAN) Internet and Intranet access solution based on the IP protocol suite. It is designed to effectively serve two-way Internet Services (ISPs), Intranet/Internet applications, including corporate networks (see above), e-commerce, tele-medicine, financial transactions, SCADA, etc.

FreedomIP™ VSAT can be configured to support Mesh, Star, Broadcast network topologies or any combination as needed to best serve the customer's traffic. Because of its advanced technology, FreedomIP VSAT outperforms conventional VSATs by providing integrated data, video and voice services using less satellite bandwidth. FreedomIP VSAT also uses advanced Bandwidth On Demand (BOD) algorithms to support more users per carrier.

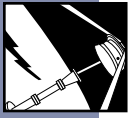

## FreedomIP™ VSAT



### Features:

- Transmission Bit Rates of 235 kbps to 3,750 kbps
- Supports all Standard IP Applications
- Bandwidth On Demand (BOD)
- Single- and Multiple-Carrier Operation
- Lower Total Cost of Ownership

A FreedomIP™ VSAT system consists of two primary assemblies: Indoor Unit (IDU) and Outdoor Unit (ODU). The IDU consists of a Windows NT based server that hosts the FreedomIP User Terminal Modem, Ethernet interface and system software. The ODU consists of a very small aperture antenna and RF transceiver (e.g., 0.9-m to 2.4-meter antennas and 1 watt to 16 watt power amplifiers for Ku-band, and 2.4-meter to 4.6-meter antennas and 5 watt to 20 watt power amplifiers for C-band).

### DVB FreedomIP™ VSAT

The DVB FreedomIP VSAT uses a broadcast standard that has gained widespread acceptability, called Digital Video Broadcast (DVB). In Europe, for example, DVB is an ETSI standard for digital TV broadcasting based on MPEG-2 compression for satellite, cable and microwave. Its purpose is to provide wide bandwidth video and Internet data to many remote users.

The ComTier™ DVB FreedomIP VSAT offers an integrated solution for serving these new two-way DVB applications. It uses standard wide bandwidth DVB outward broadcast channels integrated with its advanced Time Division Multiple Access (TDMA) system, FreedomIP, that operates via one or more inward channels.

### DVB FreedomIP™ Features:

- Outward Information Rates up to 45 Mbps
- Two-Way, Wide Bandwidth Interactive System
- Supports all Standard IP Applications
- Outward Video Channels using Standard Digital Video Broadcast/MPEG-2 Format
- Inward Channel using Multiple Carrier Bandwidth-on-Demand Time Division Multiple Access
- Inward Information Rates within the Range of 200 kbps to 3 Mbps



Some of the typical new broadcasting and interactive multimedia applications that are served by the two-way DVB FreedomIP network solution are:

Data Request/Delivery	E-Commerce	Distance Collaboration
Television Broadcasts	Pay-per-view Television	Distance Learning
On-line Internet Services	Home Shopping	Tele-Medicine
Drag-and-Drop File Transfers	Home Banking	Two-Way Paging
Interconnect of LANs	Direct Market Transactions	Net Meetings
E-mail		Video Conferences

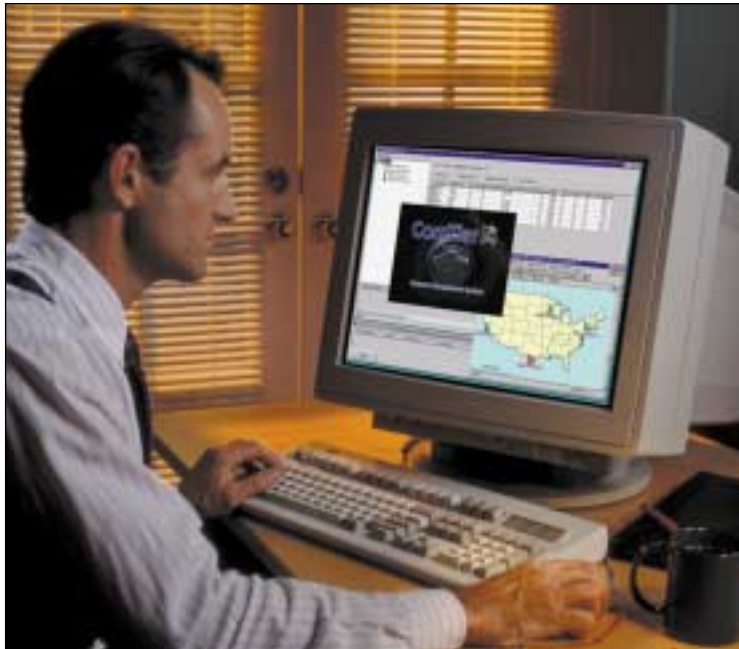

### Freedom NMS

The Freedom Network Management System (NMS) will support all types of Freedom network system solutions. The Freedom NMS is an integrated hardware/software package that runs on a Windows NT platform and allows the service desk operator to control, monitor, diagnose and operate the entire Freedom VSAT network from one (or more) convenient locations. The Freedom NMS components include the desktop computer with software and optional printer.

The advanced Freedom family architecture allows the Freedom NMS to be located anywhere. The Freedom NMS may be connected directly to any FreedomIP VSAT node or it can be remoted via a dialup modem, Internet connection, etc. It is important to note, that the operation of the network is not dependent on the Freedom NMS; i.e., the network will operate even when the Freedom NMS is disconnected. Therefore, there is no single-point of failure in the Freedom VSAT network architecture.